

The Ontic Probability Interpretation of Quantum Theory – Part III

Schrödinger’s Cat and the ‘Basis’ and ‘Measurement’ Pseudo-Problems

Felix Alba-Juez

Copyright © 2020-2024 Felix Alba-Juez¹

Felix Alba-Juez, Publisher - Saint George, Utah (USA) - <https://felixalbajuez.com>

Original Date: April 4, 2021 - Last Revision: September 3, 2024

ABSTRACT

Most of us are either philosophically naïve scientists or scientifically naïve philosophers, so we misjudged Schrödinger’s “very burlesque” portrait of Quantum Theory (QT) as a profound conundrum. The clear signs of a strawman argument were ignored. The Ontic Probability Interpretation (TOPI) is a metatheory: a theory about the meaning of QT. Ironically, equating Reality with Actuality cannot explain actual data, justifying the century-long philosophical struggle. The actual is real but not everything real is actual. The ontic character of the Probable has been elusive for so long because it cannot be grasped directly from experiment; it can only be inferred from physical setups that do not morph it into the Actual. In this Part III, Born’s Rule and the quantum formalism for the microworld are intuitively surmised from instances in our macroworld. The posited reality of the quanton’s probable states and properties is probed and proved. After almost a century, TOPI aims at setting the record straight: the so-called ‘Basis’ and ‘Measurement’ problems are ill-advised. About the first, all bases are legitimate regardless of state and milieu. As for the second, its premise is false: there is no need for a physical ‘collapse’ process that would convert many states into a single state. Under TOPI, a more sensible variant of the ‘measurement problem’ can be reformulated in non-anthropocentric terms as a real problem. Yet, as such, it is not part of QT per se and will be tackled in future papers. As for the mythical cat, the ontic state of a radioactive nucleus is not pure, so its evolution is not governed by Schrödinger’s equation – let alone the rest of his “hellish machine”. Einstein was right: “The Lord is subtle but not malicious”. However, ‘The Lord’ turned out to be much subtler than what Einstein and Schrödinger could have ever accepted. Part IV introduces QR/TOPI: a new theory that solves the century-old problem of integrating Special Relativity with Quantum Theory [1].

¹ This material is distributed under the Creative Commons Attribution License CC BY-NC-SA 4.0, which allows for unrestricted non-commercial use and distribution, provided Parts I, II, III, IV, and future works are adequately cited.

List of Acronyms

QT	Quantum Theory	TOPI	The Ontic Probability Interpretation
EPR	Einstein/Podolsky/Rosen Paper	EPRB	EPR-Bohm Gedankenexperiment
RT	Special Relativity Theory	PD	Probability Distribution
SD	Standard Deviation of a PD	PI	Physical Interaction
GI	Gauge Interaction	TM	True Measurement
R-Time	Time as conceived in RT	QR-Time	Time to be conceived in Part IV
MB	Milieu Basis	QEI	Quanton Emission Interaction
PDI	Pure-Detection Interaction	PTI	Pure-Transformation Interaction
PEI	Pure-Entanglement Interaction	ITI	Intrinsic Tele-Interaction

Introduction

Soon after the **EPR** paper was published, Einstein and Schrödinger had copious epistolary interaction [2] [3] [4] [5]. Many years before, Einstein had conceived a keg of unstable gunpowder that could spontaneously explode – alleging the inadequacy of **QT** because (so he thought) it described the reality of the gunpowder state as a fictitious superposition of contradictory ‘exploded’ and ‘not exploded’ states. So inspired, by the end of 1935 [6], Schrödinger wrote:

SCHR1: *It is also possible to construct very burlesque cases. Imagine a cat locked up in a room of steel together with the following hellish machine (which has to be secured from direct attack by the cat): A tiny amount of radioactive material is placed inside a Geiger counter, so tiny that during one hour perhaps one of its atoms decays, but equally likely none. If it does decay then the counter is triggered and activates, via a relay, a little hammer which breaks a container of prussic acid. After this system has been left alone for one hour, one can say that the cat is still alive provided no atom has decayed in the meantime. The first decay of an atom would have poisoned the cat. In terms of the ψ -function of the entire system this is expressed as a mixture of a living and a dead cat.*

Despite the ‘very burlesque’ and ‘room of steel’ qualifiers, and the grossly misleading last sentence, the above excerpt triggered a pseudo-philosophical conundrum that has lamentably lasted till today. The uncertain fate of this imaginary cat “expressed as a mixture of a living and a dead cat” seems to mysteriously morph into a definite happy or regrettable outcome, epitomizing the so-called ‘Measurement Problem’ and wrongly inspiring the idiom ‘cat states’ for ‘entangled states’. In addition, it has become the frivolous benchmark applied to any interpretation of **QT**. As for the related so-called ‘Basis Problem’, it is rooted in the belief that the infinitude of bases -in terms of which **QT** allows the quanton’s state to be depicted- are ‘incompatible’; that we are compelled to choose one ‘preferred’ basis for each experimental situation (context) and, ergo, that all those representations cannot describe a single physical reality.

Schrödinger also identified *entanglement* as the “characteristic trait of quantum mechanics”, defended **EPR**’s flawed conclusions [4] [5] [7], and went further by hinting that -beyond being **incomplete**- there were serious faults in the very foundation of **QT** [8] [6] [9]. He scorned those “repugnant conclusions”:

SCHR2: *It is suggested that these conclusions, unavoidable within the present theory but repugnant to some physicists including the author, are caused by applying non-relativistic quantum mechanics beyond its legitimate range [9].*

Schrödinger seemed to sensibly imply that macro-entities were beyond QT's legitimate range. But, even as late as 1952, he stated that humans were "not experimenting with single particles any more than we can raise ichthyosauria in the zoo", suggesting that QT was not applicable to individual micro-objects either so that, applying it, "invariably entails ridiculous consequences" [10]. Like Einstein, he viewed *probability* as exclusively *epistemic* (like in Statistical Mechanics).

Most of us are either philosophically naïve scientists or scientifically naïve philosophers and mistook Schrödinger's caricature of QT as a profound enigma. In my opinion, he derisively conceived his iconic thought experiment in the macroworld for maximum impact with a message primarily directed to the microworld. The clear signs of a strawman argument went unnoticed. Remarkably, almost a century later, the 'measurement problem' is still considered unsolved. In 2013, Antoine Suarez asserted that "Quantum physics has still to solve for instance the so-called measurement problem (Schrödinger cat paradox)" [11].

TOPI aims at setting the record straight: the so-called 'Basis' and 'Measurement' problems, as widely stated in the literature, are ill-advised, viz pseudo-problems. However, we will see that, as stated by Gisin [12] and treated by Drossel and Ellis [13] [14], their 'measurement problem' can be reformulated in non-anthropocentric terms, becoming a valid, important, and fascinating challenge.

1. Classical Physics vis à vis QT/TOPI

From the very beginning of our scientific endeavor, we assumed that those relevant physical properties that manifest with the state of a system had *definite* values representable by real numbers, and that they could be -in principle- accurately measured with infinite precision. Were the actual precision not good enough, a better technique and/or instrument could be developed to improve it. If having accurate-enough values for those properties at a given time, our predictions at later times were not good enough, a better theory could be developed to improve them by reconsidering unrealistic hypotheses, including ignored cause-effect relations, adding neglected interactions with the system's exterior, admitting the occurrence of events first thought to be improbable, etc. Whether to predict the system's evolution or to experimentally confirm those predictions, *measurement* was and is crucial in Science. In our TOPI jargon [4] [5], a tenet of Classical Physics was that every GI (Gauge Interaction), regardless of the state of a system, could be improved and refined until it became a TM (True Measurement).

Heisenberg, determined in 1925 to devise a purely phenomenological theory of the atom, declared that the electron's position, speed, and orbit were *unobservable* and therefore they would play no role in his theory. Instead, radiation's frequency, intensity, and polarization were declared *observables* because they could be accurately measured by spectroscopic techniques. He also avowed the atom's energy level as *observable*, despite being *indirectly* inferred, and radiation's phase as *unobservable*, despite its significant role in his theory. But all observations are *inferential*: nobody doubts the reality of UV light – despite its being theoretically inferred from its effects. Likewise, in a Wilson chamber, we see the aligned water droplets and *interpret* them as produced by a single elementary 'particle' that hits larger particles along its path, inducing condensation of supersaturated vapor. Pithily: no theory with which to *infer*, no physical magnitude to *observe*.

Though cursorily ignored, there are innumerable attributes of macro-objects which are *not intrinsic* to them but to the relation with their milieus. In fact, all attributes which are relative to the spacetime reference frame are necessarily non-innate but *extrinsic* properties of a physical object. Examples are *position, velocity, length, mass, kinetic energy, potential energy, time interval*, etc. All these attributes have an *intrinsic* component (e.g. ‘proper mass’, ‘proper length’, ‘proper time’) and an *extrinsic* part due to the object’s interaction with its *milieu* (e.g. gravitational and/or electromagnetic potentials) or simply due to the reference frame. Likewise, in an inertial frame for which a wave source is in repose, *frequency* is *intrinsic* to the wave, while *velocity* and *wavelength* are *extrinsic*, i.e. a joint property of wave and medium. This *extrinsic* character of some physical properties has nothing to do with the observer’s *subjectivity*: it is an *objective* fact ensuing from the interactional nature of those properties, the meaning of ‘reference frame’, and from how the external world is – all three combined.

Classical Physics had assumed that the variability associated with repeatedly *measuring* a physical attribute under the same conditions was inherent in the measurement process itself and had nothing to do with the attribute – which had to have only one numerical *value*. The notion of a *random variable* was thus conceived to represent such inherent variability of data collection. It was natural to introduce the anthropic term *uncertainty* of the *actual value* for the physical magnitude as well as *precision* and *accuracy* for the measurement. Had the variability been due to a subtle deeply embedded intrinsic variability of the physical attribute, there was no way to know it. *Determinism* was hence a hypothesis believed to be amply confirmed – until new experimental evidence to the contrary accumulated, giving birth to **QT**. Even so, the belief was so strong that the emerging theoretical scaffold -needed to accommodate the new evidence- was persistently conceived and explained (still is) with the anthropic process of *measurement* (and even *cognition!*) – instead of around a Reality being progressively unveiled [15] [16] [17] [18] [19] [3].

Despite Aristotle’s *Metaphysics* considering *actuality* and *potentiality* as different forms of Being (though he ultimately gave supremacy to *actuality*), in modern science (as clearly indicated by **EPR**’s ‘Reality Criterion’ [2] [4]), Reality and Actuality are -even today- deemed synonyms. In Classical Physics only the *actual* was *real*, while the *probable* was a *potentiality* which could eventually become *actual* (‘realized’). But, oddly against our collective acumen, the *potential* (yet **unrealized**) was (via *deterministic* laws) as determined as the *actual*. Such a view is a persistent pernicious remnant of the Neopositivist School that assimilated Reality only with anthropic direct observation/measurement (which only detects *actualities*). As a result, to be real, all states and properties had to be/become actual and, to be/become actual, they had to be, could have been, or would be observed and/or measured in our **RT**’s spacetime. Ergo, using *probability* was only a *faute de mieux* to palliate **our** ignorance of those presumed actual values.

For a classical attribute we needed only one *random variable* to quantify the variability of the data collection process. In **QT/TOPI**, instead, the physical attribute is itself a random variable so two random variables are needed: one to quantify the attribute’s innate randomness and another to quantify the precision of the experimental technique. Conflating the two variabilities (attribute and experiment) is the main reason for the conceptual confusion surrounding the ‘Principle of Uncertainty’ [2] [4]. But for the attribute’s inherent variability to be experimentally confirmed, the precision of the experimental data had to be much higher than the attribute’s variability; otherwise, the latter would have been swamped by the former. It was the ability of researchers to set up

experiments involving ionization chambers, Wilson chambers, bubble chambers, photographic emulsions, photomultipliers, electron multipliers, etc. that produced astonishing new evidence.

In the simpler *discrete* case, to ascertain the innate stochastic nature of a physical attribute, we conduct a large number of ‘identical’ GIs and, for most of the system’s initial states (one by one) we find a large variability in the results. However, upon further analysis, we realize those results can be classified into groups clustering around some discrete values, each group with its own Mean and SD. The latter small variability corresponds to that of the GI process per se; the former larger variability unveils the intrinsic stochasticity of the physical property. Furthermore, for a few initial states we may find there is only one such group, i.e. the property behaves *deterministically*, with its variability ascribable only to experiment. In QT argot, they correspond to the *eigenstates* and *eigenvalues* of the operator associated with the physical property. In such cases, and only if the state around which the data points cluster is the same as the initial state, the GI is a TM [4] [5].

1.1. The Adoption of the Real Number Continuum

Continuity of time, space, and most physical magnitudes is a hypothesis about the physical world which has proven very fruitful – even in the microworld where the discrete nature of matter cannot be ignored. Mathematical *continuity* is an abstraction inspired by our sensorial experiences: we often experience two pairs of perceptions/measurements (A, B) and (B, C) such that A is indiscernible from B ($A = B$ by Leibniz’s *Identity of Indiscernibles*) and B is indistinguishable from C ($B = C$); however, our perception/instrumentation may distinguish A from C ($A \neq C$), imposing a blatant non-transitivity of the *equality* relation. This logical inconsistency is resolved with the abstract notion of mathematical *continuity*, by virtue of which magnitude differences so small that cannot be individually *perceived* by our senses or *measured* by our instrumentation (infinitesimals) still correspond to different values of the magnitude in a way that, upon accumulation (integration), become *perceivable* or *measurable* [16]. This valuable abstraction, which created a *non*-denumerable set of *non*-computable numbers, triggered the birth of the so-called ‘real’ number and the powerful differential and integral calculi.

A denumerable set of real numbers (e.g. $\pi, e, \sqrt{2}$) are computable but most are not – which means that their representation in any base (radix) contains an infinite sequence of digits that cannot be algorithmically calculated, viz it contains an infinite subsequence which is truly random. Thus, a single real number can represent an infinite amount of information and could be used, e.g. to codify all imaginable questions and their answers in every human language. Some abstraction! And, astonishingly, we use this infinitely powerful construct (with a random component) to represent a ‘definite’ value for a single physical property, initial state, position of a single point-object, etc. This is the source of the so-called deterministic *chaotic* behavior that systems display when their presumed *deterministic* evolution is hypersensitive to initial conditions or real-time perturbations, i.e. when the referred random digits of pertinent variables are significant.

It is also usually argued that, because a non-zero volume of space is needed to physically store information, while a point (zero volume) in our physical space is represented by three real numbers (each capable of ‘storing’ infinite information), then, as richly uttered by Gisin, “the so-called real number is not really real” [20]. Three ‘real’ with three different meanings, all applied to an abstract entity. In my humble opinion, *information* is different from its physical storage in the same way a *number* is different from its embodiment in a computer. As every mathematical tool, ‘real’ and even ‘imaginary’ numbers (irrespective of their highly misleading names [18]), represent Reality

well in many senses and poorly (even wrongly) in many others. For instance in QT, the eigenstates of *position* are Dirac's Delta 'functions' (Schwartz's distributions) which, not being normalizable, cannot represent physical pure states by themselves; even so, they are the building blocks in terms of which physical pure states are successfully depicted via superpositions (Equations 9).

Because of the mentioned identification of Reality with Actuality, Operationalism has played a crucial role in the conception and definition of many physical properties. For instance, Einstein, while conceiving RT, realized that the measurement of 'velocity' for distant events was logically vitiated – which is the reason behind his conventionality of *simultaneity*. In fact, the meaning of 'velocity' rests on the notions of *space interval* and *time interval*; however, the measurement of the latter requires *synchronization* at the distant endpoints of the former, which circularly requires the *velocity* of some synchronizing signal [15] [21] [22] [23] [1]. For reasons to be gradually revealed, we will refer to the *time* so defined by RT via the operation of measurement as 'R-Time'.

But, as the termini of the spatial interval get closer, the relevance of synchronization vanishes and, remarkably, the mathematical concepts of *continuity*, *limit of a sequence*, and *derivative* allow us to speak of, and work with, *velocities at a point in space* and *at a point in time* – concealing the need for physical (finite) intervals of both space and time. In this way, Newton gave to his intuitive ideas of 'spatial point', 'instant velocity', and 'instant acceleration' a rigorous *analytical* meaning. As for their *synthetic* significance, 'instant' and 'spatial point' are only useful abstractions, whose physical meaning and quantification change with the 'case in point' (pun intended). The same can be said for the abstraction of a 'point-object' for which the notions of *instant* velocity/acceleration as well as its *instant* physical properties are directly applied. Likewise for point-events.

Nonetheless, in practice, a temporal *rate of spatial change* requires at least **two** locations and **two** corresponding *instants*. The smaller the time interval is, the smaller the space interval is supposed to be, and the more effective the *ratio* is to estimate what the position was a little earlier (*retrodict*) or will be a little later (*predict*). This assertion is based on assuming the *continuity* of motion, which means that if we know/measure the *rate of change* based on the near *past* then we can use it to predict the near *future* and that, were we to perform the infinite sequence of *ratios* implicit in the definition, such a sequence would converge (both on the *past* and *future* sides) to a well-defined number declared to be the *instantaneous* velocity. Note as well that trying to compute the *ratio* for closer and closer *instants* requires higher and higher numerical *precision* in the values for closer *times* and the object's closer *positions*. The meaning of 'close' is contextual: claiming that all positions in the continuum between two close-enough locations exist in our **macroworld** (let alone in the **microworld**) is merely an *analytic* assertion. The mathematical geniuses of Newton and Leibniz allowed us to ignore the real process: a physical transition between two states that may or may **not** occur. Ergo (and this is a usually **un**recognized part of the century-long philosophical struggle), any differential equation is also (disguisedly) expressing the *present* in terms of the near *future*, instead of only the near *future* in terms of the *present*. Likewise for the rate of change of any other physical property whose *continuity* as a function of time is assumed.

Frequency (another temporal rate) and *wavenumber* (a spatial rate) of a wave are different: even though we speak as if they are properties the wave has at a given instant and location, *frequency* has no physical import unless we refer to a *time interval* including multiple cycles, and *wavenumber* has no physical meaning unless we refer to a *space interval* including several wavelengths. Ergo, they are not punctual but *whole* properties of the extended-in-spacetime object we call a wave. But unlike for time, space, and instant properties of point-objects, this assertion

has nothing to do with converting intervals into points via a mathematical limit, and all to do with the *meaning* of the concepts. Hence, even if we assume the *continuity* of space, time, frequency, and wavenumber, the mathematical trick played on *velocity* (via derivatives) does not work. In Social Statistics, we all know how to meaningfully interpret a ‘tenth of a person’ and how meaningless it becomes as the size of the ensemble decreases down to the individual – calling for a different theoretical approach. Similarly, in Physics, Bohr -to explain atomic spectra- replaced the derivative of *Energy* with respect to *Action* (tangent to the curve) with the secant so that, as *Action* and *Energy* increased, secant and tangent became indiscernible, and radiation frequencies for single/multiple-level energy drops approached the fundamental/harmonics of the electron’s mechanical frequency around the nucleus. The *high* energy and *small* relative changes, which are characteristic of the macroworld, explain the countless successes of Classical Physics [24] [19].

To conclude: the abstract ‘Real Number Continuum’ is as immensely useful as conceptually misleading. As will be proven throughout this series, keeping in mind the difference between Reality and its symbolic depiction is crucial to understand this marvelous Universe of ours.

1.2 From the Macroworld to the Microcosm

Regarding the concept of state in QT, Schrödinger said in 1935:

SCHR3: *The classical concept of state becomes lost, in that at most a well-chosen half of a complete set of variables can be assigned definite numerical values... It would be of no help to permit the model to vary quite “unclassically” perhaps to “jump”. Already for the single instant things go wrong... If I wish to ascribe to the model at each moment a definite (merely not exactly known to me) state, or (which is the same) to all determining parts definite (merely not exactly known to me) numerical values, then there is no supposition as to these numerical values to be imagined that would not conflict with some portion of quantum theoretical assertions [6].*

The brilliant mind of Schrödinger presaged/condensed both Bell’s theorem and Bell-Kochen-Specker (BKS) theorems [25] [26] [27] [1]. So he was right but, philosophically, he was wrong. In full agreement with EPR [2], Schrödinger believed that: a) only properties with “definite numerical values” are real (*probabilities* are not); and b) being *probabilities* merely epistemic (“definite merely not exactly known to me numerical values”), QT is not only **incomplete** à la EPR, but internally inconsistent and, ergo, wrong. We will show that, per TOPI, both premises and conclusions are flawed and the direct result of believing that there is no Reality without Actuality.

1.2.1 The Important Notion of Milieu Basis (MB)

Having shown that, even in our macroworld, many physical properties are not inherent in the object but determined jointly with its milieu, the notion of Milieu Basis (MB) is essential in both Classical and Quantum Physics. Despite their many drastic differences, both classical and quantum *states* are conceptually comprehensive in the sense that they incorporate all possible milieus (PIs) the object might encounter. This is so despite the object’s *current* state being fully specified (deterministically or stochastically) by its *previous* PI and -in general- not all its physical properties being *defined* for all states. Except in the few cases in which the **milieu is irrelevant**, the *current* MB for a given object is pinpointed solely by its *current milieu* (i.e. irrespective of its *current* state) as a distinct set containing its *next* states.

In **QT** lingo, the states in the *current* MB are the common *eigenvectors* of all the commutative *Operators* (speciously called ‘Observables’) associated with the *current* milieu (**PI**). Each *operator* corresponds to a physical *property*, with the former’s *eigenvalues* being the latter’s possible *next* values. Among a multitude of bases, the MB is the only one that, when used to express the object’s *current* state, not only *directly* reveals its *next* states, but also *directly* quantifies their *probable* transitions. Of course, if the physical state is mathematically represented as a member of a vector space (as it is in **QT**), any other basis -though *indirectly*- could do the same. Let us understand this generic concept and its consequences with some concrete instantiations.

1.2.2 The Galton/Popper Bean Machine and its Milieu Bases

Under **TOPI**, it is not the Universe that is *deterministic* while we can use *probability* to mitigate our ignorance: it is our Universe that is inherently *stochastic* and, on many occasions (particularly in our *macroworld*), we can successfully suppose it is *deterministic*. Most science museums display some embodiment of Galton’s quincunx (bean machine) as a practical illustration of the ‘Central Limit Theorem’ in Probability Theory. Karl Popper worked on the interpretation of **QT** with some of his ideas explained using his ‘pinboard’ [28] [29] [30]. I will stochastically predict how a ball traverses the device (**Figure 1/right**) under a slight uniform gravity gradient along the columns. Remarkably, despite the *macroscopic* nature of the ball and its milieu, the appearance of some of the philosophical enigmas of **QT** (still controversial after a century) is unavoidable.

A discrete *spacetime* reference frame is naturally set by pins and holes, with the first coordinate for vertical position (and discrete *time*) and the second for horizontal position. **Figure 1** shows 14 rows and 25 columns. This grid of times and horizontal positions are operationally defined and measured per **RT**’s Einstein’s *synchronization* technique (Part IV [1]), allowing us to correlate *actual* positions of the ball with *actual R-Times*. Though we could certainly define a finer grid, due to the relative size of ball and holes, the already-invalid point-object abstraction would get even worse so the classical ball’s state, defined by the punctual position/momentum of its mass center, fails. To name a few: mass, size, shape, and elastic properties of ball and pins would be crucial for attempting a *deterministic* description. But minuscule differences among pins, and how the ball glances off them would drastically change the bin into which it finally falls. Whether you insist on the existence of the chimerical Laplace’s Demon or not, it is a matter of moot opinion. Moreover, the number of variables to be included in the ball’s state and milieu, their needed infinite precision, and the ensuing impossibility of the reproducibility test (vital to assess the theory), justify my stance that this *macro-system* -despite common wisdom- is ontically stochastic.

In sum, once the sensitivity of the system’s evolution to initial conditions, physical properties, and milieu reaches the random digits in their numerical representations, we cannot claim ignorance about something innately undetermined, so probability cannot be epistemic. Gisin reaches the same conclusion that Classical Physics is inherently nondeterministic through ‘Intuitionistic Mathematics’, a school of thought that considers a real number not an entity whose infinite digits are given all at once (David Hilbert’s universally accepted view) but a temporal process per se (Luitzen Brouwer’s stance) [31] [32] [33]. In my modest opinion, such a radical view is not necessary: **TOPI** retains Hilbert’s stance by treating abstract states/properties as random variables.

We define the ball’s *current* state in a way that, instead of univocally determining its *next* state, it determines (jointly with the milieu) the *probabilities* for all possible *next* states. When the ball is at (0,13), even though right after glancing off a pin in a row the ball can only interact with its

contiguous pins in the row below (its *local* milieu), there are 78 possible ball/pin interactions (**PIs**) before it reaches one of the 13 collecting bins. This is the *global* milieu. Our hypotheses are: a) all local **PIs** are *indistinguishable* irrespectively of pin and ball genidentities and positions in the machine [18] [19]; b) all local **PIs** are *independent*; and c) the probabilities for the ball to fall left or right of a pin are equal. With those premises, all 78 local **PIs** can be described with structurally the same state-transition equation. Because the ball's position is important as one of its properties for each *state*, I will denote $[j, k]$ the ball's *state* when it is about to hit the pin located at (j, k) , and express it (capriciously for now) as follows:

$$[j, k] = (1/2)[j + 1, k - 1] + (1/2)[j + 1, k + 1] \quad (1)$$

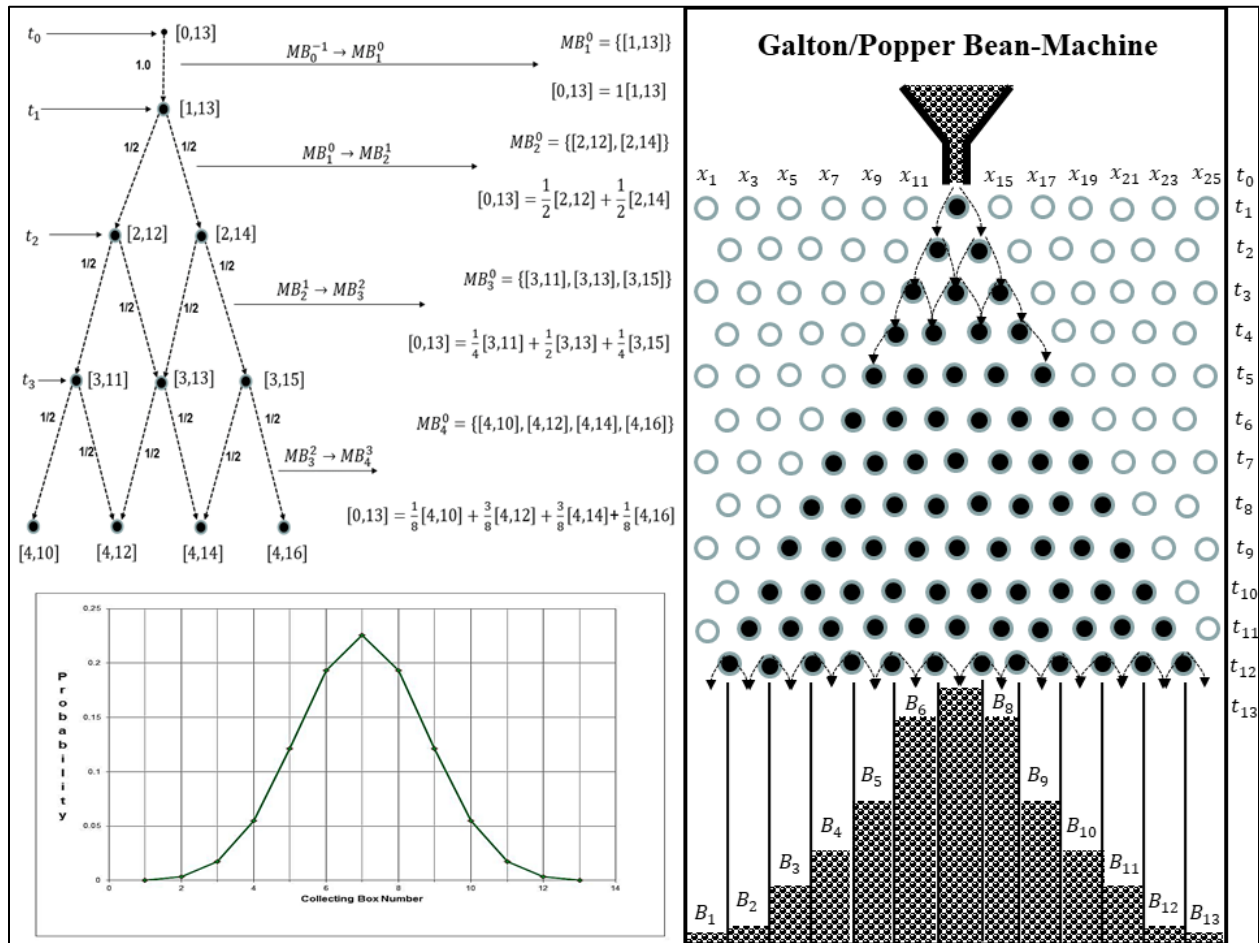

Figure 1: Probability of a Single Macro-object in Galton's Quincunx

I have expressed the *current* state as a convex superposition of its two possible *next* states. The adjective 'convex' means that the coefficients in the superposition are real non-negative numbers adding to unity. This must be so because we chose them to be probabilities. In plain English, if the ball hits a pin in a row, then there is a 50% chance of subsequently hitting the pin to the left, and a 50% chance of hitting the pin to the right in the row right below. By extension, we will refer to these states as 'convex states'. Note a convex superposition is not of the type used in **QT** for the so-called 'pure' states, in which the coefficients are complex numbers whose squared moduli are the probabilities. Such superpositions would not achieve our purpose for this system, with

Schrödinger's Equation useless as well. To distinguish them, we will call the latter type '2-superpositions' and the convex type '1-superpositions'. We will see that the so-called *mixed* states and our *co-states* of composite quantons are also expressible as 1-superpositions. Likewise (and against common wisdom) for the radioactive nucleus controlling the fate of the poor cat in **Schrödinger's contraption**.

With the ordinary meaning of the words 'actual' and 'probable', we could say that at **R-Time** j the state $[j, k]$ is *actual*, while both states on the right side of **Equation 1** are *probable* because one of them shall become *actual* at **R-Time** $j + 1$. Gradually reducing the gravity gradient, which of the *probable* states would become *actual* could be ascertained by us in real time well before the ball reaches the row below – realizing their *probable* status only exists in the blurry narrow spacetime region in which the ball/pin encounter occurs. In sum, though for most of the **R-Time** in the quincunx the ball's state is *actual*, there are poorly defined small spacetime regions in which two *probable* states coexist as such. **TOPI** contends that the two (in this case ephemeral) states during the **PI** are ontically probable, i.e. *probable* not because they may eventually become *actual*, but because, though evanescent, they are as real as the longer-lasting *actual* ones between **PIs** are.

Note that: (a) before and during the **PI** at pin (j, k) , the ball is not in two *actual* states at once (let alone two *actual* positions); it is in the *actual* state $[j, k]$ that encompasses, and is expressed in terms of, its two real probable next states; (b) each *probable* next state is correlated with a cluster of *physical* paths all leading to either the pin on the left or to the pin on the right in the next row; (c) after the **PI**, only one of the two *probable* states becomes *actual*. Though as real as the ball is, its *states* (and *properties*) are only attributes that come and go as the ball evolves so there is no magic in the 'disappearance' of one of the *probable* states. An *actual* transition from state $[j, k]$ to either state $[j + 1, k - 1]$ or state $[j + 1, k + 1]$ has occurred. However, due to their evanescence, such positing of reality for *probable* states of a macro-ball is inconsequential (even whimsical), explaining why our commonsense directs us to presuppose that the ball's state is always *actual*, i.e. always observable and/or measurable (at least in principle). Assertions (a) and (b) illustrate what we will call a 'Pure Transformation Interaction' (**PTI**), while (c) shows what we will call a 'Pure Detection Interaction' (**PDI**). Both are parts of a typical 'Gauge Interaction' (**GI**) [4] [5].

From **Equation 1**, the state-space for the local **PI** at (j, k) is a bidimensional real vector space with its *current Milieu Basis* $MB_{j+1}^j = \{[j + 1, k - 1], [j + 1, k + 1]\}$. We will refer to the states of a basis as *eigenstates*. Notice that: a) the transition *probabilities* are given directly by the coefficients; b) **no** *current* state can belong to the *current MB*, so the *next* state is always different from the *current* state; c) except for the initial ball discharge onto the first pin, the **MB** cardinality is greater than unity; and d) the *current* physical state, expressed as a *superposition* of eigenstates for the *current PI*, is also an *eigenstate* for the *previous PI* (i.e. a member of MB_j^{j-1}). The *same* physical state $[j, k]$ is expressed in *different* bases, i.e. via *different superpositions*. Let us now see that this unique but simple mathematical representation is not as capricious as it seems.

Looking at **Figure 1 (top-left)**, we keep the *initial* state fixed at $[0, 13]$ ($t = t_0$), whose local milieu basis is $MB_1^0 = \{[1, 13]\}$, and change the milieu by sequentially redefining the *final* time until the ball is about to fall into a collecting box ($t = t_{12}$). In the process, new milieu bases $MB_2^0 = \{[2, 12], [2, 14]\}$; $MB_3^0 = \{[3, 11], [3, 13], [3, 15]\}$... are determined by the augmented set of possible **PIs** in each row, and the mathematical expression for the initial state $[0, 13]$ in terms of the subsequent bases can be efficiently updated by recursively applying **Equation 1**:

$$\begin{aligned}
[0,13] = [1,13] &= \frac{1}{2}[2,12] + \frac{1}{2}[2,14] \quad \Rightarrow \quad [0,13] = \frac{1}{4}[3,11] + \frac{1}{2}[3,13] + \frac{1}{4}[3,15] \\
&\quad \Downarrow \\
[0,13] &= \frac{1}{8}[4,10] + \frac{3}{8}[4,12] + \frac{3}{8}[4,14] + \frac{1}{8}[4,16] \quad (2) \\
&\quad \vdots \\
&\quad \Downarrow \\
[0,13] &= \dots \quad 0.12[13,9] + 0.19[13,11] + 0.23[3,13] + 0.19[13,15] + 0.12[13,17] \quad \dots
\end{aligned}$$

We started spanning the *initial* state $[0,13]$ in terms of the only *eigenstate* in $MB_1^0 = \{[1,13]\}$ and ended expressing the *same* state $[0,13]$ in terms of the 13 *eigenstates* (collection bins) in MB_{13}^0 . During our intellectual process, the *initial* state did not change but, as **R-Time** elapsed, the milieu did change – with its corresponding change of **MB**, i.e. the possible next states. The last state-transition equation corresponds to a **PI** in which the ball interacts with the whole pinboard. At a given iteration, each coefficient of the superposition of *eigenstates* gave us the probability for the ball (if started in $[0,13]$) to be in that *eigenstate*, i.e. to hit that pin when reaching that row. All superpositions represent the same initial state of the ball, but the coefficients are the real probabilities only when using the basis determined by the ball’s current milieu. In **QT**, this temporal description is known as the ‘Heisenberg’s picture’ in which the *initial* state does *not* evolve in time, while the *Operator* whose *eigenvectors* define the **MB** does change in time.

Clearly, using the generic local **PI** (Equation 1) plus the global topology² of the network of **PIs**, we can predict the probability for the ball to reach any state from any state. The convex *superposition* of states offers a recursive formalism that covertly adds the probabilities of *disjunctive* (\cup) events (mutually exclusive paths to hit a pin) and multiplies the probabilities of *conjunctive* (\cap) events (pins hit within each path). This is the pragmatic reason behind expressing the *current* state as a 1-superposition of *next* states in Equation 1.

Had we playfully referred to the set of all coefficients in the final superposition (Equation 2 - bottom) as the ‘ ψ -wavefunction’, it would simply be the **PD** for the *next* states when the *current* state is $[0,13]$ and the milieu is the whole pinboard – regardless of which *actual* path the ball would undergo before reaching a bin. And the *actual* bin the ball falls in is, of course, not affected by our confining the quincunx in a “**room of steel**” only to be open one hour after the ball traversed the machine. To assess the accuracy of the *predicted* **PD**, we could run a single ball a large number of times (recording the bin where it fell and feeding it back to the quincunx) or filling up the feeder with ‘identical’ balls so we could see in real time how they pile up while approximating the Gaussian **PD**. In either case, about 23% of the balls would be in bin B7, about 19% in B6 and B8, about 12% in B5 and B9, and so forth (Figure 1 - bottom left and right).

Now assume we, “without in any way disturbing the system” [2] [4], *experimentally* determine that at time, say t_3 , the ball is about to hit pin (3,11), i.e. it is in state $[3,11]$. Is this *knowledge* of ours affecting the future evolution of the ball? Of course not. It is not our *knowledge* but the fact that the ball is now in state $[3,11]$ and, ergo, the last two collector bins B_{12} and B_{13} are now unreachable by the ball. Obviously, such state/milieu change would have occurred anyway without

² By ‘topology’ we mean the connectedness structure among the **PIs** (which outputs go to which inputs).

our cognition. If we ignore our *knowledge*, our original probabilities are still epistemically useful were we to launch a large set of balls from the feeder, because the fractions of balls in the bins would agree with the probabilities in [Equation 2](#) (bottom). However, if -of all those runs- we only tabulated the ones for which the ball *did* hit pin (3,11), the new fractions would *not* agree with the predicted **PD**. The *current* state encompasses all possible milieus, but the **PD** depends on both the *current* state and the *current* milieu. You may ignore or not be aware of what has happened, but Nature does neither.

But if we accounted for the fact that the ball did hit pin (3,11) at t_3 , the superposition for $[0,13] = (1/4)[3,11] + (1/2)[3,13] + (1/4)[3,15]$ *appears* to have *collapsed* to the single eigenstate [3,11]. There is however no mysterious physical ‘collapse of the wavefunction’ here: just a physical transition from a *single actual* state [0,13] to a *single actual* state [3,11] because only one of the three probable states may and has become actual. The latter transition is the combined result of two previous transitions at times t_1 and t_2 . But, with this new *current* state, we can now iteratively apply [Equation 1](#) again arriving at an expression for [3,11] in terms of the eigenstates in row 13 (bins) with different coefficients (probabilities), i.e. with a different wavefunction. The probabilities of reaching the last two bins on the right are now zero as they should be once the ball hits the pin (3,11). The ball’s state evolves with **R-Time**, and this fact has nothing to do with our reference frame or state of knowledge. In **QT**, this temporal description is known as the ‘Schrödinger’s picture’ in which the *current* state (wavefunction) does evolve in time, while the operator whose eigenvectors define the **MB** (comprising all 78 eigenstates) does not. The coefficients of the superposition (state components) change with time. It is formally equivalent to the previously described Heisenberg’s picture. Notice though that the temporal evolution for the state allows for some of its initial non-zero components to evolve into zero, further invalidating [Schrödinger’s Equation](#).

Here is a different change of milieu: if we -as the ball travels- laterally sloped the quincunx to add a slight gravity gradient along the rows, would its *probability* of reaching one of the bins change? Yes, it would because, depending upon toward which side the quincunx was tilted, one of the coefficients in [Equation 1](#) must be higher no matter where the ball was at that moment. The **PD** in [Figure 1](#) would be altered. We still could claim Laplace’s Superman powers and state that if we knew enough about the system, its evolution could be deterministically predicted. Under such wishful attitude, *probability* would be merely *epistemic* but, even so, by its having factually changed for the single ball upon an abrupt change in milieu, a cogent case could be made against its being just a figment of our imagination or merely a statistical property of an ensemble of balls.

Furthermore, were we to remove the pin at, say, location (6,12), [Equation 1](#) would not be valid for state [6,12] because the ball would go straight down the hole (7,12). The superposition for any current state $[j, k]$ ($j = 1,5$) in terms of MB_{13}^j might change (depending on k), with the **PD** for a *single* ball changing accordingly. Of course, the ball does not ‘know’ whether the pin is there or not. For the photon, Feynman colorfully argued that, by scraping away parts of a mirror (making a diffraction grating), it reflected “where you didn’t expect any reflection” [34]. We see that it happens even with a macro-object. It seems mindboggling because we have been pre-programmed to think in a certain way (in terms of dynamic causal chains in spacetime [1]) for centuries.

Summing up: the *probability* of reaching a collector bin for a single run is a *property* of the ball’s state plus its milieu. The *current* state is probabilistically determined by the *previous* **PI** (it is in the *previous* **MB**), but the *current* **PD** for the *next* states depends on both the *current* state and

the *current MB*. Upon the removal of a pin, it is the *milieu* that changes with *no need* for any physical ‘communication’ between the places where the pin was removed and where the ball was at the time. If you insisted on postulating a causal dynamic action between the pin-removal event and the change in the *PD* for the ball, then you would have to embrace Einstein’s ‘spooky action at a distance’ (or at least superluminal causal chains) as a ubiquitous occurrence in our quotidian activities. It is certainly ubiquitous and real, but not a causal dynamic process in *RT*-spacetime; ‘nonlocality’ or ‘spacelike interaction’ are better terms. *EPR* removed nonlocality from *QT*’s *Ontology* by fiat because *RT*, as conceived by Einstein, could not predict it [4] [5] [2]. Part IV reconsiders the notion of causal relation and reveals how to complete *RT* in the light of *QT* [1].

1.2.2.1 Does the Concept of Classical State become Lost in the Concept of Convex State?

In Schrödinger’s sense (*SCHR3*): *no*, it does not get lost. Not being deterministic, for every *current* state, several *next* states exist with different probabilities, with the convex superposition encoding those *next* states and the state-transition *PD*. The system’s *stochasticity*, i.e. the coexistence of the ontically *probable* states, belongs to a blurry vanishingly small spacetime region in which each *PI* occurs at a pin. No *current* state belongs to the *current MB*, all states at each *R-Time* can be considered *actual*, and all properties are determined for each *actual* state, with all *potential* states/properties well defined but *not* determined until they become *actual* in due *R-Time*. Given initial and final states, there are multiple *actual* (mutually exclusive) trajectories, each one with a different probability. Yet, for any state, “definite numerical values” can be assigned to a “complete set of variables”. Clearly, Schrödinger’s denounced conflict does *not* exist, so *stochasticity* per se cannot be the culprit. However, the quantum state *SCHR3* refers to is what *QT* calls a ‘pure’ state, not our ‘convex’ state for the quincunx’s ball. In fact, as we saw, despite our contention that *probable* states in the quincunx are ontic, it is inconsequential and ergo sensible to believe that the ball’s convex state is *actual* at all conceivable times – in which case *probability* can be considered as epistemic (Einstein’s and Schrodinger’s philosophical view).

1.2.3 The Pendulum and its Milieu Bases

Now we turn to the classical harmonic oscillator: a mechanical system whose dynamics is so stable that a non-chaotic *deterministic* description is easily attainable. To describe the small-swing motion of a pendulum’s bob, we assume it is an ideal point-object of mass m that interacts with an ideal milieu comprising: a) ideal frictionless air; b) an ideal rigid line-rod of length L that can frictionlessly oscillate in a plane around a fixed point, and to which the bob is rigidly attached; and c) the local gravity field \vec{g} , always exerting on the point-bob a vertical-down force $m\vec{g}$. Being the motion of the point-bob planar, the gravity force $m\vec{g}$ to which it is exposed can be decomposed as a superposition of *any* two non-parallel vectors, i.e. *any* basis for \mathbb{R}^2 . But, for the position of the point-bob at which the line-rod makes an angle θ with the vertical (*Figure 2*/left), there is one distinct basis that cogently relates the theory’s *Ontology*, *Foundation*, and *Structure* [4] – allowing for straight prediction/explanation. Simpler: this unique basis for the gravity force allows to *easily* apply motion and gravitation laws. It comprises two unit-vectors, one parallel to the line-rod (\hat{r}) along which the point-bob cannot move, and the other, orthogonal to it (\hat{t}), which is the only direction along which the bob may move. The basis $\{\hat{r}, \hat{t}\}$ changes with the bob’s position.

From *Figure 2*, with θ negative to the left of the vertical, $m\vec{g} = mg(\cos\theta\hat{r} - \sin\theta\hat{t})$, and with the approximation for small swings $\sin\theta \cong \theta$, we get $m\vec{g} = mg\cos\theta\hat{r} - mg\theta\hat{t}$. Because of the

‘rigidity’ of the line-rod, the first component is counterbalanced impeding the bob to move along \hat{r} , while the second component is the restoring force responsible for the bob’s acceleration.

Being $q = L\theta$ the pathlength covered by the bob and $p = m\dot{q}$ its momentum, Newton’s Second Law becomes: $\dot{p} + (mg/L)q = 0$. Hence, the bob’s classical state-space is bidimensional and defined by the numerical values of q and p . Another way to describe the motion is using Hamiltonian dynamic equations in state-space:

$$H(q, p) = \frac{p^2}{2m} + \left(\frac{mg}{2L}\right) q^2 \quad \Rightarrow \quad \dot{q} = \frac{\partial H}{\partial p} = \frac{p}{m} \quad ; \quad \dot{p} = -\frac{\partial H}{\partial q} = -\frac{mgq}{L}$$

$$\Downarrow \quad (3)$$

$$\dot{p} + (mg/L)q = 0 \quad \Rightarrow \quad \underline{s} = \begin{bmatrix} q \\ p \end{bmatrix} \quad \Rightarrow \quad \dot{\underline{s}} = \begin{bmatrix} 0 & 1/m \\ -mg/L & 0 \end{bmatrix} \underline{s} = \underline{A} \underline{s} \quad \Rightarrow \quad \underline{s} = e^{\underline{A}t} \underline{s}_0$$

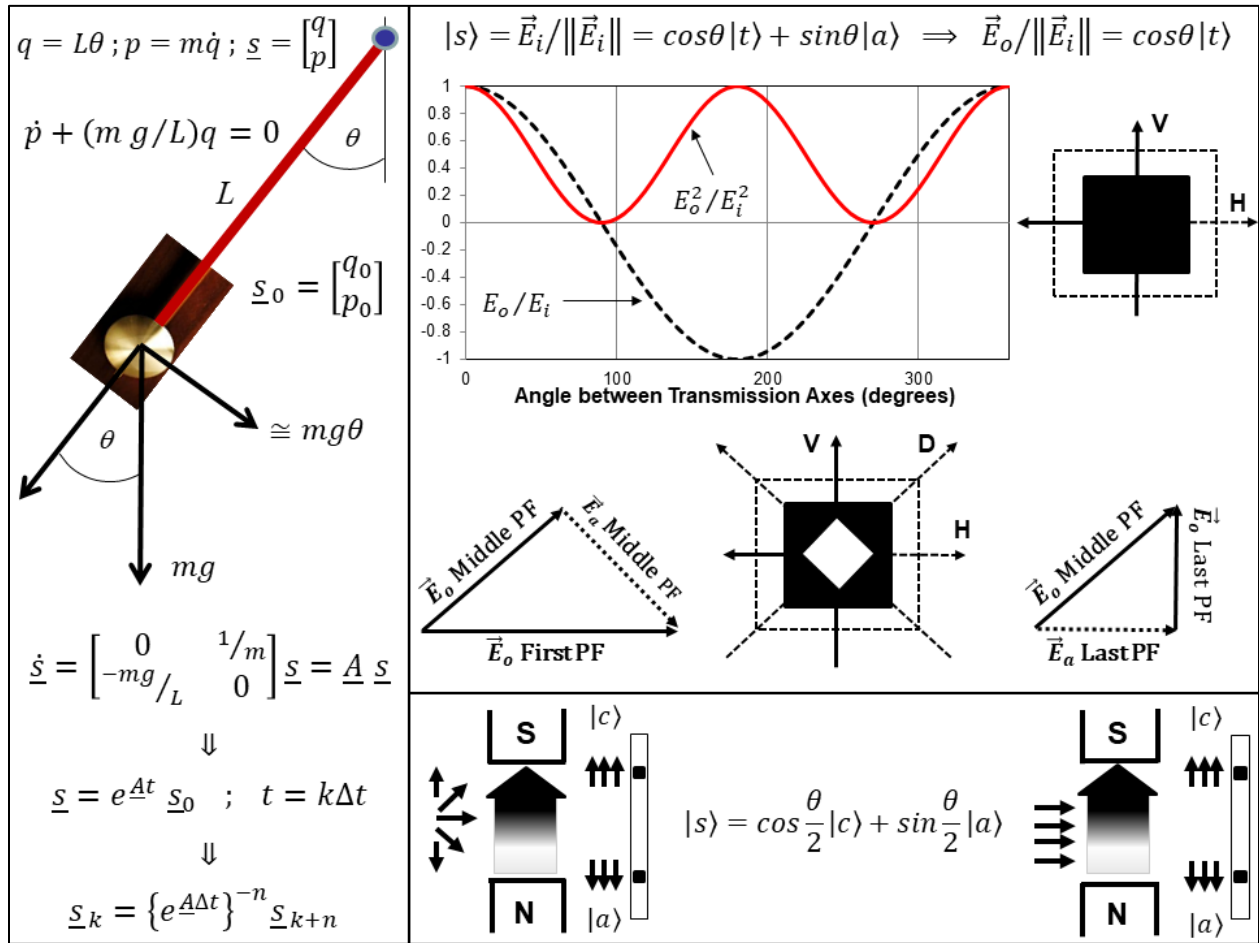

Figure 2: Milieu Bases for a Pendulum, a Light Beam, and an Atomic Beam

The first line in Equations 3 tells us that the system state (q, p) evolves infinitesimally to the next state via a repeated *transformation* the heart of which is the Hamiltonian function $H(q, p)$. Hamilton’s equations establish a *mapping* of lawful transitions from one *state* to another in state-space. This feature underscores the similarities Hamilton discovered between mechanical motion

and wave propagation; it is homologous to Huygens-Fresnel technique for the construction of the equiphase surfaces in Wave Optics. Notice that, because friction was neglected, the total mechanical energy is conserved and the gravity force $-mgq/L$ is calculated as $-\partial V/\partial q$, with the potential $V(q) = (mg/2L)q^2$. It is the potential $V(q)$ in the Hamiltonian that conveys the changing milieu as the bob oscillates – with the corresponding changing basis $\{\hat{r}, \hat{t}\}$ for the force.

The second line in **Equations 3** shows that, representing the state as a column vector, the equation of motion becomes a first-order matrix differential equation that is structurally isomorphic to **Schrödinger's Equation**, and whose solution is the ubiquitous exponential $\underline{s} = e^{\underline{A}t}\underline{s}_0$, with the initial state being $\underline{s}_0 = [q_0 \ p_0]^T$. Discretizing time via $t = k\Delta t$, we obtain:

$$\underline{s}_{k+1} = e^{\underline{A}\Delta t}\underline{s}_k \Leftrightarrow \underline{s}_k = e^{-\underline{A}\Delta t}\underline{s}_{k+1} \Rightarrow \underline{s}_{k+n} = \{e^{\underline{A}\Delta t}\}^n \underline{s}_k \Leftrightarrow \underline{s}_k = \{e^{\underline{A}\Delta t}\}^{-n} \underline{s}_{k+n} \quad (4)$$

The first recursive equation expresses the **only** possible *next* state \underline{s}_{k+1} given the *current* state \underline{s}_k ; the second equivalently expresses the **only** possible *previous* state \underline{s}_k given a *current* state \underline{s}_{k+1} . The next two equations relate two states separated by n time steps: after(before) n steps, the factor relating the two states is the contiguous-state exponential to the $n(-n)$ power. Evidently, with no heat dissipation, the bob/milieu **PI** is *reversible*: there is a one-to-one relationship between *initial states* and corresponding *trajectories*, so there is only one lawful *trajectory* and *initial state* with and from which the bob could have reached a given *final state* and, ergo, *retrodiction* is as *univocal* as *prediction*. In the real macroworld, heat dissipation destroys such a bijection.

Time discretization created a grid of *actual* times, positions, and momenta operationally defined/measured per **RT's** *synchronization* technique (Part IV [1]). This technique allows to correlate *actual* states of the bob with *actual R-Times*. It is presumed to be valid for arbitrarily small Δt (implicit in the notion of momentum). Hence, the *current* state is deemed always *actual* and **real**, while future states are *potential* because -though not real yet- they will unavoidably become *actual* and **real** after some elapsed time. Despite **not** being real in Classical Physics, *potentiality* is as determined as *actuality* because the former is fixed by *deterministic* laws. A *potential* state must become *actual*. Again: this is plainly against our experience in everyday life – though a steadfast determinist would insist that you are simply not knowledgeable enough.

From the special basis $\{\hat{r}, \hat{t}\}$ for the gravity force and the dynamic **Equations 3**, we can infer what the **MB** for each *current* classical state is. Because the *next* state is univocally determined, the *current* MB_{k+1}^k contains only one state, viz $\underline{s}_{k+1} = e^{\underline{A}\Delta t}\underline{s}_k$. Even more, unless initially the rod is vertical and in repose ($\underline{s}_0 = [0,0]^T$) -in which case there is no evolution- **no** two **MBs** have common states. And, because position and momentum are components of the classical state, both are determined not only for the *current actual* state but for every *potential* state well before they become *actual*. In fact, in agreement with **SCHR3**, “a complete set of variables” have “definite numerical values” at “each moment”. Furthermore, they are determined all the way back to the initial state and well beyond into the future (while the system remains closed). Obviously, though we already proved that *stochasticity* is not the culprit for Schrödinger's denounced conflict, he had *determinism* in mind when describing “the classical concept of state”. Let us now prove that **no** state à la **QT** can be conceived for a *deterministic* system.

1.2.3.1 There is no State à la QT for the Deterministic Evolution of the Pendulum

Let us understand the difference between the concepts of state in Classical and Quantum theories by contriving a state à la QT for the deterministic pendulum. Please note that I am not trying to prove how its deterministic evolution can be obtained using the QT formalism. Indeed, in the latter, Newton’s Second Law takes the form $d\langle\mathcal{P}\rangle/dt = -\langle\partial\mathcal{V}/\partial q\rangle$ with \mathcal{P} and \mathcal{V} the momentum and potential operators. Under appropriate conditions (typically valid for macro-systems only if heat dissipation is negligible), the equation becomes $d\langle\mathcal{P}\rangle/dt = -\partial\mathcal{V}(\langle q\rangle)/\partial\langle q\rangle$ which is our equation $\dot{p} + (mg/L)q = 0$ – if we think of p and q as the mean values of their respective random variables. What I am trying to do, instead, is to show that it is impossible to use the concept of quantum state to directly describe the dynamics of a *deterministic* system.

Loosely using Dirac’s ket-notation, we will refer to such state as $|s_k\rangle$ (‘quantic’ state at time $k\Delta t$). Per QT, any representation of this ‘quantic’ *current* state would have to directly reflect the transition probability to the *next* state $|s_{k+1}\rangle$ via a linear relation between the two. Also, this new state would have to **indirectly** reflect the components of the classical state \underline{s}_k , not as its own components but as physical properties associated with it. But being the classical theory deterministic, $\text{MB}_{k+1}^k = \{|s_{k+1}\rangle\}$ and the probability for the transition from the *current* state to the only *next* state must be unity. Hence, the coefficient for the inevitable *next* state in the superposition must be unity. In symbols, to meet those QT requirements, we set the following correspondences, leading to a trivial and absurd state-transition equation:

$$\begin{aligned} |s_k\rangle &\leftrightarrow \underline{s}_k = e^{A\Delta t}\underline{s}_{k-1} & ; & & |s_{k+1}\rangle &\leftrightarrow \underline{s}_{k+1} = e^{A\Delta t}\underline{s}_k \\ Pr(\underline{s}_k/\underline{s}_{k-1} = 1) & & ; & & Pr(\underline{s}_{k+1}/\underline{s}_k = 1) & \\ & & \Downarrow & & & \\ & & |s_k\rangle = 1 \cdot |s_{k+1}\rangle & & & \end{aligned} \quad (5)$$

This is of course pure nonsense because, despite the bottom state-transition equation saying that our concocted ‘quantic’ state does not change with time, the physical properties q and p (the components of the classical state) do change *deterministically* via the correspondences in the first line. Such a description would certainly be incomplete as EPR claimed [2] [4] [5]. The reason is that in QT the state-transition equation (superposition) is a relation among the *current* state and the probable *next* states, **not** between actual different states. In QT/TOPI argot: *next* and *current* states can be equal only when the *current* state belongs to the *current* MB while, in this system, contiguous MBs are disjoint (except, when the bob starts from repose in the vertical position). As long as both q and p have different “definite numerical values” at “each moment” (SCHR3), the state-transition Equation 5 (bottom) will remain absurd when describing a *deterministic* system.

Wrapping up, from the two macrosystems we have so far discussed, conventional wisdom seems to suggest that Schrödinger’s conflict with the classical concept of state may only appear in the microworld. To debunk such a belief and uncover the origins of the quantic concept of a *pure* state, we need to look at macro-objects whose extrapolation down to the *single* quanton is (unlike for the pendulum and the quincunx) not only conceptually sensible but technologically feasible. High-intensity light and atomic beams are cases in point.

1.2.4 Milieu Bases for High-Intensity Light

Only in our macroworld is the notion of electric and magnetic fields propagating as a wave valid to describe/explain light. Math depiction of electric fields includes complex numbers, whose *moduli* and *phases* allow us to describe/understand their *interference*, after which the squared modulus of the net electric field (light intensity) at different places on a screen is responsible for the distinctive light/dark pattern upon diffraction. Despite the aura of magic Born's Rule enjoys, the underscored 'squared' and 'net' qualifiers for the field is all we need to understand why such rule governs the microworld in a way that everything we know of the macroworld still is valid.

Light emission is a *non-continuous* process because a *real* monochromatic source, instead of an infinitely long harmonic wave (an obvious abstraction), *intermittently* emits trains made of millions of cycles with random and abrupt changes in *phase*. In addition, because a *real* light source comprises trillions of atoms whose radiations are *uncorrelated*, the electric vector does not stay in the same plane while spatially oscillating but varies haphazardly from train to train. This is so for the sun, flames, and incandescent lamps, and we say such light is *unpolarized*. We also say the macro-object called light is in a *mixed* state because it can be represented as a uniform mixture of all possible linear polarizations – i.e. the electric vector oscillates along straight lines which, from train to train, make all possible angles with respect to a reference in the plane orthogonal to the propagation axis. The distance the wave travels with the same polarization and phase is the 'coherence length' (a few micrometers for sunlight). Laser light is so special precisely because it can sustain extended tempo-spatial coherence.

Despite wave propagation being tridimensional, its polarization can be fully described in a plane. Besides, any linearly polarized wave can be expressed as a combination of two waves linearly polarized in two orthogonal directions with the same phase. It can also be expressed as a superposition of right-handed and left-handed circularly polarized waves in equal proportions and appropriate phases and, by varying those proportions and phases, any elliptically polarized wave can be obtained. Conversely, any circularly/elliptically polarized wave can be synthesized by suitably combining two orthogonal linearly polarized waves with an appropriate phase difference. Tersely: the state-space for the polarization of high-intensity light is bidimensional.

1.2.4.1 Polarizing Filters

Sunglasses transmit vertically polarized light and absorb horizontally polarized light. They are made of a plastic sheet with long molecular chains, which has been heated, mechanically stretched to align the molecules, cemented to a rigid plastic, and dipped into a solution of iodine. If the light's electric field is parallel to the molecular chain (stretch direction), valence electrons from the iodine dopant oscillate, energy is degraded into heat, and light is absorbed; if the field is orthogonal to the stretch direction, electrons hardly oscillate, energy is not degraded, and light goes through. Thus, the material's transmission (optic) axis is orthogonal to its stretch (absorption) axis. A plastic sheet so made is called a polarizing filter (PF) with the following general behavior: 1) the electric vector after the PF is along its optic axis and, ergo, light comes out fully and linearly polarized; 2) without rotating the PF, the intensity coming out is a maximum when the PF sheet is perpendicular to the light propagation axis; 3) rotating the PF while perpendicular to the light propagation axis changes the output intensity; and 4) the rest of the light intensity is absorbed by the PF, degrading into heat.

Once the input electric vector is projected along the plane defined by the PF, it can be decomposed along *any* two independent (non-parallel) directions in such a plane (a basis for \mathbb{R}^2); however, there is again one distinct basis: the stretch (absorption) and its orthogonal (transmission) axes. Those two directions can be represented by unit-vectors, i.e. vectors whose Euclidean norm is unity and for which, despite still dealing with legions of photons, I will use Dirac’s ket-notation (you will see why). Let us call $|t\rangle$ the transmission and $|a\rangle$ the absorption axes so that $\text{MB} = \{|t\rangle, |a\rangle\}$. This basis is determined in our physical space exclusively by the light’s *milieu* (PF), irrespective of the light’s input electric field. Correspondingly, and because light *intensity* is proportional to the *squared* modulus of the electric field, we define the light input state $|s\rangle$ also as a unit-vector via the Euclidean norm. Doing so, the *square* of each of its components is the ratio between the *intensities* of component and total input fields with their sum equal to unity. This is drastically different to the **quincunx’s state**, in which the straight sum of its components was unity.

Figure 2 (top right) shows how the input (*current*) state $|s\rangle$ is expressed as a superposition of the eigenstates in the **MB**, where θ is the angle between the input electric vector \vec{E}_i and the **PF**’s optic axis $|t\rangle$. Clearly, once light went through a **PF** at a given orientation, it will go fully through subsequent **PFs** with the *same* orientation ($\theta = 0$), preserving its polarization. In such a case, light’s input state belongs to the **MB** and passes through without changing its state, i.e. the *current* state is an eigenstate for the **PI**, and the **GI** is a **TM**. Note the difference with the quincunx and the pendulum, whose *current* state never is in the *current MB* (except for the non-evolution case). It also shows that, because the component of the *current* state along $|a\rangle$ is absorbed into heat, the output (*next*) state is $|t\rangle$, so that $\langle t|s\rangle = \cos\theta$ (**dotted black curve**) and the ratio of intensities is $\langle t|s\rangle\langle s|t\rangle = \cos^2\theta$ (**solid red curve**). The latter is known as ‘Malus Law’. Note as well that the *next* state is a ‘collapsed’ version of the *current* state. Also, because the mean value of $\cos^2\theta$ is 1/2, and **unpolarized** light is a uniform mixture of all polarization angles θ , an ideal **PF** -regardless of its orientation in space- transmits 50% and absorbs 50% of the incoming light *intensity*. The **PI** between sunlight and a **PF** is thus sui generis: it is selectively *binary* by equally distributing a multitude of input polarization directions among two privileged directions determined by the **PF**’s **MB**, of which only one goes through as light.

Remarkably, even though the *current* state of light (before the *current PI*) appears to depend on θ , it is fully determined by the *previous PI*. This is because the state -by its very ontic nature- encompasses all reactions to all possible **PIs** (all possible orientations of the milieu) and it is the expression of the state in terms of the *current MB* that makes explicit the value of θ . This angle is a property of neither light nor its milieu (**PF**) but of the spatial *relation* between them. Only after the **MB** is singled out by the milieu, the angle θ is fixed and the expansion of the *current* state in terms of the members of the **MB** is determined. Of course, any other basis for the state-space could legitimately be used, but **MB** is the one that cogently relates the theory’s *Ontology*, *Foundation*, and *Structure* – allowing for straight prediction and explanation [4]. Yet, it is unwarranted to assert that **MB** and its associated superposition are ‘physical’ or the ‘realized’ basis and superposition.

As an example, to the right of the plot, **Figure 2** depicts in dotted line a large **PF** sheet on the side of the light source (behind the page) whose optic axis is horizontal, and a smaller **PF** sheet on our side in solid line whose optic axis is vertical. Ergo, light between the **PFs** is horizontally (H) polarized and fully absorbed by the second **PF**. No light can go through two **PFs** whose optic axes are orthogonal. Formally, to find the state after the **PI** with the first **PF**, we express the input state in terms of the first **MB**, light leaving in a state along the **PF** optic eigenstate; we then express this

latter eigenstate of the first **MB** in terms of the eigenstates in the *new MB* (second **PF**), light being fully absorbed ($\cos^2 \pi/2 = 0$). But, had the angle been 45° , we would have had for the second **PF**: $|s\rangle = (\sqrt{2}/2)|t\rangle + (\sqrt{2}/2)|a\rangle$; $\vec{E}_o/\|\vec{E}_i\| = (\sqrt{2}/2)|t\rangle$; $|s_o\rangle = \vec{E}_o/\|\vec{E}_o\| = |t\rangle$; and for the ratio of intensities: $\|\vec{E}_o\|^2/\|\vec{E}_i\|^2 = 1/2$. Thus, 50% of the light would have been absorbed and 50% transmitted. Notice the crucial difference between this 50/50 behavior being only valid for $\theta = 45^\circ$, and the 50/50 behavior of **unpolarized** light occurring regardless of the **PF**'s orientation.

Below the **plot**, a third **PF** -whose optic axis is diagonal- is inserted between the previous two showing that light reappears: the 'horizontal' light out of the first 'H' filter does have a diagonal component, which goes through the interposed oblique 'D' filter. But now this diagonal component does have a 'vertical' component, which goes through the 'V' filter. From the vector diagrams, the electric fields spatially 'interfere' to produce a perplexing behavior of intensities. Let us now allow the so far 'absorbed' state $|a\rangle$ to 'show up' as light.

1.2.4.2 Beam Splitters

A beam splitter (BS) is an optical device that spatially splits each of two input high-intensity light beams into two shared output beams. In a common embodiment, two triangular glass prisms are glued together. Another variation is the so-called half-silvered mirror, a sheet of glass or plastic with a thin reflective metal coating. Again, the state in each output channel is the 'collapsed' version of the input state as spanned in the BS's **MB**, but now the two outgoing electric vectors coexist in actuality because light, as a macro-object, does split into two measurable beamlets, one in each physical channel. Depending upon the BS's type, different *phase* shifts between outputs and inputs may occur. For a lossless BS, and expanding input states $|i_1\rangle$ and $|i_2\rangle$ in the **MB** determined by the output states ($\text{MB} = \{|o_1\rangle, |o_2\rangle\}$), the following matrix equations are valid:

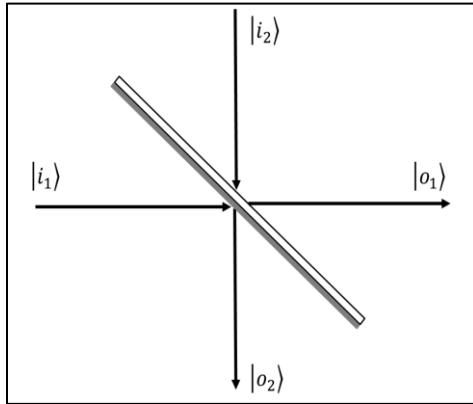

$$\begin{bmatrix} |i_1\rangle \\ |i_2\rangle \end{bmatrix} = \begin{bmatrix} t_{11}e^{i\varphi_{11}} & r_{12}e^{i\varphi_{12}} \\ r_{21}e^{i\varphi_{21}} & t_{22}e^{i\varphi_{22}} \end{bmatrix} \begin{bmatrix} |o_1\rangle \\ |o_2\rangle \end{bmatrix} = \underline{BS} \begin{bmatrix} |o_1\rangle \\ |o_2\rangle \end{bmatrix} \quad (6)$$

\Downarrow

$$\begin{bmatrix} |o_1\rangle \\ |o_2\rangle \end{bmatrix} = \begin{bmatrix} t_{11}e^{-i\varphi_{11}} & r_{21}e^{-i\varphi_{21}} \\ r_{12}e^{-i\varphi_{12}} & t_{22}e^{-i\varphi_{22}} \end{bmatrix} \begin{bmatrix} |i_1\rangle \\ |i_2\rangle \end{bmatrix} = \underline{BS}^\dagger \begin{bmatrix} |i_1\rangle \\ |i_2\rangle \end{bmatrix}$$

No bijection exists among input/output pairs because any input high-intensity beam can split, and any output beam may come from any or both input beams. However,

Equations 6, as a transformation between input and output column vectors, is *unitary* because $\underline{BS}^{-1} = \underline{BS}^\dagger$ (transpose + conjugation). But if the inputs for the *current PI* are the outputs for the *previous PI*, **Equations 6** can be viewed as a transformation between *previous* and *current MBs*.

Energy conservation and reciprocity demand: a) $t_{11} = t_{22} = T$ and $r_{12} = r_{21} = R$ for the transmission and reflection coefficients; b) $T^2 + R^2 = 1$; and c) the sum of the phase difference between the reflected and transmitted states for each input state equal to 180° , i.e. $(\varphi_{12} - \varphi_{11}) + (\varphi_{21} - \varphi_{22}) = \delta_1 + \delta_2 = \pi$ [35]. For instance, as depicted in the above diagram, per Fresnel Equations, for a mirror with a substrate of glass and a dielectric coating with a refractive index (RI) somewhere between that of glass and air, input state $|i_1\rangle$ hits the coating from air (low to high

RI) with the transmitted state $|o_1\rangle$ in phase with the input ($\varphi_{11} = 0$), and the reflected state $|o_2\rangle$ with opposite phase ($\varphi_{12} = \pi$) – making $\delta_1 = \pi$. Instead, input state $|i_2\rangle$ hits first the glass and then the coating (high to low RI) so both the transmitted state ($|o_2\rangle$) and the reflected state ($|o_1\rangle$) are in phase with the input ($\varphi_{22} = \varphi_{21} = \delta_2 = 0$) – making $\delta_1 + \delta_2 = \pi$. Such a BS is asymmetric, while a symmetric BS would have $\delta_1 = \delta_2 = \pi/2$.

1.2.4.3 Polarizing Beam Splitters

An important type of BS is the Polarizing Beam Splitter (PBS). Ideally, all the intensity of the input light is split into two output beams, each fully polarized along orthogonal directions. For a single-input PBS, as with the PF, the input field can be decomposed into two orthogonal directions (the MB determined by the PBS) so the input state is expressible as $|i\rangle = \cos\theta|o_1\rangle + \sin\theta|o_2\rangle$. The transmission and absorption axes of a PF become now transmission axis (T-axis) and deflection axis (D-axis). And, because the mean value of both \cos^2 and \sin^2 functions is 1/2, when receiving unpolarized light, 50% of a PBS' input light intensity goes through one of its outputs and the other 50% of the light goes through the other channel. Ergo, if the input light is fully polarized along the T-axis, all light is transmitted and comes out with the same polarization, with no light going through the other output. Instead, if the input is fully polarized along the D-axis, all light is deflected and comes out from the other output fully polarized along that direction. Finally, if the incoming light is polarized with say 30° relative to the T-axis, then the ratio between the magnitudes of the transmitted field and the incoming field is $\cos(30^\circ) = \sqrt{3}/2$, while the ratio for the deflected field and the incoming field is $\sin(30^\circ) = 1/2$. The sum of their squares is (ideally) unity. Polarization and physical output channel are correlated: which channel (transmitted or deflected) tells you which polarization. But, again, despite its physical significance, it is unjustifiable to affirm that the MB = $\{|o_1\rangle, |o_2\rangle\}$ and associated superposition are real: light, its states/properties, and the milieu (PBS) are the ones that are real. Bases and superpositions are abstract tools. Any other basis would (cumbersomely) do.

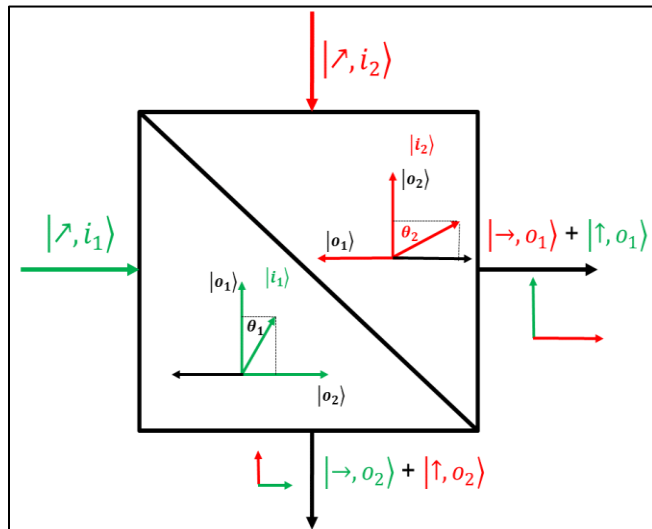

But, as shown graphically and symbolically, a PBS may have two inputs $|\nearrow, i_1\rangle$ and $|\nearrow, i_2\rangle$ with the diagonal arrow denoting arbitrary polarizations. It still has only two orthogonal axes: the T-axis and the D-axis. For any input, its polarization component along the T-axis is transmitted while the one along the D-axis is deflected. The state equations are:

$$|\nearrow, i_1\rangle = \cos\theta_1|\uparrow, o_1\rangle + \sin\theta_1|\rightarrow, o_2\rangle \quad (7)$$

$$|\nearrow, i_2\rangle = -\sin\theta_2|\rightarrow, o_1\rangle + \cos\theta_2|\uparrow, o_2\rangle$$

The angles θ_1 and θ_2 are respectively those between $|\nearrow, i_1\rangle$ and $|\nearrow, i_2\rangle$ and the T-axis. Hence, spatially orienting the PBS so that the T-axis is, say, vertical (as in the figure), for input $|\nearrow, i_1\rangle$, output channel $|o_1\rangle$ has vertical polarization (\uparrow) and output channel $|o_2\rangle$ has horizontal polarization (\rightarrow) – and vice versa for input $|\nearrow, i_2\rangle$. Notation wise, irrespectively of the spatial orientation of the PBS, we will use the diagonal

that the T-axis is, say, vertical (as in the figure), for input $|\nearrow, i_1\rangle$, output channel $|o_1\rangle$ has vertical polarization (\uparrow) and output channel $|o_2\rangle$ has horizontal polarization (\rightarrow) – and vice versa for input $|\nearrow, i_2\rangle$. Notation wise, irrespectively of the spatial orientation of the PBS, we will use the diagonal

arrow to indicate an arbitrary (in general different) polarization for the inputs, the vertical arrow to denote a polarization collinear with its T-axis, and the horizontal arrow for a polarization collinear with its D-axis. Clearly, we see that the same output channel may carry light with orthogonal polarizations from different inputs. Note that if $|\nearrow, i_1\rangle$ and $|\nearrow, i_2\rangle$ happen to be the horizontal and vertical components of a previous polarization state, then $|o_2\rangle$ reconstructs such polarization, with zero intensity for $|o_1\rangle$; and if $|i_1\rangle$ is the vertical and $|i_2\rangle$ is the horizontal component, then it is the $|o_2\rangle$ output the one with nil intensity. As shown in the figure with different colors, in the general case, both output channels carry polarized beams with components from both inputs. Once we focus on the microworld, deep understanding of how the PBS works for the single quanton is crucial for our probing and proving the ontic character of *probability* in [Section 3](#).

1.2.5 Milieu Bases for High-Intensity Electron Beams

Finally, [Figure 2](#) (bottom right) sketches the famous Stern-Gerlach (SG) experiment, which involved: 1) a vertical magnetic field increasing in intensity from the ‘N’ pole towards the ‘S’ pole but uniform otherwise; 2) a collimated horizontal beam of silver atoms traversing the field; and 3) the atoms depositing on a screen after passing the field. From the electronic shell structure of silver, its spin is due to the $\frac{1}{2}$ -spin of its outer electron [24] [3]. Based on random thermal effects in the oven producing the silver vapor, the atomic magnetic axes were assumed randomly distributed so Classical Physics predicted that the atoms would smoothly spread throughout a vertical line on the screen. Reality did not agree: instead of a vertical diffusion of the beam, two beamlets came out of the magnet with the silver atoms sharply depositing as two well-separated clusters on the screen.

In the first sketch on the [left](#), the beam (straight from the oven) comprises a uniform random distribution of spins – with two 50/50 beamlets coming out, one with spins collinear to the magnetic field, and the other anti-collinear to it. It is evident the homology with the split of **unpolarized** light along two privileged directions defined by a **PBS**. Hence, we could again define two spin eigenstates $|c\rangle$ and $|a\rangle$ representing the two privileged directions (collinear and anti-collinear) defined by the milieu (magnetic field). Note though that these two unit-vectors represent anti-collinear directions (180°), while those defined by a polarizing filter/splitter are orthogonal (90°). Hence, were $|c\rangle$ and $|a\rangle$ regular vectors in our physical space, being anti-collinear, they could not be *independent*; let alone could they be *orthogonal* in the classical sense of the word. This tells us that $|c\rangle$ and $|a\rangle$ cannot be ordinary vectors in our physical space, i.e. the state-space of the atomic beam’s spin is not a Euclidean space (as it was for the light beam’s polarization). The eigenstates are associated with the two directions of a given straight line in our local Euclidean space, but they cannot be pictured as ‘arrows’ along those opposite directions. The state-space is a 2-D Hilbert complex space and the **MB** established by the magnetic field is $\text{MB} = \{|c\rangle, |a\rangle\}$.

In the sketch on the [right](#), the SG magnet is fed with one of the two atomic beamlets obtained after the beam from the oven passed through an SG with its magnetic field horizontally oriented. The input beam has now all its atoms with the same horizontal spin, and the magnetic field is still vertical; nonetheless, the field splits the input beam again in two 50/50 beamlets along its collinear and anti-collinear directions. This is again homologous to a light beam with polarization forming an angle of 45° with one optic axis of a **PBS** and, in general, there is a partial isomorphism between the descriptions of light polarization and of $\frac{1}{2}$ -spin, provided we replace θ in the former with $\theta/2$ in the latter. We could thus express the input spin state as $|s\rangle = \cos \theta/2 |c\rangle + \sin \theta/2 |a\rangle$. Being again the mean value of $\cos^2 \theta/2$ and of $\sin^2 \theta/2$ equal to $1/2$, and being the random spin-

distribution coming out of the oven *uniform*, the 50/50 split is explained for both cases (uniform random spins and all spins orthogonal to the field). Notice that the state in each output channel is the ‘collapsed’ version of the input state as spanned in the **MB** and that, for a high-intensity beam, both states coexist in actuality because the beam, as a macro-object, does split into two measurable beamlets – one in each physical channel. Spin and output channel are correlated: which channel tells you which spin.

The **MB** is determined exclusively by the direction of the external field and not by the input beam. Even though the *current* state of the beam (before the *current* **PI**) appears to depend on θ , it is fully determined by the *previous* **PI**. Again, this is because the state -by its very ontic nature- encompasses all reactions to all possible **PIs** (all orientations of the magnet) and it is the expression of the state in terms of the **MB** that makes explicit the value of θ . This angle is a property of neither the beam nor its milieu (the magnet) but of the spatial *relation* between them. Only after the **MB** is singled out by the milieu, the angle θ is defined and the expression of the *current* state in terms of **MB** is determined. Of course, any other basis for the state-space could legitimately be used, but **MB** is the one that cogently relates the theory’s *Ontology*, *Foundation*, and *Structure* – allowing for straight prediction and explanation [4]. Again, it is unjustified to assert that the **MB** and its associated superposition are ‘physical’ or somehow ‘realized’. This is now true a fortiori, because the identification between our local Euclidean space and the spin state-space is lost.

Let me also emphasize that it is incorrect to treat these optical and magnetic **PIs** as ordinary *measurements*. They are **GIs** and no improvement whatsoever of our experimental techniques could convert them into **TMs**. The underlying physical interactions are distinctively peculiar and only when the *current* input state is in the **MB**, the **GI** is a **TM**. But, of course, we understand and characterize the **GIs** by *measuring* (in the correct sense of the word) the high-intensity light or atomic beamlets after the **PIs**. Now back to Schrödinger’s conflict as described in **SCHR3**.

1.2.6 Schrödinger’s Idea of State Fails even in the Macroworld.

Once light has passed a **PF** adopting a polarization along $|t\rangle$, of course it can be arbitrarily decomposed along any pair of non-parallel directions, so that **no** polarization along other than $|t\rangle$ is univocally determined per se. Likewise, once light has split after a **PBS**, one beam has the state $|t\rangle$ and the other $|d\rangle$. Each of the two states can be decomposed at will along any pair of non-parallel directions, so that **no** polarization property other than the one each channel has is univocally determined per se. As for the atomic beam, once it has split after the SG magnet, one beamlet has the state $|c\rangle$ and the other $|a\rangle$. Again, each state can be decomposed along any pair of independent spin states, but **no** spin property other than the one each channel has is univocally determined per se.

We conclude that what Schrödinger called “the classical concept of state” in **SCHR3** is not valid for polarization/spin of macro-objects like high-intensity light/electron beams. Thus, even at our common level of experience, his classical concept of state may “become lost” because there is no “complete set of properties” to which “definite numerical values can be assigned” without conflict. Furthermore, two milieus involving, say, **PFs** with different optical axes or SG magnets along different directions are clearly epistemically incompatible, i.e. we cannot arrange for a beam of light/atoms to interact with both milieus at once. Nonetheless, the state of the light and atomic beams does encompass their response to all possible milieus. And notice that we have not yet made use of the notion of *probability* at all. Time to go down to the single quanton.

1.2.7 Dimming Intensity down to a Single Quanton

We can go from the macroworld down to the microcosm by reducing the intensity of a monochromatic light, i.e. by decreasing the trillions upon trillions of *photons* per second until we start ‘seeing’ individual photons scintillating on a fluorescent screen, say, once every 10 seconds. This latter sparkling frequency has nothing to do with the frequency of the light source and all to do with its faint intensity. The radiation source’s *frequency* was not modified and that is why we can sensibly talk about the *frequency* f of a single photon and its energy $E = hf$. Likewise for its *wavenumber* \vec{k} and momentum $\vec{p} = \hbar\vec{k}$, though the latter depend on the medium (milieu) via the propagation velocity (which may also depend on the frequency).

Louis de Broglie initially conjectured that when two intensity-dimmed monochromatic waves were *superposed*, the single photon would have energy and momentum somewhere between those of the two waves. However, he soon admitted that the very photoelectric effect proved that Born’s Rule, *not* his, was the correct one: when the two monochromatic waves (both of sufficiently high frequencies f_1 and f_2) hit a metal plate, only electrons of either energy hf_1 or energy hf_2 were ejected. Furthermore, when the f_1 -wave was twice as intense as the f_2 -wave, then twice as many electrons were ejected with energy hf_1 as those with energy hf_2 [24] [3].

From above and the known relation between high-intensity light and its electric field, the number density of photons on a screen spot must be proportional to the squared amplitude of the electric field. Ergo, for the *single* photon case, a ‘probability amplitude’ can be defined as a complex number the squared modulus of which gives the *probability* of its landing on such spot, and whose *phase* depends on the frequency of the photon’s source, the propagation speed, and the covered distance. This is nothing but the mystically revered Born’s Rule. In this fashion, the so-conceived micro-phenomenon of quantic interference becomes responsible for, and consistent with, the well-known macro-phenomenon of high-intensity interference. Likewise for the *coherence* feature of a high-intensity light wave whose analog in the microworld is the *phase coherence* of the photon’s quantic state. More about this in Part IV [1].

For instance, being sunlight unpolarized, we can say that any of its photons has a 50% probability of passing through a linear PF regardless of its spatial orientation, and that number is a collective property of an ensemble of photons with a uniform distribution of all possible linear polarizations. Any use of probability in such a case is *epistemic*. However, if after dimming sunlight to a single photon at a time passing through a PF, we fed it to a second PF at 45° with the first, we would again find that 50% of the photons (all entering now the second PF with the same polarization) are transmitted and 50% are absorbed – which prevents us from attributing such statistics to the ensemble, while forcing us instead to ontically assign the 50/50 *chance* to each individual quanton/milieu. This *probability* clearly depends upon the initial polarization state of the photon relative to the milieu (θ), with the Mean for the polarization property equal to $+1\cos^2(\theta) - 1\sin^2(\theta) = \cos 2\theta$ [3].

The same rationale is valid to assign *probability amplitudes* and *phase* to an electron. For instance, based on the mean of $\cos^2(\theta/2)$ over θ , we explained the statistical 50/50 distribution we found for the **atomic beam** coming out of the oven. However, such average over the angles must not be confused with the mean of the spin property as a random variable for a single electron: if we dimmed the atomic beam intensity so that a single atom traversed the magnetic field at a time, we could not say that each atom had an ontic probability of 0.5 to go up and of 0.5 to go

down. The 50/50 split was a *collective* property of the ensemble, not of each atom in the beam. If so used, the *probability* in such a case is *epistemic*. But feeding the vertical magnet with atoms *all* coming *one by one* from a previous horizontally oriented magnet ($\theta = \pi/2$), we still found a 50/50 split – which prevents us from attributing such statistics to the ensemble, while steering us instead to ontically assign the *probability* to each individual quanton/milieu. This ontic probability clearly depends upon the initial spin state of the atom relative to the field, and the Mean for the spin property is $+1\cos^2(\theta/2) - 1\sin^2(\theta/2) = \cos\theta$ [3].

Strikingly, we find that the same **MB** determined by the milieu (polarizer, splitter, magnetic field, etc.) we used to mathematically represent macro-objects like high-intensity light or electron beams serves also as the **MB** for the state-space of a *single* quanton’s polarization or spin. The milieu (a macro-object) top-down influences the quanton by defining its *probable* next states, and the quanton’s current state bottom-up influences the milieu: upon a **GI**, there is a correlation between the quanton’s post-**GI** state and the milieu’s post-**GI** macrostate (the result of the so-called ‘measurement’) [3] [4] [5].

Once a photon/electron undergoes a **GI** adopting a polarization/spin eigenstate in the **MB**, of course, such state can be decomposed at will along any other set of independent polarization/spin states, but **no** polarization/spin property other than the one it has can be univocally assigned to the acquired state. Schrödinger was right in **SCHR3**: “The classical concept of state becomes lost” because there is no “complete set of properties” to which “definite numerical values can be assigned”. Attempting to do so, a “conflict with some portion of quantum theoretical assertions” would certainly be in place. Yet, he was wrong because, as we proved, the macroworld versions of photons and electrons (high-intensity beams) already had this widely unnoticed ‘**unclassical**’ feature for their states. In **QT** parlance, for swarms of independent photons and electrons, the Hamiltonian Operator for the composite wavefunction is the sum of the individual Hamiltonians and -from the solution of **Schrödinger’s Equation**- the *wavefunction* for the platoon of quantons is the product of the individual *wavefunctions*. Hence, in these special cases, the *wavefunction* of a single quanton is a bona fide representative of the squad, and the much-higher-dimension *Configuration space* could be conceptually reduced to our 3D physical space – justifying the early futile attempts to consider the *wavefunction* as a real classical wave [36].

We have shown, via the ontic probability interpretation of scaled-down high-intensity light and atomic beams, that the ontic state of a *single* quanton can be conceived so that predictions accurately agree with experiment, while correctly scaling-up to our common level of experience. In fact, we devised the single quanton’s state from the collective state of platoons of quantons, so no wonder the concept still is valid for high-intensity beams. But, in the process of developing **QT**, its pioneers were bound to find in the microworld behaviors even stranger than the ones we scaled-down from high-intensity light and atomic beams and, falsely assuming that *reductionism* implies straightforward *constructionism*, some philosophers/scientists -infatuated with linearity and **Schrödinger’s Equation**- staunchly expected that the description/explanation of those sui generis micro-phenomena had to scale-up to the macroworld without exception. Others, knowing such scale-up was invalid, tried desperately to -paraphrasing Feynman [34]- conceive quantumlike “wheels and gears” processes to explain the difference. We thus fell in the trap of century-long mostly misguided philosophical discussions on the link between the micro and macro worlds.

2. TOPI: The Quanton's Ontic State/Properties and Physical Interactions

QT/TOPI is a metatheory: a theory about the meaning of Quantum Theory. To deeply dive into the heart of QT/TOPI -when unambiguous- we will not explicitly distinguish between *abstract* states/properties (*Foundation*) and *real* states/properties (*Ontology*) [4]. TOPI agrees with Einstein in that “there is something like the ‘real state’ of a physical system, which independent of any observation or measurement exists objectively and which can in principle be described by means of physical terms” [2]. QT/TOPI disagrees with Einstein and Schrödinger in that the stochastic makeup and “spooky action at a distance” of QT imply its *incompleteness*. In fact, we will argue in Part IV [1] that it is Einstein’s RT the one *incomplete*. It is ironic that, using EPR’s own necessary condition for completeness [2] [4], if RT forbids *nonlocality* (amply confirmed over four decades unless we embrace retrocausality/superdeterminism [37] [38] [39]), then RT must be *incomplete*. Saying that what RT only forbids is faster-than-light *signaling* amounts to another strawman argument: Reality is that unless we allow for *exotic* causal structures, direct *spacelike* interactions do take place in our Universe – and RT neither allows for the *former* nor includes in its *Ontology* (let alone predicts) the *latter* [1] [40] [41] [5].

From Part I [4] and Part II [5], a quanton interacts with its *milieu* and has: (a) the *ontic current* state/properties attained from the *previous PI*; and (b) the *ontic current PD* for the transition to its *next* states/properties. The *next* state and *next* properties are *random* variables. The *current* state belongs to the *MB* for the *previous PI*. All probable *next* states belong to the *MB* for the *current PI*. We refer to them as *previous MB* and *current MB*. The so-called *pure* state $|s\rangle$ of an *isolated* quanton is represented in QT by a unit-vector in Hilbert Space, i.e. a complex vector whose 2-norm $(+\sqrt{\langle s|s\rangle})$ is unity. A *pure* state is expressible in any orthonormal basis for the state-space as a *2-superposition* of eigenstates, i.e. the sum of the squared moduli of its coefficients is unity.

We will say that a state, property, PD, etc. are determined when a) they are defined, i.e. they have physical meaning; and b) they have definite values. By a ‘definite value’ I mean much more than the “definite numerical value” requested by EPR [2] and Schrödinger in SCHR3: I mean a number, a function, a vector, an operator, whatnot – depending upon the nature of the physical magnitude and its possibility space. The quanton’s *current* state is always determined; *not* all the quanton’s properties are defined in the *current* state; the *current* state and values for all its defined properties are determined (stochastically) by the *previous PI*; the *current MB* is determined by the *current* milieu (PI); the transition PD for the *next* states is jointly determined by the *current* state and *current MB*; only those properties whose operators share their eigenvectors in the *current MB* (commutative operators) are determined as *next* properties, with their common transition PD determined by the *current* state and the corresponding operator.

The *ontic current* state encompasses the quanton’s reaction to all possible milieus and because each milieu defines an *MB*, the *current* state encompasses all possible state-transition PDs. Ergo, all *next* states are defined but may be *undetermined*: it is the milieu (PI) that determines which the *next* probable states are (elements of *MB*). As for the properties, depending on both *previous* and *current MBs*, a property which is defined/undefined for the *current* state can be undefined/defined for the *next* states. Different milieus (different PIs) entail different *MBs* but the reality of the quanton state is prior to, and independent of, any future PI. The *physical* state is non-contextual simply because it includes all possible contexts; its mathematical representation using the *MB* is the one that is different for each context (milieu). The distinction between the all-encompassing

ontic state and its specific (partial) *mathematical depiction* should be kept in mind. **TOPI** asserts that *current* and *next* states are all ontic (irrespective of our existence and knowledge), while their symbolic representations are *epistemic*. This is not incompatible with the impossibility of globally assigning “**definite numerical values**” to all properties for a given state [25] [26] [27].

The quanton’s state is ontic but not a beable (in Bell’s sense of the word [42]); our quanton is the beable though -unlike Bell’s- it can display *local* as well as *nonlocal* behaviors [5] [3]. And being the *current state* all-inclusive, all *next states* in all possible **MBs** and all state-transition **PDs** are (paraphrasing **SCHR3**) “determining parts” of the *current state* and, ergo, ontic as well. But, despite its ontic comprehensive character, in *our* attempts to formally depict the state, our mathematical treatment is necessarily limited to specific aspects of the full state/properties, e.g. the *polarization state* of a photon (**Figure 2/top-right**) or the *spin state* of a two-electron quanton (**Figure 3**). In such cases, the state encompasses all possible milieus relevant to either *polarization* (e.g. all **PF**’s orientations) or *spin* (e.g. all spatial orientations of two SG magnets). All other categories of states and properties the quanton may have or milieus may encounter, though still part of the ontic state, are unnecessary for understanding/predicting the quanton’s behavior under those circumstances. Again, Reality and its mathematical representation are different animals.

2.1 Actual States and Probable States

To be real in Classical Physics, all states and properties had to be/become actual, viz: they had to be, could have been, or could be observed and/or measured in our **RT**’s spacetime. Contrariwise, under **QT/TOPI**, *probability* is the hallmark of Nature’s modus operandi: there is a point at which, between *current* and *next* states, “there are no wheels and gears” in spacetime [34]. Previous, current, and next states can be *actual* or *probable*, with the latter as *real* as, and more fundamental than, the former. Moreover, the *actual* is the unsubtle manifestation of the *probable*: there is more in this Universe of ours than what we can directly observe/measure. Observation and measurement are anthropic: the Universe is out there with or without our cognitive endeavors. The *actual* relative frequency of an *event* in our **RT**-spacetime, obtained via the statistical analysis of multiple experimental runs, is only one (direct) manifestation of the *ontic* character of probability, assisting us in validating its *reality* [18] [19] [3]. We will soon see other much subtler manifestations.

When I say a *current* state/attribute is ‘probable’ I do not mean that it is ‘actual’ though we do not *know* its value (**EPR**’s Conceptual Confusion [4]); that would be the *epistemic* meaning of probability. Neither do I simply mean that it may *become* actual in the future. What I mean is that the *current* state/property *is* one of the probable states/properties for the quanton’s *previous PI*. Notice I said: “it *is* one of the probable states...”, not “it *was* one of the probable states...”. Only when it is *actual*, the *current* state *was* probable for some previous **PI**; otherwise, it *is* probable. Again, probable states/properties and actual states/properties are equally *real* under **TOPI**.

Being probable and actual states equally *real*, the former can evolve, interact, and transform as the latter do. And being the state *ontic*, the **PD** determined jointly with the **MB** is also *ontic* regardless of whether the transition to an actual state occurs or not. When the actual transition occurs, because actual states may directly manifest in **RT**-spacetime, only *one* of the *next* states in the **PD** becomes actual. Otherwise, all *next* states are probable, irrespective of whether the *current* state is actual or probable. Furthermore, because a quanton has no size or shape, its milieu may be a spatially extended network of localized **PIs** whose events may be spacelike-separated in our **RT**-

spacetime. Ergo, stunningly against our prejudices, the co-extant probable states of a single quanton may undergo different **PIs** (with different **MBs**) at different locations in the network.

From above, the qualifiers ‘previous’, ‘current’, and ‘next’ applied to **PIs**, states, properties, and **MBs** have a significance that transcends our classical notion of *time*. In **RT**, *time* (**R-Time**) is operationally defined and, thus, it can only be cogently assigned to *actual* (**not probable**) states. Hence, only for actual states/properties, the adjectives ‘previous’, ‘current’, and ‘next’ have the meaning with respect to *time* that we accept in our common level of experience. That is not the case for probable states which can correlate to extended regions of **RT**-spacetime so, until we fully tackle the **incompleteness** of **RT** and **QT** in Part IV [1], when our discourse calls for assigning a ‘time’ to a probable state, I will use the idiom ‘**QR-Time**’. Notice that I am not implying there are two different types of *time*; I am implying that **RT** and **QT** are **incomplete**, and the notion of *time* should be reconceived so that what I call now ‘**QR-Time**’ as a mere *faute de mieux* would be fully integrated into a revised embracing theory (to be called **QR/TOPI**). Thus, to be able to proceed, we must also tighten the semantics behind words that normally refer indifferently to *space* or to *time*: we convene in that the terms ‘first’, ‘intermediate’, ‘last’, ‘input’, ‘before’, ‘output’, ‘after’, ‘serial’, and ‘parallel’ refer **only** to the topology³ of **PIs** in our physical *space* (not to **R-Time**).

Hence, the words ‘previous’, ‘current’, and ‘next’, may refer to **R-Time** (if *actual* states are involved) or to **QR-Time** (if probable states are at play). The *current* state is the joint (stochastic) result of the *previous* state and *previous MB*, while the *current MB* and *current* state jointly determine the **PD** for the *next* states and properties. A quanton’s *current* state is probable or actual because of a *previous PI* – but such character is irrelevant for the *current PI*. If the quanton’s *current* state is probable/actual, so are its *current* (those defined) properties. **No actual** transition is necessarily implied by the *current* state and its milieu, so all *next* states/properties are *prima facie* probable – except when the *current* state is in the *current MB*, in which case the **SD** of the **PD** vanishes and, for an actual current state, the *next* state is also actual. When *current* and *next* states are all probable, **no** different **R-Times** can be assigned to them.

For instance, after a ½-spin quanton went through a Stern-Gerlach (SG) setup (**Figure 2**, bottom right), if detected, its spin would be +1 if it came out collinear with the magnetic field and –1 if it came out anti-collinear with the field [5]. If the *current* state entering the SG milieu is actual, both *next probable* states are determined by the milieu via an actual PD. Instead, the *next* spin along any other direction than those two in the **MB** is *defined* but **undetermined**. If each one of the two physical output channels is (without detection) connected to a different SG magnet, the probable state correlated with each channel plus the new **MB** determine a new probable PD for the *next probable* states in each channel. Note that, because each of the output states from the first SG magnet is probable, the **PD** for each of the two SG subsequent magnets is probable as well. Even **PDs** can be actual or probable. In both cases they are determined.

2.2 Probability Invariance buried in an Infinitude of Symbolic Depictions

Under **QT/TOPI**, the **MB** plays a preferred role but only epistemically – and the interwoven ontic and epistemic reasons have been explained via multiple concrete **examples** in both the macro and the micro worlds. The **MB** is *special* because: a) its elements are the possible *next* states; and

³ By ‘topology’ we mean the connectedness structure among the **PIs** (which outputs go to which inputs) plus the spatial extension of those links (providing a phase factor to the probable state associated with each of them).

b) using the **MB** to expand the *current* state (if *pure*), the coefficients of the 2-superposition are the **probability-amplitudes**, whose squared moduli make up the **PD** for the *next* states of the quanton.

Calling \underline{s}_m the column vector for the ontic state $|s\rangle$ spanned in the **MB** = $\{|m_j\rangle\}$, and \underline{s}_a the column vector for the same state spanned in **any** basis **AB** = $\{|a_j\rangle\}$, they are related as follows:

$$\underline{s}_m = \underline{M}_a^\dagger \underline{s}_a = \underline{A}_m \underline{s}_a \Leftrightarrow \underline{s}_a = \underline{A}_m^\dagger \underline{s}_m = \underline{M}_a \underline{s}_m \Rightarrow (\underline{M}_a)_{ij} = \langle a_i | m_j \rangle ; (\underline{A}_m)_{ij} = \langle m_i | a_j \rangle \quad (8)$$

Where \underline{M}_a is a unitary matrix, whose columns are the components of the eigenstates in **MB** when spanned in terms of the eigenstates in **AB**; and mutatis mutandis for \underline{A}_m . This is also valid for continuous physical states/attributes. For instance, via the bijections $\{|a_j\rangle\} \leftrightarrow \{|q\rangle\}$ (position basis) and $\{|m_j\rangle\} \leftrightarrow \{|p\rangle\}$ (momentum basis), we obtain the following correspondences:

$$\begin{aligned} (\underline{M}_a)_{ij} = \langle a_i | m_j \rangle &\Leftrightarrow \langle q | p \rangle = \frac{1}{\sqrt{2\pi}} e^{ipq/\hbar} ; (\underline{A}_m)_{ij} = \langle m_i | a_j \rangle \Leftrightarrow \langle p | q \rangle = \frac{1}{\sqrt{2\pi}} e^{-ipq/\hbar} \\ \underline{s}_m = \underline{M}_a^\dagger \underline{s}_a = \underline{A}_m \underline{s}_a &\Leftrightarrow \langle p | s \rangle = \frac{1}{\sqrt{2\pi}} \int_{-\infty}^{+\infty} e^{-ipq/\hbar} \langle q | s \rangle dq \\ \underline{s}_a = \underline{A}_m^\dagger \underline{s}_m = \underline{M}_a \underline{s}_m &\Leftrightarrow \langle q | s \rangle = \frac{1}{\sqrt{2\pi}} \int_{-\infty}^{+\infty} e^{ipq/\hbar} \langle p | s \rangle dp \end{aligned} \quad (9)$$

We see that the momentum eigenstates projected onto the position eigenstates ($\langle q | p \rangle$) are the elements of an infinite continuous matrix. Likewise for the position eigenstates projected onto momentum eigenstates ($\langle p | q \rangle$). Clearly, the two infinite continuous matrices are Hermitian conjugates as are their discrete versions. The second line (right) of **Equations 9** relates the projection of any ontic state $|s\rangle$ onto the momentum eigenstates ($\langle p | s \rangle$) as a superposition of the projections of the same ontic state onto the position eigenstates ($\langle q | s \rangle$). Mutatis mutandis for the third line. Clearly, the position and momentum bases are interchangeable despite that, for a particular **PI**, only one of them can be the **MB** (their operators do not commute).

Any two bases are thus related via a unitary transformation, so all bases are equally valid to depict any ontic state. Also, because only moduli and relative phases of the *probability-amplitudes* have physical significance, multiplying them by a *common* phase factor ($e^{i\delta}$, δ real) changes nothing [3]. Therefore, we conclude that an ontic state has an infinitude of symbolic depictions: (a) one for each of the continuum of bases in the quanton's state-space; and (b) for each of those bases, one for each of the continuum of phase factors. The case (a) is archetypical of theories whose *Structure* [4] includes vector spaces, and proves that the *ontic* state includes all quanton's reactions to a class of **PIs** (one for each **MB**). The case (b) is common among mathematical tools (**QT's Structure** [4]): they may represent more than what is physically meaningful.

Being all bases equivalent, for a *current* state and milieu, the state-transition **PD** must be an *invariant* under changes of the basis used to represent the state in each frame and, as it will be discussed in Part IV, also under changes of the inertial frame [1]. Because the **MB** is the set of

eigenvectors for any property's operator \mathcal{P} associated with the milieu, whether the chosen basis is **MB** or not, the Mean of the property's **PD** is the inner product of the *current* state $|s\rangle$ with its *image* via \mathcal{P} ; likewise, the square of the **SD** is the inner product of the *current* state with its *image* via the square of the Mean-shifted operator [3]; and so forth for all moments of the **PD**. Equivalent basis-independent statements can be made for all **PD**'s moments using the 'trace' (tr) operation, the density operator (ρ), and the property operator (\mathcal{P}). In symbols for the first two moments:

$$\langle \mathcal{P} \rangle_{|s\rangle} = \langle s | \mathcal{P} | s \rangle = tr\{\rho \mathcal{P}\} \quad ; \quad \Delta \mathcal{P}_{|s\rangle}^2 = \langle s | \{\mathcal{P} - \langle \mathcal{P} \rangle J\}^2 | s \rangle = tr\{\rho \{\mathcal{P} - \langle \mathcal{P} \rangle J\}^2\} \dots \quad (10)$$

Because inner product and trace operation are invariant under a change of basis, for the *current* state and milieu, the state-transition **PD** is invariant and the quanton's properties are split in two groups: those whose transition **PDs** are determined and those which are defined but undetermined. Any two operators (properties) inside the first group are commutative (same **MB**), and any two operators from different groups are noncommutative. Properties in the first group share the same **PD**: the state-transition **PD** from the current state to the eigenstates in the common **MB**. The milieus for two noncommutative operators are *epistemically incompatible*, i.e. *we* cannot arrange for the quanton to jointly interact with both milieus (**PIs**). Yet, they are *ontically consistent* because all milieus (all **MBs**, and all **PDs**) are defined and encompassed by the quanton's *ontic* state.

Succinctly: the *real* state (actual or probable) comprises all its depictions, one for each **MB** in a multitude of **PIs** (milieus). It encapsulates all possible behaviors of the quanton when interacting with such a large class of milieus. Given the ontic state and a **PI**, all bases are valid – but Born's rule is applicable as such only to the **MB** determined by the **PI**. Using any other basis is equally legitimate, though it requires a basis transformation (Equations 9) before applying Born's Rule.

2.3 Mixed States, Convex States, Pure States, and Co-States

As said, *pure* states are represented by unit-vectors in Hilbert Space and correspond to isolated quantons. The states/properties of different (with no common history) isolated quantons are of course uncorrelated and, if they are viewed as a composite quanton, then it is said that the latter is in a *product* state because it can be expressed as the *product* of the sub-quantons' *pure* states. But, in general, sub-quantons of a composite quanton do interact and -depending upon the global milieu- their behavior may be correlated to various degrees. We say the sub-quantons are *entangled*, and the composite state is an *entangler* state. Despite being *entangled* (i.e. not isolated), the sub-quantons' behavior may be uncorrelated for some milieu(s), in which case the composite state is again expressible as a product. 'Entangled' and 'correlated' are not synonyms; 'not correlated' and 'isolated' are not synonyms either. 'Entangled' and 'isolated' are antonyms.

As any state, the entangler state is ontic, probabilistically determined by the *previous* **PI**, and governs jointly with the *current* **PI** (milieu) how much correlation the sub-quantons display – from non-correlation through maximal correlation. The sub-quantons' states cannot be represented by a *unit* vector in their individual state-spaces because entangled quantons lose their *isolation*. We say that entangled sub-quantons are in *co-states* though, in the literature, are called 'mixed states'. The 'mixed' adjective was chosen because their mathematical depiction is like the one for the mixed state of some macro-objects as explained in Section 1.2 (e.g. sunlight). Yet, they are utterly different because the latter mixed state characterizes *not* a single quanton but an *ensemble* of quantons with unknown *pure* states. Even when dealing with a single quanton, if we do not know

its pure state, we may epistemically resort to represent it through a probabilistic mixture (**convex superposition**) of *pure* states. In those cases *probability* has, for each quanton, the classical ‘ignorance’ meaning, i.e. Schrödinger’s “**merely not exactly known to me**”. It is also the tenet of the Statistical Interpretation of QT [43], which claims that QT describes only *ensembles*, to wit, that it is a kind of *quantum* statistical mechanics. **TOPI** categorically rejects such a stance.

Because sub-quantons are as real as the composite quanton, their *co-states* are as ontic as the composite’s *pure* state. But despite their core differences, **convex states**, mixed states, and *co-states* are all representable by **1-superpositions** (*not* by 2-superpositions). A central difference between the **Quincunx** ball’s *convex* state and the *co-state* of a sub-quanton in a *pure* composite quanton is that, upon a **GI**, the former adopts another *convex* state, while the latter switches to a *pure* state. An interesting finding, vital to understand **Schrödinger’s hellish machine**, is that the state of a **radioactive nucleus** cannot be represented by a 2-superposition either (i.e. such a state is, against conventional wisdom, not pure but *convex*). In sum, mixed states are epistemic; convex, pure, and *co-states* are ontic. Notice that a pure state can be seen as a 1-superposition (i.e. convex) of only one term (itself) with unity coefficient.

For a local **PI** (on one of the sub-quantons), the composite state determines the state-transition **PD** towards the eigenstates in the local **MB**. This local **PD** is as ontic as the **PD** for a global (both sub-quantons) **PI** is. But, not being *pure*, a *co-state* does not belong to any local **MB**, i.e. it is not an eigenstate for any local **PI** and, ergo, no **GI** can be a **TM** (no **PD** has a nil **SD**). Born’s Rule does not rule; **no 2-superposition** is possible, except for those global milieus for which the two sub-quantons are **uncorrelated** (despite being entangled). The *pure* eigenstates the sub-quantons could have been in before getting entangled are **inaccessible** until detangling.

Because a *co-state* is not a state of a sub-quanton but a mutual state between two or more sub-quantons, they are all probable, though they never become actual as such. Upon a local **GI** on **one** of the sub-quantons, they detangle with their *co-states* morphing into isolated (though related) actual pure states – and the composite *entangler* state becoming an actual product state [5] [3]. Let us exemplify *pure* states and *co-states* with the famous **EPRB** experiment.

2.3.1 EPRB Instantiation of Pure States and Co-States

In the **EPRB** setup (**Figure 3**), from Part II [5], the composite state can be expressed:

$$|s\rangle = \frac{\sqrt{2}}{2} \sin\left(\frac{\theta}{2}\right) |s_{A1}\rangle |s_{B1}\rangle + \frac{\sqrt{2}}{2} \cos\left(\frac{\theta}{2}\right) |s_{A1}\rangle |s_{B2}\rangle - \frac{\sqrt{2}}{2} \cos\left(\frac{\theta}{2}\right) |s_{A2}\rangle |s_{B1}\rangle - \frac{\sqrt{2}}{2} \sin\left(\frac{\theta}{2}\right) |s_{A2}\rangle |s_{B2}\rangle$$

↓

$$Pr(|s_{A1}\rangle |s_{B1}\rangle) = Pr(|s_{A2}\rangle |s_{B2}\rangle) = \frac{1}{2} \sin^2\left(\frac{\theta}{2}\right) ; Pr(|s_{A1}\rangle |s_{B2}\rangle) = Pr(|s_{A2}\rangle |s_{B1}\rangle) = \frac{1}{2} \cos^2\left(\frac{\theta}{2}\right)$$

↓

(11)

$$Pr(|s_{A1}\rangle) = Pr(|s_{A1}\rangle |s_{B1}\rangle) + Pr(|s_{A1}\rangle |s_{B2}\rangle) = Pr(|s_{A2}\rangle) = Pr(|s_{A2}\rangle |s_{B1}\rangle) + Pr(|s_{A2}\rangle |s_{B2}\rangle) = 1/2$$

$$Pr(|s_{B1}\rangle) = Pr(|s_{A1}\rangle |s_{B1}\rangle) + Pr(|s_{A2}\rangle |s_{B1}\rangle) = Pr(|s_{B2}\rangle) = Pr(|s_{A1}\rangle |s_{B2}\rangle) + Pr(|s_{A2}\rangle |s_{B2}\rangle) = 1/2$$

↓

$$[\mathcal{P}_A, \mathcal{P}_B] = 0 \quad ; \quad \langle \mathcal{P}_A \rangle = \langle \mathcal{P}_B \rangle = 0 \quad ; \quad \Delta \mathcal{P}_A = \Delta \mathcal{P}_B = 1 \forall \theta$$

$$\text{Corr} = \frac{\langle \mathcal{P}_A \mathcal{P}_B \rangle - \langle \mathcal{P}_A \rangle \langle \mathcal{P}_B \rangle}{\Delta \mathcal{P}_A \Delta \mathcal{P}_B} = \langle \mathcal{P}_A \mathcal{P}_B \rangle = -\cos\theta \quad ; \quad \Delta\{\mathcal{P}_A \mathcal{P}_B\} = |\sin\theta|$$

Evidently, the sub-quantons are *entangled* because the probability for each composite eigenstate (pair of remote eigen-spins) is *not* the product of their local probabilities (1/4). Also, as fully argued in Part IV [1], it proves that **QT** is *not locally* causal per Bell's definition – with no need to point out the violation of his famous inequality. Even so, per lines 3 and 4 of **Equations 11**, the *local* spins are perfectly *random* for *any* local and remote magnet orientations. The local **MB** contains the probable next pure states, but their transition **PD** (50/50) is independent of local and remote **MB**s. As explained, co-states are not pure states.

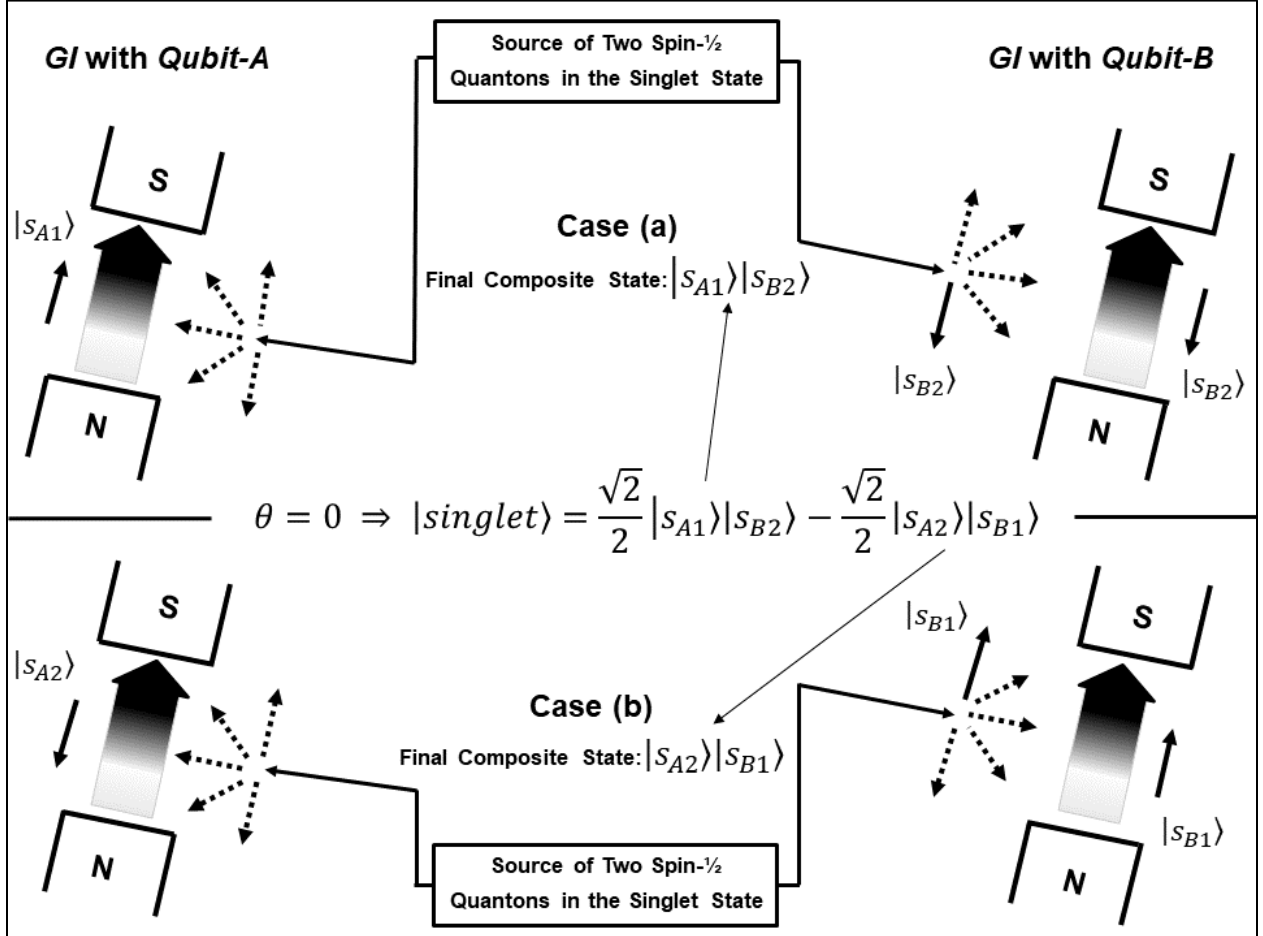

Figure 3: Upon a local GI, Co-States morph into Actual isolated Pure States

If we wanted to express the state of qubit-A as pure, it could be: $|s_A\rangle = \sqrt{2}/2 (|s_{A1}\rangle \pm e^{i\theta} |s_{A2}\rangle)$; likewise for qubit-B: $|s_B\rangle = \sqrt{2}/2 (|s_{B1}\rangle \pm e^{i\theta} |s_{B2}\rangle)$ ⁴ with $\theta = \theta_A - \theta_B$. In both cases the 2-norm is unity and the **PD** is 50/50 – regardless of their local magnet's orientation and their mutual angle θ . But we prove in the **Appendix** that the composite state $|s\rangle$ can be made equal to the product of two pure states only for $\theta = \pi/2; 3\pi/2$ – constraining the values of θ_A and θ_B . Clearly,

⁴ For the photon, they correspond to *linear* polarization for $\theta = 0$; *circular* for $\theta = \pi/2$; and *elliptical* otherwise [3].

the sub-qubits cannot be in *pure* states: a *pure ontic* state $|s_A\rangle(|s_B\rangle)$ must encompass all possible milieus $\theta_A(\theta_B)$, and **no** 2-superposition can accomplish that when the sub-quantons are entangled.

Because, per **TOPI**, *probable* states are as real as *actual* states, the condition in a conditional probability can be an *actual* or a *probable* state. We can therefore affirm from **Equations 11**:

$$Pr(|s_{B1}\rangle/|s_{A1}\rangle) = Pr(|s_{A1}\rangle/|s_{B1}\rangle) = Pr(|s_{B2}\rangle/|s_{A2}\rangle) = Pr(|s_{A2}\rangle/|s_{B2}\rangle) = \sin^2(\theta/2) \quad (12)$$

$$Pr(|s_{B2}\rangle/|s_{A1}\rangle) = Pr(|s_{A1}\rangle/|s_{B2}\rangle) = Pr(|s_{B1}\rangle/|s_{A2}\rangle) = Pr(|s_{A2}\rangle/|s_{B1}\rangle) = \cos^2(\theta/2)$$

Equations 12 clearly show the entanglement between the two qubits because their probabilities are mutually interdependent through θ , which is a joint property of both local milieus. They also tell us what would happen if one of the qubits underwent a **GI**: a) the one that did would adopt one of the eigenstates in its **GI**'s **MB** becoming a pure actual state and, ergo, detangling from the other qubit; and b) the probability for the other qubit to transition (upon a future **GI**) to one of the eigenstates in its **GI**'s **MB** would not be 50% anymore because **Equations 12** include θ and correspond to the behavior of an *isolated* qubit when the angle between its spin and the magnetic field is $\theta + \pi$. This proves the two qubits are **detangled**, and the opposite of the actual state adopted by the one that underwent the first **GI** is *teleported* to the other, which is the actualization of an already existing reciprocal tele-interaction between the local **MBs** (**Equations 12**). And, as it will be explained below and in greater detail in Part IV [1], this actual teleportation of the opposite state occurs even if the other qubit never undergoes a **GI**. Thus, if the other qubit interacts with a magnetic field collinear or anti-collinear to the one with which the first qubit interacted, its pre-**GI** state is an eigenstate of the local **MB** and its post-**GI** state is the same, i.e. the **GI** is a **TM**. This was the heart of the unsuccessful stratagem employed by **EPR** to prove **QT** incomplete [4] [5].

Remarkably -whether the qubits are spacelike-separated or not- it is immaterial which one undergoes a **GI** first, even though -before their **GIs**- the first qubit would have been in a *co-state* (whose **PD** does not depend upon the local milieu) and the second one in a *pure* state (whose **PD** depends upon the local milieu). This clearly is not a dynamic causal relation in **RT**-spacetime. Epistemically, were we to conduct many experiments under the same arbitrary θ , both sites would see a dull (50/50) sequence of $+1/-1$ (same **PD**) regardless of the actual orientation of each local magnet and of which **GI** is first (**Equations 11**/lines 3 and 4). However, if for each θ , upon getting together, the results in one site were grouped in subsets that corresponded to a given result in the other site, each experimenter would find a **PD** per **Equations 12** – again regardless of which **GI** was the first. So, at least in this respect, **QT** is compatible with **RT** because -for spacelike events- ‘the first’ in one inertial frame could be ‘the second’ in another. Further, we will see in Part IV [1] that the **PD** is *invariant* under a change of inertial frame. However, due to the spacelike interaction between the sub-quantons, Lorentz-Invariance is clearly violated. Compatibility of **QT** with **RT** is the subject of Part IV [1].

Applying the Density Operator formalism, the **EPRB** experiment is carefully dissected from the **TOPI** perspective in the **Appendix**, clearly showing the sub-quantons can be uncorrelated not because they are isolated but because they are entangled while interacting with a unique global milieu. All the richly intertwined described behavior is displayed by the global attribute $\mathcal{P}_A\mathcal{P}_B$, while the local (commutative) properties \mathcal{P}_A and \mathcal{P}_B are fully random for any possible orientation of the magnets. As we saw, changing the magnets configuration does not stop the local spin records

from being an amorphous sequence of $+1s$ and $-1s$; only their product shows an abundance of statistical patterns, for the recognition of which the two experimenters need to compare their records by human communication. Failing to do that, in a very peculiar way, the two subsystems are *entangled* but *disconnected*.

Ironically, this seemingly mesmeric interaction among sub-quantons could accurately describe the legendary Bohr/Einstein debate: had they known/understood that such an astonishing nonlocal bond between systems could be part of Reality -as we do know now- much less sterile argumentation with much more mutual understanding of their respective philosophical stances would have ensued. It takes two to tango: they were very engaged (entangled) but never communicated (connected) one to another. Of course, those titans of Science did not have the benefit of hindsight we do almost a century later [3].

2.4 Categories of Physical Interactions

In Part I we anthropically defined a ‘Gauge Interaction’ (GI) and a ‘True Measurement’ (TM), but we emphasized that they occur all the time in Nature [4]. The *reality* of *probable* states and properties has been elusive for so long because it cannot be grasped directly from a GI (which only can produce *actual* state/properties). The *ontic* character of probability can solely be recognized via the consistency and predictive/explanatory power of its postulation. To this purpose, we need to formally propose five fundamental types of PIs that occur with or without our intervention.

2.4.1 Quanton Emission Interaction (QEI)

A QEI produces one or more quantons. It can be natural as sunlight; or as when radioactivity spontaneously produces α , β or γ quantons (Section 5.1); or when, due to Bohr’s spontaneous electron drops to lower-energy orbits, an atom emits a photon; or via the spontaneous emission Einstein conceived to derive Planck’s Radiation Law. It can also be anthropic as when we shine a piece of metal with high-energy photons to emit electrons via the photoelectric effect; or when we provoke the stimulated emission Einstein also used to derive Planck’s Law and predict laser technology; or with the electron gun of the old TV set [18] [19] [3] [14].

2.4.2 Pure-Detection Interaction (PDI)

A PDI is a sine qua non for what the QT literature calls a ‘measurement’. A PDI is nonlinear and irreversible; ergo, Schrödinger’s Equation cannot govern such a PI: detectors are purposely designed to behave nonlinearly so unitarity, superposition, entanglement, etc. are not realistic concepts [13] [14] [44]. When a quanton undergoes a PDI, its only next state is always *actual* irrespective of its *current* state being *actual* or *probable*. It is thus a transition from a single probable or *actual* state to a single actual state, **not** from many actual states to one actual state (as the ‘measurement problem’ is typically articulated). The *actual* quanton’s state-transition in a PDI may be accompanied by a macroscopic record in RT-spacetime or not. If such an evincing record occurs, it is the result of a physical detection and amplification process (e.g. Geiger counter, photomultiplier, plant leaf, animal’s eye). Being the quanton state/properties after a PDI actual, we show in Part IV that an **R-Time** can always be assigned to its event – with or without a record in RT-spacetime [1].

GIs (and hence TMs) must include at least one PDI to either register a spontaneous transition or to force a transition. This is simply because, if anthropic, the GI’s purpose is to empirically

corroborate the **PD** predicted by **QT** – which we accomplish through the statistical *data* analysis of numerous presumed-equal experimental setups. PDIs occur all the time without our intervention and are the triggers of *actuality* in Nature. A PDI may be destructive or not [43] [34] [45]: the former absorbs the quanton with no further interactions possible; the latter leaves the quanton in an *actual* state and capable of further interactions. For instance, in a bubble chamber, upon a sequence of interactions with the quanton, the superheated liquid locally and irreversibly transitions to a stable gaseous phase, detecting, amplifying, and registering the quanton’s path. Epistemically, the lack of an explicit PDI as the last **PI** for a quanton amounts to a destructive PDI, so an *actual* state/**R-Time** can be assigned after the last **PI** despite the absence of a PDI. This *implicit* assignment is routinely applied by quantum engineers [46] [47] [3].

As explained, different *probable* states of a single quanton may be correlated to spacelike-separated **PIs**; ergo, if one of these **PIs** is a PDI, and the corresponding *probable* state becomes *actual*, all other *probable* states for the quanton are rendered neither *probable* nor *actual* (only one in the **MB** may be *actual*). This is explained by realizing that a) the *quanton* is the real object; and b) its *states* and *properties* are also real, but they evolve as the quanton interacts with its milieu. Subconsciously thinking of the photon as a localized object with only *actual* states/properties, which finally shows up in only one of those spacelike-separated **PIs**, led Einstein to demand a “spooky action at a distance” even for a single quanton [18] [19] [3] [1].

2.4.3 Pure-Transformation Interaction (PTI)

A PTI is purely transformational and lacks a **PDI**. When a quanton undergoes a PTI, if its *current* state is probable, its *next* states are all probable; if its *current* state is actual and belongs to the **MB**, its only *next* state is actual; otherwise its *next* states are all probable. Unless the *current* state is already actual and a member of the current **MB**, the state is *not actualized* because there is *no* physical detection (**PDI**). In general, the *next* states are all real probable states with different probabilities. Note that in the Many Worlds Interpretation (MWI), the *current* state (in the *previous* **MB**) and *next* states (in the *current* **MB**) are purportedly all actual (though in different ‘worlds’).

Whether the *current* state is mixed, convex, pure, or a co-state, its expression as a superposition of states in the *current* **MB** can be seen as transforming the *current* state (actual or probable) into several probable next states – from one next state if the *current* state is in the *current* **MB**, up to as many next states as the **MB**’s cardinality. All transitions between *current* and *next* states in a PTI are probable; *no* actual transitions occur, so they are not dynamic processes. Per **TOPI**, these probable states are (paraphrasing Schrödinger) “determining parts” of the ontic *current* state which are elicited by the *current* milieu. Obviously, as described, this transformation is not one-to-one but one-to-many; otherwise **QT** would be *deterministic*. However, if the *current* state (a member of the *previous* **MB**) is probable, all other states in the *previous* **MB** are also probable and ‘determining parts’ of the *previous* state. Understanding this is paramount.

Combining all the one-to-many transformations (one for each probable state in the *previous* **MB**), we obtain a *unitary* transformation between *previous* and *current* **MBs**, i.e. a basis transformation \mathcal{U} which is linear, deterministic, and reversible with $\mathcal{U}^{-1} = \mathcal{U}^\dagger$. That is true e.g. for the **BS** and **PBS** equations when both input states $|i_1\rangle$ and $|i_2\rangle$ belong to a single quanton’s *previous* **MB**. But any transformation \mathcal{U} between two bases used to represent a single state can be viewed as a transformation between two states under a single basis. Furthermore, the components of those two states in the single basis transform as the bases do, i.e. under \mathcal{U} . Ergo, \mathcal{U} can also be

interpreted as transforming the *previous* state into the *current* state or, equivalently, as transforming (as a whole) the components of the *previous* state into the components of the *current* state – and mutatis mutandis between *current* and *next* states. Hence, despite the stochasticity of **QT**, **U** is interpretable as a linear, reversible, deterministic evolution of probable states.

Stunningly, despite all states in a PTI being (in general) probable, the last interpretation allows for a deterministic reversible relation between *previous*, *current*, and *next* states, implying that a quanton under a given milieu may evolve without revealing itself in our **RT**-spacetime (no **PDI**). We referred to this in our Part I as ‘quantic determinism’ [4]. That is precisely what **Schrödinger’s Equation** does when the single **MB** is the Hamiltonian Basis and *previous*, *current*, and *next* states are infinitesimally close: it describes one type of deterministic evolution for the quanton’s energy probability distribution. Clearly thus, such ‘evolution’ cannot be in **R-Time** but in **QR-Time**. The relationship between the two (the latter including the former) will be elucidated in Part IV [1].

In brief, a PTI deals in general with probable states, so it cannot be of the *dynamic* type in **RT**’s spacetime: without a **PDI**, **R-Time** (actual by Einstein’s conception) is inapplicable, explaining why a PTI is considered the quintessence of quantum oddities. The shocking *reality* of PTIs has been proven beyond doubt by modern quantum cryptography and quantum computer⁵ technologies [3] [47] [46]. We will use it to probe and prove the *reality* of probable states.

2.4.4 Intrinsic Tele-Interaction (ITI)

This is an immanent (constitutional) **PI** between probable states of a single quanton or between sub-quantons of a composite quanton in an *entangler* state. Every **PTI** has an ITI and every ITI corresponds to a **PTI**. In the single-quanton case, the intrinsic interaction resides in the conditional probability relations between all probable states in the **MB** throughout the quanton’s evolution: any conditional probability for a probable state which is *not* the condition itself is nil; otherwise, it is less or equal to unity. Thus, when the quanton undergoes a full **PDI**, only one of the probable states becomes actual and susceptible of manifesting in our **RT**-spacetime. In the case of a network of **PTIs** (**Section 3**), the above is true for the probable states in each of the local **MBs**; globally, as it will be proved, the ITI among probable states across different **MBs** takes place not via their probabilities but through their components (probability *amplitudes*). Einstein denounced this ‘abhorrent one-particle nonlocality’ at the Solvay 1927 meeting – to be fully studied in Part IV [1].

As for the multiple-quanton case in an entangler state, because the sub-quantons could be spacelike separated, ITIs achieve Einstein’s and Schrödinger’s ultimate anathema: “spooky action at a distance” between quantons. Ergo, like **PTIs**, their ITIs are not of the *dynamic* type in **RT**-spacetime: sub-quantons’ eigenstates and their reciprocal conditional probabilities are all *real* and probable, becoming actual only if and when any one of the sub-quantons undergoes a **GI** with its local milieu. For instance, in **EPRB** (**Figure 3**), when Qubit-A undergoes a **GI**, the opposite of its post-**GI** (now *pure*) state is *teleported* to Qubit-B, so the latter’s state is (whether it may eventually undergo a **GI** or not) as actual as Qubit-A state is after its **GI**. The tele-interaction existed all along while (in **R-time**) the composite quanton remained isolated: it consisted of the reciprocal probability interrelationship between the eigenstates in the sub-quantons’ local **MBs** (**Equations**

⁵ On 12/04/2023, IBM unveiled the [first quantum computer with 1,121 superconducting qubits](#).

12) – irrespective of any of them ever undergoing a **GI**. When a **GI** does happen, the actual teleportation does happen. Part IV thoroughly examines it vis à vis Special Relativity [1].

Notice that we cannot control which actual state is teleported, so **no** information can be spookily transmitted by us. What is called ‘teleportation’ in the literature is ‘teleportation at will’ so, because quantons cannot be cloned at will, it also requires a modicum of human communication (i.e. limited by the speed of light) between the distant sites (Part IV [1]). Notice as well that **TOPI**’s teleportation occurs even when the two sub-quantons would manifest in our **RT**-spacetime as **uncorrelated**. As explained, in such a case, the sub-quantons’ behaviors are **uncorrelated** not because they are isolated but because they are entangled while interacting with a unique global milieu ($\theta = \pi/2$ or $3\pi/2$ in **EPRB**).

2.4.5 Pure Entanglement Interaction (PEI)

This is a **GI** jointly experienced by two or more independent quantons after which they come out *entangled*. The states in the **MB** for a PEI are **composite** states. Before the PEI, each quanton has its own *pure* state; after the PEI, the composite quanton is in a *pure* state with each of the sub-quantons in a *co-state*. A PEI converts the *pure product* state of the input composite quanton into a *pure entangler* state; as for the sub-quantons, a PEI transforms their *pure* states into *co-states*. *No unitary* transformation could produce *co-states* from *pure* states (or vice versa). The phase *coherence* characteristic of a *pure* state in which the quantons were before a PEI is totally lost after they entangle – with the created composite state being the one that is *pure* and coherent. *Interference* for the sub-quantons as individuals is impossible: their *incoherence* is the byproduct of their entanglement.

For two qubits with individual state-spaces A and B , there is a PEI called the ‘Bell Interaction’ whose Milieu Basis is $\text{MB} = \{|B1\rangle, |B2\rangle, |B3\rangle, |B4\rangle\}$ (the ‘Bell Basis’). These eigenstates are:

$$\begin{aligned} |B1\rangle &= \sqrt{2}/2 \{ |s_{A1}\rangle |s_{B2}\rangle - |s_{A2}\rangle |s_{B1}\rangle \} \quad ; \quad |B2\rangle = \sqrt{2}/2 \{ |s_{A1}\rangle |s_{B2}\rangle + |s_{A2}\rangle |s_{B1}\rangle \} \\ |B3\rangle &= \sqrt{2}/2 \{ |s_{A1}\rangle |s_{B1}\rangle - |s_{A2}\rangle |s_{B2}\rangle \} \quad ; \quad |B4\rangle = \sqrt{2}/2 \{ |s_{A1}\rangle |s_{B1}\rangle + |s_{A2}\rangle |s_{B2}\rangle \} \quad (13) \\ &\quad \downarrow \\ \langle B1|B2\rangle &= \langle B1|B3\rangle = \langle B1|B4\rangle = \langle B2|B3\rangle = \langle B2|B4\rangle = \langle B3|B4\rangle = 0 \end{aligned}$$

The eigenstates $|B1\rangle$ and $|B3\rangle$ are the maximally entangled spin states ($\theta = 0$ and $\theta = \pi$) in **Equations 11** (top line). In the literature, $|B1\rangle$ is called the ‘singlet’ and the other three are called the ‘triplet’ states. The orthogonality relations at the bottom confirm that the four Bell States constitute a basis for $S_A \otimes S_B$. Thus, any **GI** with the Bell Basis as its **MB** is a PEI that will haphazardly leave the composite quanton in an actual state (one of those four Bell states). Any **PTI** (no **PDI**) with such **MB** will set all those eigenstates as probable composite states.

A PEI can be natural, e.g. when the product of radioactivity is a pair of *entangled* photons. It can be anthropic, e.g. when we shine laser light onto an atom, or when we design a **Spontaneous Parametric Down-Converter** (photons entangled in polarization), or when we direct two optical fiber cables into an optical coupler (photons entangled in location). Two quantons can also become entangled without having a common past (common source) or interacting directly, e.g. when each one is entangled with one of two quantons submitted to a ‘Bell Interaction’ [37] [1].

2.4.6 Generic Physical Interactions

Most **PIs** are combinations of the prior five **PIs**, so we can now further elaborate on the **EPRB** experiment. Were the first local **GI** non-destructive⁶, subsequent **TMs** on the now-independent quantons would simply detect their antipodal actual states; any other **GI** would produce a random actual state with a **PD** determined by the quanton's actual pre-**GI** state and the **GI**'s **MB**. A **PTI** whose **MB** did not contain the quanton's actual state would transform it into as many probable states as the **MB** cardinality; a **PTI** whose **MB** contained the quanton's actual state would leave the quanton in the same actual state. But, had the very original **GI** underwent by Qubit-*A* been a **PTI** (no **PDI**), all its next states would have been probable and its entanglement with Qubit-*B* would have not ceased. Qubit-*A* and Qubit-*B* would have continued being in *co-states* (with a different **ITI**). Both spacelike sub-quantons stay entangled until one of them experiences a **PDI** (explicit or **implicit**), which transforms its *co-state* and the *co-state* of the other into actual pure isolated (albeit related) states.

The so-called state-preparation process, obviously anthropic by name, is conceived to deliver the quanton in an *actual* or *probable* state; the reason is that *we* do know what that state is before it undergoes further interactions. But state-preparation can also be natural, like when radioactive elements are created during supernovae explosions or when stable isotopes interact with high-energy quantons. Anthropic or natural, state preparation can be the result of a **QEI**, a non-destructive **PDI**, a **PTI**, a **PEI**, an **ITI**, or their combinations. Note that, even when a state is *probable*, it can be known by us. For instance, in a Stern-Gerlach setup (**Figure 2** bottom-right), we say an atom, if detected in the upper beam, was 'prepared' in the 'up' spin state and, if detected in the lower beam, was 'prepared' in the 'down' spin state. But, until detection occurs, both states are *probable* and, being correlated to different paths, we know what those *probable* states are. The same can be said when a photon enters a **PF**: the *probable* state in the output channel corresponds to a polarization along the optic axis of the **PF**.

2.5 Photonic Instantiation of **QEIs**, **PDI**s, **PTI**s, **PEI**s, and **ITI**s

The magnetic-spin instantiation of **QEIs**, **PDI**s, **PTI**s, **PEI**s, and **ITI**s was tacitly done while discussing mixed, convex, pure, and *co-states*. Let us now do the same with light quanta.

Figure 4 outlines four possible cases for an open network of **PIs**: (a) a laser embodying a **QEI**; (b) a Spontaneous Parametric Down-Converter (SPDC) embodying a **PEI** that creates a pair of entangled photons; (c) a **BS** instantiating a **PTI** and the internal **ITI** between the photon's probable states; and (d) three photo-detectors D_R , D_1 , and D_2 embodying three **PDI**s. The SPDC is a nonlinear birefringent crystal that, upon receiving an ultraviolet photon, emits two lower-energy photons. The laser feeds the SPDC with trillions of photons per second, producing about 4 entangled pairs per million laser's photons. The two photons are correlated in time, momentum, and energy. Also, due to the crystal's refractive index varying with the photons' polarizations, the latter property can also be correlated.

The firing of D_R attests for the creation of a photon pair and the entrance of a photon to the **BS**; D_1 detects photons transmitted through and D_2 reports photons deflected from the **BS**. Detectors that fired are displayed in solid green. After statistically analyzing firing coincidences,

⁶ Delaney, R.D., Urmeý, M.D., Mittal, S. *et al.* Superconducting-qubit readout via low-backaction electro-optic transduction. *Nature* **606**, 489–493 (2022). <https://doi.org/10.1038/s41586-022-04720-2>.

it is concluded that only the top two and not the other two cases in Figure 4 occur, viz: once a photon has entered the beam splitter, either D_1 or D_2 fires but *not* both. In fact, the authors in [48] found that “whether the separation between detectors is timelike or spacelike, the number of coincidences is three orders of magnitude smaller than what would be expected had the events been uncorrelated”. In sum, for this GI (one PTI plus two PDIs), based on actual data, the two paths seem to be mutually exclusive as for the quincunx’s ball after hitting a pin.

The absence of D_1 and D_2 coincidences is interpreted as proof of the existence and *discrete* character of the photon. Were the latter an actual wave, say its de Broglie wave [19] [3], either both detectors would fire at once or a ‘spooky action at a distance’ would occur so that when one detector fires, the wave would *instantly* disappear from everywhere. Likewise, were the photon an actual Schrödinger’s wave-packet, the BS would split it into two actual wave-packets concurrently traveling towards D_1 and D_2 and, because only one detector fires, again a sort of *nonlocal* effect would be in place. With only 20 meters between detectors, had the disappearance of the wave-packet traveling towards D_1 been *caused* in RT-spacetime by the firing of D_2 (or vice versa), such a cause-effect ‘signal’ would have had to travel about 20 times faster than light – against RT [49].

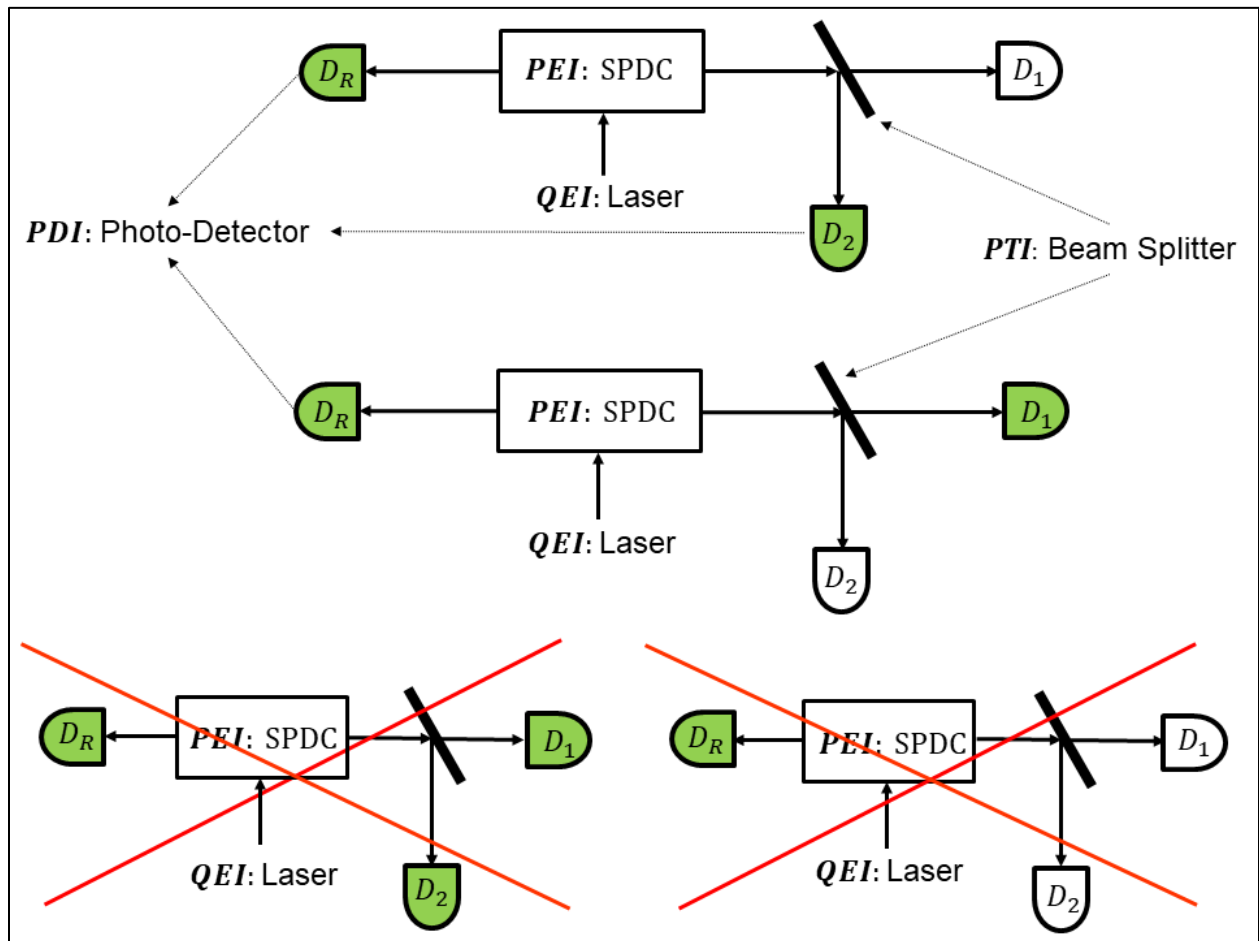

Figure 4: Photonic Instantiation of QEI, PEI, PTI, ITI, and PDIs

Per TOPI, instead, an ITI between probable states of a single quanton exists all along the photon’s evolution, which results in only one of them being actual when undergoing a PDI.

Of course, being ‘discrete’ does not mean the photon is a classical particle with only actual states. By recombining the transmitted and deflected paths (e.g. with two perfect mirrors) into a second **BS**, the combined PTI the photon undergoes before detection is radically changed. Such a composite milieu for a photon is known as the Mach-Zehnder Interferometer (MZI). We will soon see that the second **BS** is exposed to *two probable* states of a *single* photon and, being probable states as *ontic* as actual states, a dumbfounding nonlocal/interference phenomenon may take place, forcefully preventing any naïve interpretation of the photon as the traditional actual particle or actual wave we are accustomed to in our macroworld.

3. TOPI: Probing and Proving the Reality of Probable States/Properties

As we saw in **Figure 4**, different milieus imposing different **PIs** for a quanton can be *spatially* networked establishing a composite milieu, which defines a global **PI** whose state-transition **PD** for the quanton varies with the network topology. Individual **PIs** (nodes of the network) may involve several *probable* states of a single quanton. The network with its nodes and connections may be physical as such (**Figure 4**) or representational, e.g. when we analyze how light reflects from the two outer surfaces of a piece of glass, in which case the surfaces would be represented by the nodes in the network [34].

If all **PIs** in a network are **PTIs** and the input state(s) is(are) *probable*, *no actual* states exist throughout the network irrespective of its spatial extension and, ergo, *no R-Time* can be assigned to any intermediate **PTI**. An *R-Time* can be assigned to the first **PTI** only when the input state (or one of them) is *actual*. As for the last **PTI**, as we said, the lack of a **PDI** amounts to a destructive **PDI**, so an *actual* output state/*R-Time* can be assigned after the last **PTI** despite the absence of a physical last **PDI**. Once again: when all **PIs** between two *R-Times* involve only *probable* states, no narrative of the ‘wheels and gears’ type can be verisimilar because a part of Reality is ignored.

If a quanton undergoes several serial/parallel **PTIs**, the state-transition **PD** from the *input* state (before the first **PTI**) to the *output* states (after the last **PTI**) is *not* determined by the interaction of intermediate actual states (there are none) but by the interplay among the multiple intermediate probable states the quanton *has*. This interplay between probable states involves **ITIs** and, *not* taking place in *RT*-spacetime, it is empirically *inaccessible* as such. The only way to empirically verify/infer such interactions is by adding a **PDI** *after* the last **PTI** (i.e. by making the last **PI** a **GI**) so we acquire actual data. Attempting otherwise by inserting an *intermediate non-destructive PDI*, we would modify the quanton’s global milieu, actualizing some otherwise intermediate probable state and influencing all other **PIs** in the network. By its very nature, the reality of a probable state must be *inferred* via experiments that do not convert it into an actual state.

As we learned, these **PTIs** involving only probable states are dictated by the network’s topology but *not* in *R-Time*. From the individual state-transition **PDs** for the **PTIs** (nodes) and the topology of their milieus, **QT/TOPI** predicts the overall state-transition **PD**: there is no storyline of intermediate actual events in *R-Time*. This is only true if *no PDIs* occur between the network’s *input* and *output* states, namely if the quanton never adopts an *intermediate actual* state. The insertion of an *intermediate PDI* would effectively create another *R-Time* between *input* and *output R-Times*. This is the essence of the clash between **QT** and **RT**. Let me emphasize again that when I say that the ‘evolution’ of probable states occurs in *QR-Time* (*not* in *R-Time*), I am not endorsing the existence of two types of *time*; I am instead saying that Einstein’s operational definition of *time* in **RT** is insufficient to fully represent Reality – the subject of our Part IV [1].

3.1 Probing the Reality of the Photon's Probable States/Properties

In **Figure 5**, besides the arrows indicating the polarization state, we use ‘p’ and ‘a’ to indicate *probable* and *actual* states. When two or more *actual* states correspond to the same quanton with the same **MB** they are dot-encircled to indicate that only *one* of them exists. **Figure 5** (top-left) displays a **PBS** with the polarization for input $|i_1\rangle$ in solid black and for input $|i_2\rangle$ in dotted-red. We also assumed that, if their corresponding states are both *actual*, they do correspond to the same quanton with the same previous milieu (both ‘a’ are dot-encircled). As for the **PBS** output channels $|o_1\rangle$ and $|o_2\rangle$, they are both *probable* states for the same quanton. By their very nature, *probable* states of the same quanton/milieu do coexist; *actual* states of the same quanton/milieu do not. Note that the same output contains (\uparrow) and (\rightarrow) *probable* states (one for each input) because a deflected state for one input is a transmitted state for the other. But after the quanton undergoes a **PDI**, i.e. a photodetector in one channel does (does not) fire, the quanton's *probable* state on that (the other) channel becomes *actual* and, ergo, the state on the other (that) channel is meaningless.

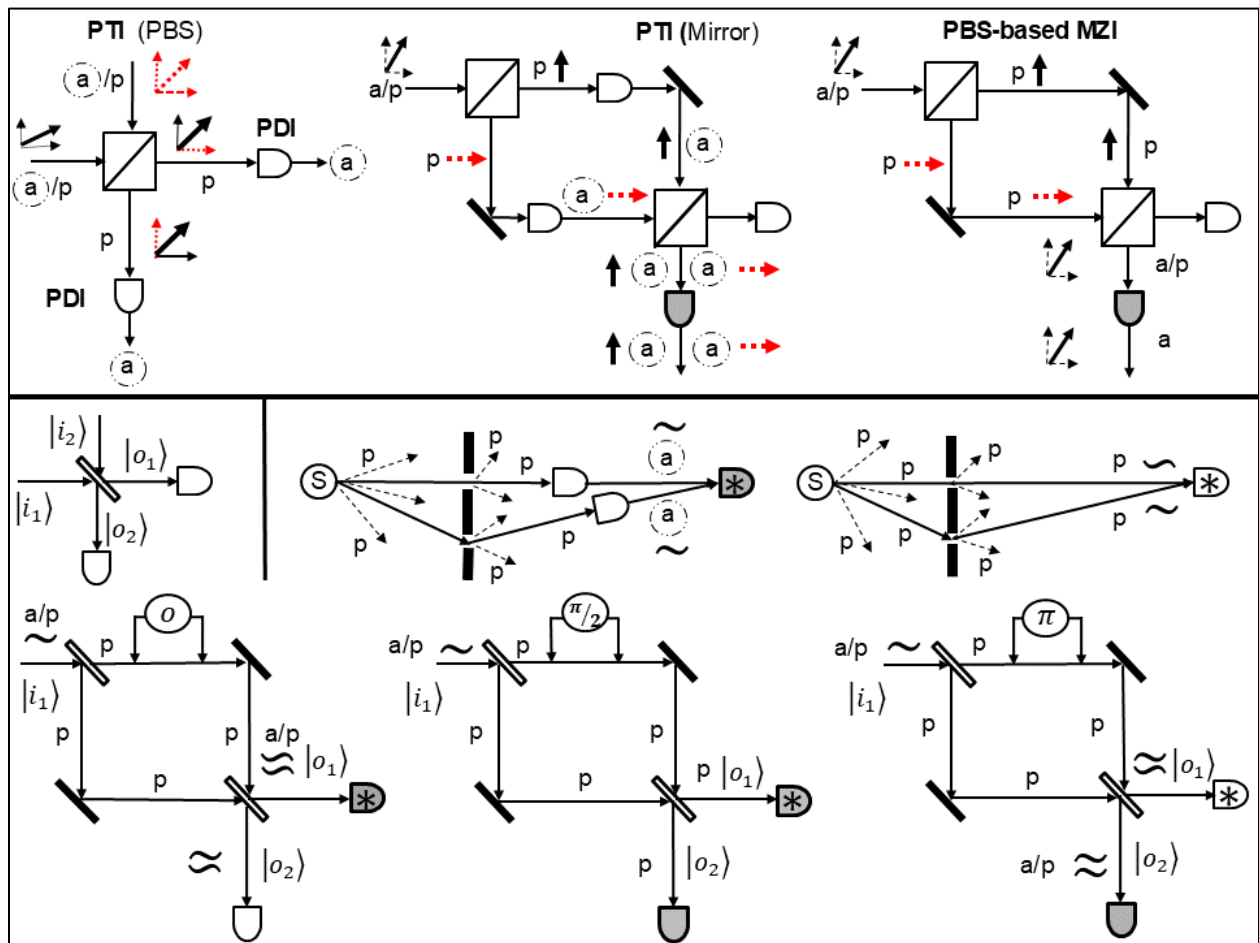

Figure 5: Probable (p) vs. Actual (a). Top: MZI with PBS; Bottom: Double-Slit as an MZI

In **Figure 5** (top-middle), we assume the two **PDI**s after the **PBS** are non-destructive and we close the topology by getting both output channels of the **PBS** to (via perfect mirrors) enter a second **PBS** with the same spatial orientation as the first one (their T-axes are collinear). The states out of the first **PBS** are both *probable* but, because of the **PBS** operation, the state in the upper path has (\uparrow) polarization (solid-black arrow) and the one in the lower path has (\rightarrow) polarization

(dotted-red arrow). Polarization and path are correlated. And, due to the **PDI**s in the loop, *only* one of the states enters the second **PBS** as *actual*, i.e. the second **PBS** interacts *either* with the quanton in a (\uparrow) state (upper path) *or* with the quanton in a (\rightarrow) state (lower path). In the first case, the photon is transmitted and the lower photodetector fires; in the second case, the photon is deflected firing the same lower **PDI**. The upper-right detector never fires. In rigor, only one **PDI** is strictly necessary in the loop because, upon the only (ideal) **PDI** interacting with the *probable* state in that physical channel, if the detector fires, the latter becomes *actual*; if it does not, the *probable* state in the other channel is the one that becomes *actual*. After a multitude of single-photon runs, each one with an initial polarization forming an angle of, say 30° with the **PBS** T-axes, about 75% ($\cos^2 30^\circ$) of the photons will come out with (\uparrow) polarization (solid-black arrows) and about 25% with (\rightarrow) polarization (dotted-red arrows). The second **PBS** makes no difference, except for allowing the photon in each run (either by being transmitted or deflected) to hit the lower detector.

As an experimental proof of the last assertion, replacing the detector in the firing channel with a third **PBS** (with the same spatial orientation), it would transmit all 75% of the photons with (\uparrow) polarization and deflect all 25% of the photons with (\rightarrow) polarization. But if we rotated this third **PBS** 30° to align its T-axis with the polarization of the photon when entered the first **PBS**, the 75% of photons with (\uparrow) polarization will now split 56.25% (75% of 75%) as transmitted and 18.75% (25% of 75%) as deflected. The remaining 25% of photons with (\rightarrow) polarization will split 6.25% (25% of 25%) as transmitted and 18.75% (75% of 25%) as deflected. Adding the photons in each output, we would obtain 62.5% of the photons polarized at 30° and 37.5% polarized at 120° (relative to the orientation of the two **PBS**s inside the loop). Being all states *actual*, we simply multiplied all probabilities for conjunctive states in each of the disjunctive states and added them all – as we did with the **quincunx**. As with *epistemic* probabilities, the probabilities are the ones that intermingle, not the probability-amplitudes; however, *probability* is still ontic: it is the presence of a **PDI** acting on one of the two *probable* states that effectively converts them into a single *actual* state, obliterating any direct evidence for their *reality*, and allowing us to think of probability as simply ‘lack of knowledge’.

3.2 Proving the Reality of the Photon’s Probable States/Properties

Here is how we prove the *reality* of the *probable* states: we now remove both **PDI**s in the loop so all states in it remain *probable* throughout the network (**Figure 5/top-right**). This is a **PBS** version of the well-known Mach-Zehnder Interferometer (MZI). If *probable* states are a merely helpful figment of our intellect (epistemic) and only *actual* states/properties are *real*, since *actual* states are mutually exclusive, the second **PBS** would *only* interact with one state via one input, and we would be in the same situation as described in the previous section. If, instead, *probable* states are *real* and ontically more fundamental than *actual* states, there must be an experimental difference when those *probable* states are converted into *actual* upon a **PDI** *outside* the loop. Let us first see if **QT** predicts something different to when there was a **PDI** inside the loop.

Using **PBS Equations**, we first express the only input state $|s\rangle = |\nearrow, i_1\rangle$ to the MZI in the **MB** of the first **PBS** ($MB = \{|t\rangle, |d\rangle\}$) to get $|s\rangle = \cos\theta|\uparrow, t\rangle + \sin\theta|\rightarrow, d\rangle$. The states $|\uparrow, t\rangle$ and $|\rightarrow, d\rangle$ are respectively those of the photon in the upper (transmitted) and lower (deflected) channels. But $|\uparrow, t\rangle$ becomes $|\uparrow, i_2\rangle$ of the **second PBS** while $|\rightarrow, d\rangle$ becomes its $|\rightarrow, i_1\rangle$, so we can express both intermediate probable states in the **MB** for the second **PBS**, i.e. $\{|\rightarrow, o_1\rangle, |\uparrow, o_1\rangle, |\rightarrow, o_2\rangle, |\uparrow, o_2\rangle\}$. And using again **PBS Equations** we obtain:

$$\begin{aligned}
|\nearrow, s\rangle &= \cos\theta|\uparrow, t\rangle + \sin\theta|\rightarrow, d\rangle \\
&\Downarrow \\
|\nearrow, s\rangle &= \cos\theta\{-\sin(0)|\rightarrow, o_1\rangle + \cos(0)|\uparrow, o_2\rangle\} + \sin\theta\left\{\cos\left(\frac{\pi}{2}\right)|\uparrow, o_1\rangle + \sin\left(\frac{\pi}{2}\right)|\rightarrow, o_2\rangle\right\} \\
&\Downarrow \\
|\nearrow, s\rangle &= -\cos\theta\sin(0)|\rightarrow, o_1\rangle + \cos\theta\cos(0)|\uparrow, o_2\rangle + \sin\theta\cos\left(\frac{\pi}{2}\right)|\uparrow, o_1\rangle + \sin\theta\sin\left(\frac{\pi}{2}\right)|\rightarrow, o_2\rangle \\
&\Downarrow \\
|\nearrow, s\rangle &= \cos\theta|\uparrow, o_2\rangle + \sin\theta|\rightarrow, o_2\rangle = 0|o_1\rangle + 1|\nearrow, o_2\rangle \tag{14}
\end{aligned}$$

Given the **MBs** for each of the nodes (**PIs**) in the network and its topology, the photon's input state $|s\rangle$ is finally expressible as a 2-superposition of two polarization states in a single output channel. In such symbolic state manipulation, it is easy to see that now the probability-amplitudes (not the probabilities) are the ones that are multiplied for conjunctive states in each of the disjunctive states and finally added. The final state-transition equation shows that, regardless of the polarization (θ) of the photon entering the MZI, it comes out in the lower stream with the same polarization ($|\nearrow, o_2\rangle = |\nearrow, s\rangle$) and fires the **lower** detector. **QT** thus predicts that, after many one-photon runs, each one with a polarization forming an angle of say 30° with the first **PBS** T-axis, 100% of the photons coming out will have polarizations not (\uparrow), not (\rightarrow), but forming the **same** angle of 30° with the T-axes of both **PBSs**. Remarkably, the first **PBS** decomposed the original *actual* polarization (\nearrow) associated with a single (input) physical channel into two *probable* polarizations: one (\uparrow) and one (\rightarrow), each one correlated to only one of the two physical channels in the loop; and the second **PBS** composed them back to the original single polarization. Note that because the $|o_1\rangle$ component is zero, if the input state was *actual*, the output state is *actual* (even before the detector). Having removed all **PDI**s (no actual states), the global milieu (MZI) to which the photon was exposed constituted a **PTI**, within which (except for the input which could have been *actual*) all *probable* states coexisted. Finally, for a probable input state, the lower **PDI** (the photodetector) converted the *probable* state into *actual*, manifesting itself in our **RT**-spacetime.

To experimentally prove the above prediction, we replace the **PDI** in the firing channel with a third **PBS** spatially rotated 30° with respect to the other two and find that 100% of the photons are transmitted. This result is in stark contrast with the only 62.5% of photons that we saw would have been transmitted had *probable* states had **no** reality. Clearly, interaction between the **two probable** states of a **single** photon (a global **ITI** established by the local **PIs** in the network plus its topology) was present – with undeniable empirical consequences. Instead, for high-intensity light under the wave theory, we would say that the two beams actually going through the second **PBS** have constructively interfered in one of the outputs and destructively interfered in the other.

Some authors interpret the above astounding experimental evidence as proving the **reality** of *superpositions* per se [37] [50] [51] [52]. But we know that, even though only the superposition obtained with the **MB explicitly** reveals the next *probable* states and their probability amplitudes for each **PI** in the network, any other superposition is equally legitimate (though more burdensome) to represent the state. Per **TOPI**, the **states/properties** (actual or probable) are the ones which are **real** – as features of the entities in the theory's *Ontology*, viz the quantons [4]. *Superpositions* are merely clever mathematical representations of the ontic **states**, so conceived to expedite and efficiently handle any topology of **PIs** to which the quanton could be exposed – as we did

intuitively with the high-intensity light/atomic beams, the **quincunx**, and will do as well for Schrödinger's **diabolic machine**.

3.3 Further Proof: The Iconic Young's Double-Slit Experiment

When technology managed to dim light intensity down to a single photon, the 'double-slit experiment' became the epitome of quantum interference [34] [18] [19] [3]. The *polarization* states did not critically depend on the *distance* between nodes of the network, only upon its topology. Instead, for the 'double-slit experiment', *distance* is crucial because the relevant features of a single photon are the *quantic* versions of *phase* and *coherence* for a macro-object: the **electric field**.

From **Figure 5** (bottom half/top middle and right plots), the state of a single-frequency photon at the source 'S' can be decomposed into a disjunctive continuum of conjunctive continuous state-transitions (probable paths to the detector), two disjoint subsets of which include the passage through the slits. Each slit constitutes a local **PTI**. The size of and distance between slits is small enough that the *probabilities* for the photon to reach the detector via the lower slit (upper slit closed) and via the upper slit (lower slit closed) are about the same. This is because in both cases -were the photon a classical particle with only actual states- the transit **R-Times** to the detector would differ little and both would be local extrema, so both *probabilities* are mostly determined by those paths [34] [19]. Pithily: those two subsets of possible paths constitute the relevant milieu for the photon. This 'ability' to spread (lower slit open), known as *diffraction* for high-intensity light, is implied by the misnamed 'Principle of Uncertainty' [4] [3]. Epistemically, for many single-photon experiments, the ratio between the number of clicks by the detector and the number of photons from the source is roughly the same when any but only one slit is open.

But both slits are supposed to be open and, were those state-transitions (paths) **actual**, they would be mutually exclusive (**Figure 4**) and the two-slit probability to reach the detector would be the sum of the one-slit probabilities. Equivalently, the number of clicks for the same large number of single-photon runs would roughly duplicate. That is experimentally confirmed when inserting non-destructive ideal (100% reliable) detectors after the slits (**Figure 5**, 1st setup) because the two *probable* paths of the photon are converted into a single **actual** path (only one inner detector fires). Small changes of the distance between slits would be irrelevant. As with the **PBS-based MZI**, only one (ideal) **PDI** is needed because its non-firing implies that the state in the other path is **actual**.

But, removing those **PDIs** (**Figure 5**, 2nd setup), both paths are optically *probable*. The probability for the final detector to fire varies with the position of, say, the lower slit (i.e. the source/detector *distance* for the lower path): tiny changes in the slits' spacing alter the probability periodically from *zero*, through the *sum* of the one-slit probabilities, to about *double* that sum. In the first case, **no** clicks ever occur, i.e. the photon does not show up; this is full *destructive* interference between its **two probable** states at the detector (the case depicted). In the second case, the photon behaves like a macro-object, i.e. as if it only had *actual* states (like the ball in the **bean machine**); **no** interference exists. In the third case, the number of clicks is double the clicks in the second case. This is fully *constructive* interference between the **two probable** states of a **single** quanton right before interacting with the detector. Initial state and milieu (distance between slits and from them to the detector) jointly determine the behavior.

Because it is **not** the probabilities (nonnegative real numbers) but the probability-*amplitudes* (complex numbers with phases) the ones that intermingle (as electric fields do for **high-intensity light**), the final *probability* of a single photon (*number* fraction of photons per unit area for **high-**

intensity light) -determined via the squared modulus of the net amplitude- can be weakened or amplified. The actualization of an elaborate **ITI** among the photon's probable states takes place at the detector. And, for a fixed distance between the slits, interference phenomena manifest differently for different positions of the final detector (different spots on a photo-sensitive screen), building up the well-known interference pattern [3].

3.3.1 The Double-Slit Experiment as a Mach-Zehnder Interferometer

Per the above analysis, the gist of **Young's iconic experiment** can be reduced to a double-path MZI setup in which the basic module is a **BS** with two inputs and two outputs (lower half of **Figure 5/top-left**). We set the homology as follows: a) because the MZI has two outputs, we focus on one of them (asterisked in homologous setups); b) the effect of adjusting the gap between slits is attained by tweaking the length of the upper arm in the MZI.

Per **Equations 6**, to complete the homology between double-slit and MZI setups, we choose both splitters (\underline{BS}_1 and \underline{BS}_2) to be 50/50 ($T = R = \sqrt{2}/2$) as well as, for simplicity, to be both symmetric ($\delta_1 = \delta_2$). Hence, **Equations 6** specialize to **Equations 15**, with the phase shift between transmitted and reflected states for both inputs equal to $\pi/2$:

$$\underline{BS}_1 = \underline{BS}_2 = \underline{BS} = \frac{\sqrt{2}}{2} \begin{bmatrix} 1 & i \\ i & 1 \end{bmatrix} \Leftrightarrow \underline{BS}_1^\dagger = \underline{BS}_2^\dagger = \underline{BS}^\dagger = \frac{\sqrt{2}}{2} \begin{bmatrix} 1 & -i \\ -i & 1 \end{bmatrix} \quad (15)$$

Such a symmetric **BS** shows that, for both inputs states, transmitted and input states are in phase, while reflected and input states are in quadrature. These phase relations for the first **BS** intermingle with those of the second **BS** because the former's outputs become the latter's inputs. The perfect identical mirrors (**PTIs**) in both arms of the MZI impose the same phase shifts upon reflection so that their effects cancel out and can be ignored. But, besides the phase gained upon *reflection* from the **BSs** and perfect mirrors, there are other contributions to the final phase of each probable state coming out of the MZI, which are: a) the small phase gained inside the two **BSs** upon *transmission*; and b) the phase gained along the arms themselves. Both types are equal to 2π times the respective pathlength divided by the wavelength.

Notice that the concept of wavelength involves the notion in our macroworld of 'traveling' speed, which allows us to predict the phase of a probable state at the entrance of the second **BS** – given the phase of a probable state right after the photon 'leaving' the first **BS**. Hence, adjusting the length of say the upper arm, we can introduce a phase shift at will between the two MZI probable output states $|o_1\rangle$ and $|o_2\rangle$ before reaching the detectors. However, we *cannot* think of the probable states in each arm as 'objects' traveling in our RT-spacetime that meet at the second **BS** to interfere: such 'object' in the longer arm would take longer to 'arrive' – reinforcing our stance that 'evolutions' in **PTIs** and their associated **ITIs** do not occur in **R-Time**. The relative phase between the two probable states corresponds to the relative phase between the two actual high-intensity beams in steady-state (which is independent of **R-Time**) [1].

Let us call θ the phase shift imparted to the photon in the upper arm plus the net effect of all above-mentioned minor phase shifts. Three cases are displayed in **Figure 5/Bottom**: 0° , 90° , and 180° . Before analyzing them in depth, we imagine inserting ideal non-destructive detectors (**PDI**s) in the arms (the homologous double-slit setup is shown in the top-middle plot). Because a single photon enters the MZI at a time, either the two inputs for both splitters are probable or only one is

actual, the latter being the case for the second BS when a PDI is inserted in at least one of the arms. Analyzing many single-photon experiments, the 50% in each arm after the first BS splits 25/25 on the second BS so, focusing on the detector for $|o_1\rangle$ (asterisked), the number of clicks (50% of total inputs photons) is double the number of clicks when one of the arms is blocked (25% of total input photons). In probability terms, probabilities for mutually exclusive actual states do add, as they did for the double-slit setup when comparing the only-one-slit-open case with the two-slit-open setup and a PDI in at least one of the slits. Let us now find the MZI global state-transition in terms of its local state-transitions when *no* internal PDIs exist.

As with the PBS-MZI, we first express the only input state $|s\rangle$ in the MB of the first BS (MB = $\{|t\rangle, |r\rangle\}$) to get $|s\rangle = \frac{\sqrt{2}}{2}(|t\rangle + i|r\rangle)$. The probable states $|t\rangle$ and $|r\rangle$ are respectively those of the photon in the upper (transmitted) and lower (reflected) channels. Because of the phase shift θ included in the upper arm, $|t\rangle$ is transformed into $e^{i\theta}|t\rangle$, which becomes $|i_2\rangle$ of the second BS, while $|r\rangle$ becomes its $|i_1\rangle$, so we can express both states in its basis MB = $\{|o_1\rangle, |o_2\rangle\}$:

$$|s\rangle = \frac{\sqrt{2}}{2}\{e^{i\theta}|t\rangle + i|r\rangle\} = \frac{\sqrt{2}}{2}\left\{e^{i\theta}\left[i\frac{\sqrt{2}}{2}|o_1\rangle + \frac{\sqrt{2}}{2}|o_2\rangle\right] + i\left[\frac{\sqrt{2}}{2}|o_1\rangle + \frac{\sqrt{2}}{2}i|o_2\rangle\right]\right\}$$

$$\Downarrow \quad (16)$$

$$|s\rangle = \left\{\frac{ie^{i\theta}}{2} + \frac{i}{2}\right\}|o_1\rangle + \left\{\frac{e^{i\theta}}{2} - \frac{1}{2}\right\}|o_2\rangle = \frac{i}{2}\{e^{i\theta} + 1\}|o_1\rangle + \frac{1}{2}\{e^{i\theta} - 1\}|o_2\rangle$$

From Equations 16 (bottom) we easily find the input state as a 2-superposition of the output states for $\theta = 0, \pi/2, \pi$. Namely:

$\theta = 0$: Constructive Interference for $|o_1\rangle$ (Destructive for $|o_2\rangle$)

$$|s\rangle = i|o_1\rangle + 0|o_2\rangle \quad (\text{Lower half of Figure 5 Bottom-Left})$$

We see that no photon goes through channel 2 so the detector in channel 1 clicks as many times as the number of single-photon experiments. The phase of $|o_1\rangle$ is the result of a $\pi/2$ shift in the **lower arm** (reflection in the first BS) and a $\pi/2$ shift in the upper arm (reflection in the second BS). Both contributions being in phase, the number of clicks in that detector is double the number when a non-destructive PDI is included (quadruple the number when only one arm exists). Notice the phase of $|o_2\rangle$ is the result of a π shift (two BS reflections) in the lower arm and no phase shift in the upper arm (two BS transmissions), hence, they are in contra-phase and no clicks occur.

$\theta = \pi/2$: No Interference (50/50 Split between $|o_1\rangle$ and $|o_2\rangle$)

$$|s\rangle = \frac{1}{2}(i - 1)|o_1\rangle + \frac{1}{2}(i - 1)|o_2\rangle \quad (\text{Lower half of Figure 5 Bottom-Middle})$$

The photon has equal probabilities to be in each state, so the asterisked detector clicks 50% of the time. The phase of $|o_1\rangle$ is the result of a $\pi/2$ shift in the lower arm (reflection in the first BS) and a π shift in the upper arm (arm's extra length plus reflection in the second BS). Both contributions being in quadrature, the number of clicks in that detector is double the number

obtained when only one arm exists. There is no interference, and the probabilities add directly. This is the analogue of including a non-destructive detector in at least one of the slits (top-middle double-slit diagram). Notice the phase of $|o_2\rangle$ is the result of a π shift (two reflections) in the lower arm and a $\pi/2$ shift in the upper arm (arm's extra length), hence, they are in quadrature as well.

$\theta = \pi$: Destructive Interference for $|o_1\rangle$ (Constructive for $|o_2\rangle$)

$$|s\rangle = 0|o_1\rangle - 1|o_2\rangle \quad (\text{Lower half of Figure 5 Bottom-Right})$$

No photon goes through channel 1 so the detector in channel 2 clicks as many times as the number of single-photon experiments. The phase of $|o_1\rangle$ comes from a $\pi/2$ shift in the lower arm (reflection in the 1st BS) and a $3\pi/2$ shift in the upper arm (extra length plus reflection in the 2nd BS). Both contributions being in contra-phase, no clicks in that detector occur. Notice the phase of $|o_2\rangle$ is the result of a π shift (two BS reflections) in the lower arm and a π shift in the upper arm (extra length), hence, they are in phase and the number of clicks in that detector is double the number when a non-destructive PDI is included (quadruple the number when only one arm exists). Our previous proof of the reality of probable states is hereby further strengthened. Ironically, equating Reality with *Actuality* cannot explain the *actual* data, justifying the century-long philosophical struggle.

3.4 Two Philosophical Enigmas

Two philosophical puzzles have, throughout the last hundred years, incited great minds to issue a cornucopia of anthropocentric claptrap, videlicet: blaming our consciousness for the so-called ‘collapse of the wavefunction’ (Section 4.3); the photon ‘explores all possible paths’; ‘observation destroys interference’; ‘the lack of information for the photon’s path causes interference’, etc. The first conundrum is articulated as: how does the photon ‘know’ beforehand its final *phase* at the detector’s location for every possible path from the source if, *in fact*, it does not go through them? The second enigma can be voiced (using Einstein’s allegorical lingo) as: why the “subtle Lord” seems to be so “malicious” that each time we try to find out which slit the photon *goes* through, *interference* disappears? Per TOPI, both mysteries are the result of our conflating **Reality** with *Actuality*. As we explained, the *actual* is real but **not** everything real is *actual*.

3.4.1 Macro and Micro-Objects as ‘Universe Explorers’

Surprisingly, this ‘mystery’ goes back to the first century AD with the principles of ‘Shortest Path’ (Hero of Alexandria, Optics), ‘Least Time’ (Pierre de Fermat, Optics), ‘Least Action’ (Maupertuis, Optics/Mechanics) and Hamilton’s ‘Stationary Action’ (Mechanics) [19]. Those ‘principles’ are not principles (not even new laws) but alternative *teleological* reformulations of the classical dynamical equations, i.e. *mathematical* expressions intimating that a final purpose (extremizing a certain magnitude) to be realized in the *future* is guiding the *present* behavior of the object – as if the *future* affected the *present* giving the false impression of *retrocausality*. But all laws expressed via differential equations can be redressed as ‘stationary principles’, i.e. we can appropriately conceive a magnitude such that it is always a local *extreme*, also giving the impression that the Universe is ‘intelligently’ pursuing a pre-conceived goal. Unfortunately for all those philosophical stances, the existence of *stationary* principles is true not only for Newton’s equations, but for Einstein’s General Relativity equations, Maxwell’s equations, Schrödinger’s

wave equation, and whatnot. It is a *mathematical* feature of differential equations [24]. Reality and its mathematical description are not the same [19] [3].

Likewise, instead of: ‘the evolution of a macro-object is determined by its initial position and velocity’ we could say: ‘the evolution of the object is determined by its terminal positions and its transit time’. The dynamic equations are such that fixing the initial and final positions, there is only one trajectory joining them in a fixed time – of course if the system stays isolated [17]. Both narratives are equivalent; the former gives us the false impression that the future is not involved at all in what the object does in the present (due to the notion of derivative of a *continuous variable*); the latter brings the future to the fore in the present, giving us the false impression of *retrocausality*. In Classical Physics, the first (Newtonian) narrative is accepted as more realistic – while the second (Aristotelian) is dismissed as merely a *mathematical* feature. So, despite popular belief, this conundrum is not unique to QT.

But what shocks scientists and philosophers alike is that neither of the above narratives is valid in QT: actual trajectory and velocity are emergent concepts valid in our macroworld but ill-defined for a single quanton. We use the macro-concept of alternative trajectories (sequences of ball/pin interactions in the *quincunx*) as a tool to predict the *probability* for a micro-object to transition from a *current* state to a *next* state (Feynman’s path integral). However, *no actual* trajectory exists: all trajectories are probable and made of co-extant probable transitions. We stated when analyzing the *double-slit experiment* that the probability for the photon to reach the detector was “mostly determined” by those ‘trajectories’ around the one for which the transit *R-time* was a local extremum: it is for those ‘trajectories’ that the final disjunctive probable states differ little in phase and interfere constructively (increasing the *probability*) [34] [19]. For a macro-object, such unique trajectory would be actual (joining two locations in a given time-interval); for the quanton, there is *no actual* trajectory between source and detector: the latter simply clicks with a *probability calculable* by integrating all disjunctive probable ‘trajectories’ (sets of all conjunctive probable transitions).

In sum, because of the *teleological* dressing of always-conceivable *stationary* principles, our anthropomorphic mindset plays games with our pretensions to be rational by querying in shock: how *can* any object *know* beforehand which path is the one producing an extreme for the ‘optical path’, ‘time of travel’, Action, etc., unless it *explores* in advance all the infinite possibilities? Our blunder consists in thinking and talking as if the object were *intelligent*. The object, of course, does *not* know what is doing; it simply behaves with a regularity which can be articulated in -among others- a manner which resembles how humans plan their future and conduct their lives. When we design a strategy to attain an objective in the future, the latter is not causing the former: we are using our knowledge of Nature’s regularities to (crossing our fingers) achieve what we desire with a *probability* we consider high enough to justify the effort.

3.4.2 The “Subtle but Not Malicious Lord”

Is ‘The Lord’ really not malicious? We expressed this puzzle as: why the “subtle Lord” seems to be so “malicious” that each time we try to find out which slit the photon goes through, *interference* disappears? The solution again resides in understanding that because it is *directly* accessible to us, *Actuality* is just the unsubtle manifestation of *Reality*. There is more to the latter than what the former directly reveals.

When the non-destructive **PDI**s were inserted in the **double-slit experiment**, the milieu changed: two additional **PI**s were *probable* and, upon firing only one of the (ideal) detectors, *all probable* states for the quanton morphed into a *single actual* state; the situation then became equivalent to the macro-ball in the **quincunx**. For real detectors though, they can fail to fire/not fire, so there are *new probable* states because the final detector now may fire while both intermediate detectors not firing (one of them failing to perform as designed). The latter situation is (for a single quanton) equivalent to the no-intermediate-**PDI**s milieu and, in fact, were both detectors 100% **unreliable**, full interference would show up, with the probability for the final detector to fire oscillating (by changing the slits' separation) between zero and double the sum of the one-slit probabilities. Any failure rate lower than 100% (e.g. avalanche photodiodes are 80% reliable) would show up as a lesser interference in the sense that, when running many single-photon experiments, the maximum number of clicks at the final detector would be larger than zero and lower than double the sum of clicks when opening the slits one at a time.

Succinctly, the *ontic* character of a *probable* state -by its very nature- must be inferred from experimental setups that do not alter its *probable* nature. Understanding our Universe requires direct and indirect evidence – with the latter demanding more inference than the former. Let me insist: no theory with which to infer, no physical magnitude to observe – even if the theory is so simple and ingrained in our being that we deny its existence (as obvious/natural). Einstein was right: “The Lord is subtle but not malicious”. However, ‘The Lord’ is much subtler than what Einstein and Schrödinger could have ever accepted (without the abundant evidence we have now).

4. The ‘Basis’ and ‘Measurement’ Pseudo-Problems

We have shown that abstract states/attributes in **QT/TOPI**'s *Foundation* do have their real counterparts in **QT/TOPI**'s *Ontology*, which are the real states/properties of the assumed real *quantons* [4]. **QT/TOPI** is in utter contrast with other interpretations, e.g. with de Ronde's “Logos Categorical” interpretation [53] in which “there are no systems, no states nor properties involved” [54], all terms of a superposition are “existent in potentiality” [55], and in which “*immanent powers* with definite *potentia*” are the extant “things” [56]. For Rovelli, “Quantum weirdness isn't weird – if we accept objects don't exist” [57] [58]. For others, e.g. the “Statistical Interpretation”, what they call the state of a system “is not a property of the considered system in itself, but it characterizes the statistical properties of the real or virtual ensemble (or sub-ensemble) to which this system belongs... the expression ‘the state of the system’ is doubly improper in quantum physics... although we cannot help to use it in teaching” [43]. Other interpretations relate superpositions to “many worlds” [59] [60] [61] [62], “many minds” [63], or “many histories” [64] [65] [66] [67]; all of them aiming at solving the ‘measurement problem’ and, in the process, facing the “preferred basis problem”.

It is curious to claim an expression is “doubly improper” while asserting “we cannot help to use it in teaching”. **TOPI** takes a diametrically opposed attitude. Inappropriately used words or expressions were either eliminated or redefined, explaining their new specific meaning and, when new concepts required new words, we sensibly created them. *Quantons*, their *states* and *properties* (probable or actual) are ontic – while *superpositions* are only mathematical entities belonging to the *Structure* of **QT/TOPI**, with **no** corresponding real entities in **QT/TOPI**'s *Ontology* [4].

We also explained that the quanton's ontic *current* state encompasses the quanton's reaction to all future **PI**s (contexts) and that our *symbolic* depiction may only include certain types of

states/milieus as a pragmatic (epistemic) necessity. Besides, for all those types of states/milieus that our symbolic depiction does incorporate, the fact that the expression for the *current* state in a given basis points explicitly to the probable *next* states and their probability-amplitudes only for a **PI** whose **MB** is that basis, does not imply that all other milieus (**PIs**) are not included in the ontic state: they are indeed, and recoverable via a unitary transformation of bases in the state-space. Being **QT/TOPI** a theory about the meaning of **QT**, the solution to the so-called ‘basis problem’ will follow directly from **QT/TOPI**’s tenets.

As for the so-called ‘measurement problem’, it is usually articulated as ‘why the measurement of an object in a state of superposition always produces a definite outcome’, or ‘why the measurement produces a single result instead of a superposition of them’ [68], or ‘how the unitary evolution of the state changes to a single eigenstate when an observation is made’. Besides dogmatically accepting **Schrödinger’s Equation** as universally valid, all these utterances presume a quantum object can be in a ‘state of superposition’, which leads some to wonder why when playing Russian roulette and surviving we only remember being alive! My mind cannot imagine what a ‘superposition’ as a measurement result or remembering being in a superposition could mean. So presented, the ‘problem’ will be easy to solve within **QT/TOPI**. There is a different query though, also referred to as the ‘measurement problem’, which -properly reformulated- poses a real and interesting puzzle.

4.1 **QT/TOPI’s Resolution of the so-called “Preferred Basis Problem”**

It is a commonplace in the literature to state that **QT** offers no rationale for the **infinitude** of possible bases in terms of which the quanton’s state can be represented as a superposition, that these bases are “incompatible”, and that we are compelled to choose one ‘preferred’ basis for each experimental situation (context). This basis is sometimes referred to as the “basis which gets actualized” [69]; it is also asserted that a superposition “is not reducible to one single state, and there is no obvious interpretation of such superposition” [70]. Hence, many authors conclude that those numerous representations cannot describe a single physical reality, attempting to resolve the matter by postulating that only one basis is physical, e.g. Bohm’s position basis [71], Dieks’ Schmidt’s basis [72] [73] [74], the ‘stable under environmental decoherence’ basis [59], or the basis obtained via ‘environmentally induced selection’ [75].

Our detailed description and application of **QT/TOPI** to a variety of physical situations allow us to close the subject matter in a few paragraphs. The **MB** is undoubtedly an epistemically preferred basis though certainly **not** an *actual* one: were the current state (*probable* or *actual*) not in **MB**, and the **PI** a **PTI**, **no** next state would be *actual*, let alone could the basis to which it belongs be. Ergo, to assign ontology (actual or probable) to a mathematical superposition and not to the others is unwarranted – even if it is assigned to the one obtained via the **MB**. The *current* state is **ontic** and, for a given **PI** (milieu), the states in the **MB** are co-extant **ontic** probable *next* states until the quanton undergoes a **PDI**, upon which only one of them becomes actual. However, all representations of the current state via superpositions of eigenstates in all possible bases are *epistemically* equivalent mathematical entities.

The fact that there is -for each **PI** experienced by a quanton in a pure state- one basis in the state-space for which Born’s Rule (as such) is directly applicable, does not constitute a ‘problem’ but an epistemic blessing. It is only natural that the quanton’s evolution may depend on its state plus its milieu and, in most cases, the milieu alone determines the quanton’s probable *next* states.

The milieus corresponding to noncommutative operators (properties) are *epistemically incompatible*, but they are *ontically compatible* because all milieus are encompassed by the quanton’s *ontic* state. That is what the idea of ‘state of an entity’ conveys in its most intuitive meaning (even for us humans when we talk about our ‘state of body/mind’). Besides, for a given *ontic* current state and milieu, the transition **PD** is *ontic* and **basis-invariant**, so all representations (superpositions) do describe the same Reality.

Closing: the so-called ‘Preferred Basis Problem’ is misguided; under **QT/TOPI**, all bases are legitimate regardless of state and milieu. For each milieu, the **MB** is preferred for the same reason that decomposing the gravity force along the rod and its perpendicular directions is preferred for the **pendulum** (it facilitates the application of Newton’s gravity and motion laws). Of course, the separate problem of determining the **MB** for each **PI** does remain. We saw how the physical designs of **PFs**, **BSs**, **PBSs**, and **SG** magnets singled out their **MBs**, making it clear that this problem is specific to each **PI** and neither is part nor lessens the verisimilitude of **QT** – in the same way that the problem of determining the specific classical Hamiltonian for each **PI** (e.g. **Equations 3/top-left** for the pendulum) is neither part nor lowers the validity of Hamiltonian **Equations 3** (top-middle/right). Furthermore, from above, bases are not physical entities and, ergo, there cannot exist a dynamic process in **RT**-spacetime that selects or leads to one basis instead of another.

Before facing the so-called ‘Measurement Problem’, we need to further discuss “some sort of ultimate quasi-religious truth”.

4.2. The Temporal Schrödinger’s Equation

I could not agree more with Nicolas Gisin when he said in [12]:

Apparently, the many followers of today’s trend elevate (unconsciously) the linearity of the Schrödinger equation and the superposition principle to some sort of ultimate quasi-religious truth, some truth in which they believe even more than in their own free will.

Schrödinger conceived his famous (non-relativistic) wave equation as a hybrid that integrated Classical Wave Theory with Planck/Einstein/de Broglie’s quantic innovative relations between frequency and energy and between wavelength and momentum. These relations made possible the so-called ‘quantization’ process, which transcribes a classical particle equation into a quantic wave equation (i.e. containing Planck’s constant h). Pauli completed the equation by including his three famous spin matrices and the external magnetic field into the Hamiltonian. This non-relativistic Schrödinger-Pauli equation predicted correctly the non-zero magnetic moment of the hydrogen atom, all the Stern-Gerlach results, and the Anomalous Zeeman Effect [3] [24].

However, such an equation could not be more than an approximation valid only when the underlying hypotheses were good enough and when describing akin physical situations. Even so, because its application quickly scored many successes with considerably less calculation efforts than the equivalent Matrix Mechanics, the Copenhagen’s school adopted it – though with the probabilistic interpretation proposed by Max Born. That is why it has survived the test of time as an abstract tool while gradually becoming a “quasi-religious truth”. Reality is that, even today, nothing but empirical success justifies its validity [24] [36] [76] [3].

Regardless of which the **MB** = $\{|m_k\rangle\}$ for the **PI** is, the temporal Schrödinger’s Equation rules the dynamics of the quanton’s state via the Hamiltonian Operator \mathcal{H} , whose eigenvectors define

the Hamiltonian Basis (HB). Assuming there is a realistic Hamiltonian which does not depend explicitly on time (the quanton is in a conservative field), Schrödinger's Equation and solution are:

$$i\hbar \frac{\partial}{\partial t} |s(t)\rangle = \mathcal{H} |s(t)\rangle \Rightarrow |s(t)\rangle = e^{-\frac{i}{\hbar} \mathcal{H} t} |s_0\rangle \Rightarrow |s(t)\rangle = \sum_{k=1}^n \langle E_k | s_0 \rangle e^{-\frac{i}{\hbar} E_k t} |E_k\rangle \quad (17)$$

First and second **Equalities 17** are equation and solution in operator form; third equality expresses the solution in the Hamiltonian (Energy) basis $HB = \{|E_k\rangle\}$, where $|E_k\rangle$ and E_k are respectively the (assumed discrete for simplicity) eigenvectors and eigenvalues of \mathcal{H} – which are solutions of the time-independent Schrödinger's Equation: $\mathcal{H} |s\rangle = E |s\rangle$. The Hamiltonian Operator \mathcal{H} may be obtained by heuristically transforming the classical magnitudes in the classical Hamiltonian $H(q, p)$ into Hermitian operators via the conversion key: $p^n \rightarrow (\hbar/i)^n \partial^n / \partial^n q$, a process which may or may not be successful. Evidently, even if we ignore Born's subsequent probabilistic interpretation, the foundation for this iconic equation is quite precarious.

The quanton/milieu interaction that Schrödinger's Equation governs is a type of **PTI**, viz no **PDI**s are involved though, of course, the latter are needed to test the equation's validity vis à vis **Reality**. Much of the conceptual confusion surrounding Born's stochastic interpretation of **Equations 17** exists because they rule the deterministic infinitesimal transition from a single previous state $|s_0\rangle$ (actual or probable) to a single current probable state $|s(t)\rangle$, the latter being expressed in terms of its many probable next states in a single milieu characterizable by \mathcal{H} . Pithily: when valid, Schrödinger's Equation rules the evolution of the current state or, equivalently, of the probability-amplitudes for **all next probable** energy states (the energy's **PD**), while the quanton/milieu system remains closed. But if $|s_0\rangle$ is not actual (and if it is -without a **PDI**- any of the next states will be not), Equation 17/right conveys not one but n superpositions because $|s_0\rangle$ can be any of the n eigenstates in the previous **MB** (the probable states for the previous **PI**) so it conveys n^2 probable transitions – like **Equations 6 (BS)** and **7 (PBS)** regulate four probable transitions in a 2-D state-space. Thus, per **QT/TOPI**, Schrödinger's Equation governs the unitary temporal evolution of all probable states from a given initial state. As with the **quincunx** in the 'Schrödinger's picture', it is the current state the one to which an **R-Time** can be assigned, while the Hamilton Operator remains the same; instead, the adjective 'next' before 'state' refers to **QR-Time**, i.e. to all the probable states in the Hamiltonian Basis: until a **PDI** occurs, the current state evolves in **R-Time** but it is separated from its next states in **QR-Time** (Part IV [1]).

As always, the equation's verisimilitude can only be tested via the statistical analysis of many equivalent runs, all characterized by the quantic system with the same initial actual state $|s_0\rangle$ (achieved via a **PDI** at the **R-Time** t_0), the same milieu, and the same elapsed **R-Time** set via a second **PDI** at the **R-Time** t – each run delivering one of the probable states $|E_k\rangle$ as an actual state with the energy E_k . The ratio between the actual number of times each of the probable states is obtained and the actual number of runs should agree in the limit with the probabilities predicted for each one of them. The **R-Time** interval between $|s_0\rangle$ and $|s(t)\rangle$ actual states can be as narrow or wide as experimentally possible while retaining quantic behavior (Part IV [1]). By changing the second **R-Time**, the temporal evolution predicted by Schrödinger's Equation can be fully tested.

Equations 17 (left and middle) tell us that the transition from the pure state $|s_0\rangle$ towards any future pure state $|s(t)\rangle$ is governed by the operator $\mathcal{U}(t) = \exp[(-i/\hbar)\mathcal{H}t]$, which is unitary

($UU^\dagger = \mathcal{J}$). The 2-superposition in **Equations 17** (right) tells us that the initial expansion of the quanton's state in HB changes in **R-Time** by simply multiplying each component by the phase factor $\exp[(-i/\hbar)E_k t]$. Thus, the components' phases evolve in **R-Time**, but their moduli do not. Ergo, if MB = HB, then the components are the probability-amplitudes for the next probable energy states, Born's Rule applies, and the energy's **PD** does not change with **R-Time**. It is the energy **PD** (not the specific energy values) that is conserved, which is consistent with **QT/TOPI**'s tenet that the **PD** for a physical attribute (not its values) is the *ontic* property of a quanton. And, if a property \mathcal{P} commutes with \mathcal{H} , because all powers of \mathcal{P} also commute with \mathcal{H} , all moments of the **PD** for \mathcal{P} are **R-Time**-independent – e.g. for the first moment: $d\langle\mathcal{P}\rangle/dt = \langle[\mathcal{P}, \mathcal{H}]\rangle/i\hbar = 0$. Ergo, the property \mathcal{P} is also conserved.

We also see that: a) as it must be: $\| |s(t)\rangle \| = 1 \forall t$; b) if $|s_0\rangle = |E_k\rangle$ for some k , then $|s(t)\rangle = \exp[(-i/\hbar)E_k t]|s_0\rangle \equiv |s_0\rangle$, so the ontic state does not evolve in **R-Time**; c) if $|s_0\rangle$ comprises two or more eigenstates, it could not morph into only one eigenstate; and d) though the relative phases do evolve in **R-Time**, they do not disappear, so a *pure* state does not decohere, i.e. it remains *pure*. These features clearly explain why Schrödinger's Equation cannot govern a **PDI**.

If MB \neq HB (i.e. if $[\mathcal{H}, \mathcal{P}] \neq 0$), we obtain the state's evolution in **MB** by transforming the solution in HB (**Equation 17/right**) into its expression in **MB**. After doing so, Born's Rule can be applied to each component, obtaining the evolution for the state-transition **PD** for \mathcal{P} . Calling \underline{s}_H and \underline{s}_m the column state vectors in bases HB and **MB** respectively, and using **Equations 8** for the transformation of bases, we get:

$$\begin{aligned}
|s(t)\rangle &= \sum_{k=1}^n \langle E_k | s_0 \rangle e^{-\frac{i}{\hbar} E_k t} |E_k\rangle &\Rightarrow & \underline{s}_H(t) = \begin{bmatrix} \langle E_1 | s_0 \rangle e^{-\frac{i}{\hbar} E_1 t} \\ \vdots \\ \langle E_n | s_0 \rangle e^{-\frac{i}{\hbar} E_n t} \end{bmatrix} \\
& & \Downarrow & \\
\underline{s}_m(t) &= \begin{bmatrix} \langle m_1 | E_1 \rangle & \cdots & \langle m_1 | E_n \rangle \\ \vdots & \ddots & \vdots \\ \langle m_n | E_1 \rangle & \cdots & \langle m_n | E_n \rangle \end{bmatrix} \begin{bmatrix} \langle E_1 | s_0 \rangle e^{-\frac{i}{\hbar} E_1 t} \\ \vdots \\ \langle E_n | s_0 \rangle e^{-\frac{i}{\hbar} E_n t} \end{bmatrix} = \begin{bmatrix} \sum_{j=1}^n \langle m_1 | E_j \rangle \langle E_j | s_0 \rangle e^{-\frac{i}{\hbar} E_j t} \\ \vdots \\ \sum_{j=1}^n \langle m_n | E_j \rangle \langle E_j | s_0 \rangle e^{-\frac{i}{\hbar} E_j t} \end{bmatrix} \\
& & \Downarrow & \tag{18} \\
|s(t)\rangle &= \sum_{k=1}^n \langle E_k | s_0 \rangle e^{-\frac{i}{\hbar} E_k t} |E_k\rangle = \sum_{k=1}^n \langle m_k \left\{ \sum_{j=1}^n \langle E_j | s_0 \rangle e^{-\frac{i}{\hbar} E_j t} |E_j\rangle \right\} |m_k\rangle
\end{aligned}$$

The last line in **Equations 18** shows the ontic state expressed in both bases and, clearly, the components' moduli in **MB** do change with **R-Time** so the **PD** for any property whose operator does not commute with the Hamiltonian does evolve. Now: a) $\| |s(t)\rangle \| = 1 \forall t$ as it should; b) if $|s_0\rangle = |m_k\rangle$ for some k , then $|s(t)\rangle = \langle m_k \{ \sum_{j=1}^n \langle E_j | m_k \rangle \exp[(-i/\hbar)E_j t] |E_j\rangle \} |m_k\rangle$ so, unlike for the 'MB = HB' case, the quanton's state does evolve; c) if $|s_0\rangle$ comprises two or more eigenstates,

like for the 'MB = HB' case, it could not morph into only one eigenstate; and d) as for the 'MB = HB' case as well, relative phases do evolve in **R-Time** without decoherence, i.e. the state remains *pure*. We conclude again that Schrödinger's Equation cannot govern any **PDI**.

4.3 QT/TOPI's Resolution/Reformulation of the so-called 'Measurement Problem'

We saw in Parts I and II of this series that the term 'measurement' in the literature does not correspond to the conventional meaning of the word. We created the locution 'Gauge Interaction' (**GI**) to replace 'measurement' and pointed out that, in **QT**, only when the current state is *pure* and belongs to the current **MB**, the quanton's state does not change and the **GI** becomes a 'True Measurement' (**TM**). Recklessly considering **GI**s (needed to assess quantum phenomena) as full-fledged conventional measurements is one of the reasons behind the hogwash surrounding the 'Uncertainty Principle' and the so-called 'measurement problem'. We are collecting experimental data related to the interaction between the quanton and its milieu, but we cannot assert that such data always allow us to infer what the state of the quanton was before the interaction (as we can with an ordinary measurement).

By a poor choice of words (not unusual in Science), Dirac inaugurated in 1930 the infamous (still among us) 'collapse of the wavefunction' when he said (underscore is mine):

DIRA1: *When we make the photon meet a tourmaline crystal, we are subjecting it to an observation. We are observing whether it is polarized parallel or perpendicular to the optic axis. The effect of making this observation is to force the photon entirely into the state of parallel or entirely into the state of perpendicular polarization. It has to make a sudden jump from being partly in each of these two states to being entirely in one or the other of them. Which of the two states it will jump cannot be predicted, but is governed only by probability laws. [77]*

Though tacitly, Dirac implies that the photon is detected (via some **PDI**), so there is more to Dirac's statement than the **PTI** a photon experiences when meeting a crystal. In the light of **QT/TOPI**, the conceptual mistakes in **DIRA1** are: (a) when a photon meets a tourmaline crystal we are not "observing whether it is polarized parallel or perpendicular to the optic axis"; (b) the **GI** (**PTI+PDI**) with the crystal does not "force the photon entirely into..."; and (c) the actual state transition ("jump") the photon experiences upon detection is not from "being partly in each of these two states to being entirely in one or the other of them". Mathematical depiction and Reality are not the same. The latter is out there and unique, the former is created by us and admits multiple interpretations – even when it perfectly agrees with experimental data.

Regarding (a), unless the *current* state is in the **MB** determined by the crystal, the actual *next* state is not the same, so the **GI** is not a **TM**. As for (b), the photon's *current* state could be already one of the two probable *next* states and the **GI** would be a **TM**. Concerning (c), during the **PTI** part of the **GI** (before detection) the *current* state comprises two probable *next* states (the ones in the **MB**); upon detection (the **PDI** part), the actual transition ("jump") is from a *single* state (the *current* state) to a *single* state (the *next* actual state) – via the conversion into actual of *one* of the probable states or, equivalently, by only one of the two probable transitions becoming actual. Which one of the two is actualized (both were real already) is stochastically governed by the ontic **PD** determined by the *current* state and the polarization property operator (**Equations 10** for the **PD** moments).

Unfortunately, by taking **DIRA1** literally, the question about the specific nature of such a weird physical 'jump' from "being partly in each of these two states to being entirely in one or the other

of them” and the supposedly need for the mathematical ‘collapse’ of the wavefunction appeared on stage. In 1932, von Neumann, in his famous *Mathematical Foundations of Quantum Mechanics*, introduced the idea of the ‘wavefunction of the Universe’ and gave credibility to the incipient ‘measurement problem’ with his formal introduction of the ‘projection postulate’. He also stated that the quantum state could change via two fundamentally different processes that he set apart with the vague notion of ‘measurement’: between ‘measurements’ the quantum object evolved deterministically ‘in time’ (continuously, linearly, and reversibly); upon a ‘measurement’ the change of the state was stochastic, discontinuous, and irreversible, i.e. with a ‘collapse’. Not realizing that probability was embedded in the deterministic evolution governed by **Schrödinger’s Equation** (per QT/TOPI, any equation governing a PTI), chance was exclusively assigned to the ‘measurement’ process (whatever that was) and, inexplicably, a theory supposed to be about **Reality**, became a theory about the anthropic ‘measurement’. To convolute matters, von Neumann argued that the ‘collapse’ could be placed anywhere between the measuring device and the deeply mysterious consciousness of ours.

The official birth certificate for the ‘measurement problem’ was stamped by EPR and Schrödinger’s papers [2] [10] [8] [9] [6], after which the peculiar phenomenon of *entanglement* was labeled as the hallmark of -and a sine qua non for- every physical interaction. And, given that nobody knew what a ‘measurement’ was, the quantum object supposedly got *entangled* with the ‘measuring’ device, which supposedly was *entangled* with the environment, which supposedly was... moving the supposedly *stochastic* ‘collapse’ via an infinite progression towards the ‘supreme’ being: the ‘observer’ (as intimated by von Neumann). And, until reaching this mighty ‘collapsor’ (capable of stopping further entanglement), **Schrödinger’s Equation** was the *entangler* par excellence and ruled the quantum (micro and macro) world by despotic fiat. Joining von Neumann, Eugene Wigner, Fritz London, and Edmond Bauer became believers, with Wigner still defending such a stance as late as in the early 1990s. Alternatively, other equally intelligent thinkers believed (with adherents now steadily growing) that the ‘collapse’ is only *apparent* because the rest of the states in the superposition do also ‘occur’... though in other never-to-interact-again worlds [59] [60] [61] [62]. We already mentioned other proposals [54] [55] [56] [43] [63] [64] [65] [66] [67].

4.3.1 Common Articulation of the ‘Measurement Problem’

As said, the ‘measurement problem’ is usually articulated as ‘why the measurement of an object in a state of superposition always produces a definite outcome’ or ‘why the measurement produces a single result instead of a superposition of them’. However: (a) what does it mean for a quantum object to be in a state of superposition? And (b) what does it mean for a ‘measurement’ to produce a superposition? Nobody could answer (a), except by pointing to the mathematical expression itself – while timidly but mystically implying the object was in all those actual states ‘at once’. Likewise for (b), though Louis de Broglie’s had conjectured in the late 1920s that when two monochromatic waves were superposed and intensity-dimmed, the single photon would have an energy somewhere between those of the two waves (determined by their frequencies) so that, upon photoelectricity manifesting in our RT-spacetime, electrons with intermediate energies would emerge. But he quickly recanted because Millikan in 1914 had confuted such an idea with accurate experimental data (disgruntledly confirming Einstein’s predictions).

From above, the question that has survived till today is ‘why the measurement of a quantum object in a state of superposition always produces not some combination of the superposed states

but one of them as a definite outcome’. Furthermore, it was implicit that an acceptable answer had to involve a physical ‘mechanism’ to convert ‘a superposition’ into ‘a single value’ (the infamous ‘collapse’) – something we proved **Schrödinger’s Equation** (the supposedly universal entangler) cannot do. Many researchers then conceived spontaneous localization (position collapse) theories (GWR theory [78] [1]), modifications of **Schrödinger’s Equation** to include the collapse via nonlinear stochastic differential equations [79] [80], and combinations thereof [81] [82] [83].

Another ‘mechanism’ to explain the appearance of a ‘collapse’ was *Decoherence*, tacitly existing in Bohm’s well-known hidden-variable theory (1952) and in Everett’s also well-known MWI (1957). It became popular in the 1980s and remains so today. The fallacious underlying premise is that any interaction between a quanton and its global milieu (‘measurement’ apparatus plus its macro-environment) quickly results in the quantic entanglement between the two, i.e. that the composite system is in a quantic *pure* state and the quanton as well as the ‘apparatus plus environment’ are in *co-states* (*mixed* states in the literature). In brief, the dynamics of the whole is unjustifiably assumed unitary (2-superpositions) and, from what we learned for the **EPRB** composite of two qubits, both the quanton and its macro-environment are expected to behave non-unitarily (**convex** superpositions) losing quantic coherence while remaining correlated. Hence, *decoherence* at most could explain the transition of the ‘measured’ quanton from its presumed *pure* state to a mixture of states that correspond to the possible ‘measured’ results: all *decoherence* could do is to destroy phase coherence of the quanton’s *current* pure state, leaving intact all its *next* probable states, viz with **no** infamous ‘collapse’ of the wavefunction. Combined with unitary dynamics, *decoherence* has also been used to unsuccessfully derive the macroworld straight from the (presumably universal) quantum laws of the microworld [84] [75] [43].

But, under **QT/TOPI**, a ‘measurement’ (our **GI**) comprises at least one **PDI**, which is nonlinear and irreversible, so Schrödinger’s (or Dirac’s) Equation cannot govern such a **PI**. If the **PI** does include a **PDI**, the transition to an *actual* state occurs from the *current* state to **one** of the probable *next* states, i.e. from a *single actual* or *probable* state to a *single actual* state – not ‘from a superposition of states to a single state’ as popularly stated. Whether those two states are (given a basis) mathematically represented via a superposition or not is irrelevant: the physical state is **not** a superposition per se; its mathematical *representations* are (some are not).

Consequently, the so-called “measurement problem”, as usually stated, is a pseudo-problem because the premise is false. The eigenstates in the superposition elicited by the **MB** represent ontic probable states, not actual states. The expression “the system **is** in a superposition of states” has **no** physical meaning; the quanton is in a well-defined actual or probable ontic state which can be symbolically depicted in infinite ways. Superpositions are mere *mathematical* depictions of an *ontic* state. The *current* milieu (i.e. the type of **PI**) determines the *current* **MB** or, equivalently, the transformation to be applied to the *previous* **MB** so that the new probable *next* states are exposed and their **PD** (**not** their values) determined by Born’s Rule. If one of the *next* states becomes *actual* (after a **PDI** on an *actual* or a *probable* state), then of course we experimentally see only one state; otherwise (upon only a **PTI**), all *next* states are probable and the number of them depends upon the current **MB** (from one eigenstate up to the dimension of the space).

Closing, this pseudo-problem is the result of conflating (a) Reality with Actuality and (b) the quanton with its states. Per **QT/TOPI**, those states appearing in the superposition obtained using the **MB** are real but not actual; and there are physical interactions (**PDIs**, mostly non-anthropoc) that convert all those probable states comprising the quanton’s *current* state into one actual *next*

state. The **PDI** uncovers the *ontic* character of probability by partially manifesting it in our **RT**-spacetime with (of course) only one actual state and values for the properties compatible with the **MB** (Section 3). States are dynamic *features* of the quanton, so they come and go with its evolution. Hence, there is need to conceive neither a physical nor a metaphysical “collapse” process that would purportedly convert many (allegedly actual but they are not) states into a single actual state.

4.3.2 Reformulation of the ‘Measurement Problem’ in the Light of QT/TOPI

Seemingly against our stance, in 2017, Gisin stated that the ‘measurement problem’ was a “serious physics problem” – though he wisely articulated it as: “What configuration of atoms and photons characterize measurements setups?” [12]. The reason this variant is still referred to as the ‘measurement problem’ is because by ‘measurement setup’ it is (misleadingly) understood any physical arrangement that leaves records in our **RT-spacetime** (whether it is a measurement in the conventional sense or not) and, in all such cases, the alleged ‘collapse’ is supposed to occur. But asking why and how a hypothetical ‘collapse’ occurs (prevalent articulation) is different from asking what type of experimental setup displays what is referred to (correctly or not) as ‘a collapse’.

So presented by Gisin, even with the vague “measurements setups”, and assuming there are setups that are not ‘measurement setups’, this variant of the ‘measurement problem’ is a different, valid, important, and thought-provoking conundrum. Reformulated in non-anthropocentric terms vis à vis **QT/TOPI**, it consists in understanding when a **PI** is or includes a **PDI**. However, as such, it is not part of **QT** per se (at least not of what we call **QT** today) and will be tackled in future papers. For now, let us elaborate a little further about the traits of a **PDI** as opposed to those of a **PTI**.

George Ellis asks why photodiodes or chlorophyll in plants’ leaves do not behave reversibly or simply why they do not emit light rather than absorbing it. He thinks the answer must be in the anisotropic spatial structures those systems define jointly with the local context plus their initial conditions – leading to nonlinear irreversible behavior. He concludes that “we have no evidence that the universe as a whole behaves as a Hamiltonian system” [85]. I would say there is plenty of evidence it does not. Barbara Drossel gives “Ten reasons why a thermalized system cannot be described by a many-particle wave function” [13]. They, as co-authors, explain in [14] why, despite abundant experimental proof of macroscopic entanglement, **QT** is not universally valid (underscore is mine):

Such situations are attained only by sufficiently isolating the system from interactions with the rest of the world, and in particular from interaction with heat baths. This requires low temperatures, or, in the case of long-distance entanglement experiments, time scales that are shorter than the characteristic time for interaction with a heat bath. This is in total contrast to the measurement process, where interaction with the heat bath is the core of what is happening.

And, regarding the ‘heat bath’ (essential component of a **PDI**), they explain why its evolution cannot be unitary (and ergo its interaction with the quanton cannot be a **PTI**):

Due to the emission of photons a fully quantum mechanical description of the heat bath by unitary time evolution would need to include an ever increasing entanglement with the external world. Claiming that such a unitary time evolution occurs nevertheless has no basis in physics as an empirical science. The wave function of the heat bath plus environment can neither be controlled nor measured, not even in principle... The thermal time and length thus describe the temporal and spatial range over which quantum coherence occurs... Only the electron can

be described by a wave function, not the combined system... Moreover, it is experimentally completely unrealistic to assume that the apparatus has been initially prepared in a pure state.

Clearly, despite the quanton interacting with macro-objects, the ITIs among the quanton's probable states in PTIs occur either within the microcosm or, under exceptionally extreme and controlled situations, within the macrocosm, e.g. a SQUID superconductor macro-ring. In any case, always with extreme isolating techniques to minimize decoherence phenomena. In sum, *linearity* in the macroworld may emerge from *linearity* in the microworld but it is the conspicuous exception, with *nonlinearity* being the rule [44] [86] [87]. PDIs (necessary for a quanton to leave a record in our RT-spacetime) are inherently *nonlinear* (nonunitary) and *irreversible* (dissipative) – rendering *Schrödinger's Equation* (or equivalent) useless.

Wrapping up, the detection/amplification process in a PDI creates a macro-state for the milieu (correlated to the quanton's state) and does occur in RT-spacetime, but it is highly specific to the PDI and -if anthropic- to our detection instrumentation [3] [88]. The prevalent idea that QT provides per se a theory of 'quantum measurement' is as nonsensical as to affirm that Classical Physics provides a theory of 'classical' measurement. Observation and measurement are crucial for theory validation but do not belong to a fundamental theory because every measurement is specific to the physical property being measured and based on its own specific theory [4] [5] [88].

5. Schrödinger's "Hellish" Machine

Schrödinger's satire of QT highlights the following elements: a) a living cat locked up in a room with opaque walls; b) a tiny piece of radioactive material; c) a causal macro-mechanism comprising a Geiger counter, a relay, a hammer, and a fragile container of prussic acid; d) leaving the entire contraption alone for an hour, within which there is 50% chance for an atom of the radioactive material to decay and trigger the causal chain in RT-spacetime – leading to the demise of the unfortunate cat; and e) the groundless hypothesis that the whole contrivance can be mathematically represented by a ψ -function (a *pure* state) which he, right before opening the enclosure, sarcastically interprets as a "mixture of a living and a dead cat". We start by understanding what radioactivity is and how is mathematically described and explained.

5.1 Nuclear Decay/Atomic Radiation vis à vis QT/TOPI

The Curies concluded that the intensity of radioactivity did not depend on the element's chemical form, ambient temperature, pressure, near electromagnetic fields, illumination, what have you; only the type and number of atomic nuclei determined the radiation intensity. They said: "Radioactivity is an atomic property... its spontaneity is an enigma; a subject of profound astonishment". The nucleus decay process is also a QEI because, upon decay, the nucleus emits a 'radiated' quanton(s) (α , β or γ 'rays') by the detection of which (a PDI), Rutherford found that equal fractions of the nuclei population disintegrated in equal times, with a decay rate characteristic of the chemical element. The how and when for the disintegration of a single nucleus was not predictable, but the statistical behavior of a large population was. The Curies' *spontaneity* was quantified as the *statistical* property of a large population and, hence, creeping down to a single nucleus with the notion of *probability*. Atomic spontaneous/stimulated emissions behaved equally. Nuclear disintegration and atomic radiation are sheer stochastic processes [19].

Under QT/TOPI, the relation between Statistics and Probability is reversed: each nucleus has a characteristic ontic probability to decay, which is the reason for (not the result of) the persistent

relative frequencies in long sequences of detected decay events. Calling N_0 the initial number of undecayed atoms and $N(t)$ the number of undecayed nuclei at **R-Time** t , and (to apply Calculus) letting $N \rightarrow \infty$ and $\Delta t \rightarrow 0$, Rutherford's "equal fractions in equal times" becomes the differential equation $dN/dt = -N/\tau$, with the constant τ characteristic of the radioactive element [19]. Its solution is: $N(t) = N_0 e^{-t/\tau}$. This function thus governs the time evolution of an ensemble of atoms and, by the Law of Large Numbers, the **R-Time** for a single disintegration event (decay) is a random variable $T \in [0, \infty)$ whose probability density distribution is $d_T(t) = 1/\tau e^{-t/\tau}$. Ergo, the following probability equations for the nucleus disintegration can be established:

$$\begin{aligned}
 \Pr\{0 \leq T \leq t\} &= \int_0^t 1/\tau e^{-t'/\tau} dt' = (1 - e^{-t/\tau}) \Rightarrow \Pr\{T > t\} = e^{-t/\tau} \\
 &\Downarrow \\
 \Pr\{t \leq T \leq t + \Delta t\} &= \int_t^{t+\Delta t} 1/\tau e^{-t'/\tau} dt' = e^{-t/\tau} (1 - e^{-\Delta t/\tau}) \quad (19) \\
 &\Downarrow \\
 \Pr\{[t \leq T \leq t + \Delta t]/[T > t]\} &= \frac{\Pr\{t < T \leq t + \Delta t\}}{\Pr\{[T > t]\}} = (1 - e^{-\Delta t/\tau})
 \end{aligned}$$

Equation 19 (top left) presumes the nucleus has been set (via a natural or anthropic process) in a metastable state at $t = 0$. It tells us that the probability of decay increases exponentially with **R-Time**, approaching unity as $t \rightarrow \infty$. Equivalently (top right), the probability for not decaying decreases exponentially with **R-Time**. **Equation 19** (middle line) quantifies the probability for the decay event to occur within the interval $t \leq T \leq t + \Delta t$ (Δt -interval at time t). It says that the longer the time horizon t , the lower the probability is that the atom will decay within a given Δt -interval after it, simply because the higher the probability is that the event may occur before.

Equation 19 (bottom) assumes that $T > t$, i.e. that the nucleus has not decayed during the interval $[0, t]$. We see that the conditional probability becomes only dependent upon the size Δt of the time interval (not upon **R-Time** per se). The nucleus seems not to have 'memory' and not to 'age'. This is in stark contrast with the macroworld (where things and humans do age). Note again that the probability for the nucleus to remain undecayed ('survive') decreases monotonically with the elapsed **R-Time** (**Equation 19**/top right). The conditional probability for decaying within Δt is the same as **R-Time** passes, but the probability for such condition ('survival') decreases with time.

It is straightforward to prove that τ is both the Mean $\langle T \rangle$ (*lifetime* or *mean life*) and the **SD** of the distribution for decay times. For instance, the lifetime for Uranium-238 is 6,500 million years; for Radon only 5.5 days; and for the Muon just 2,200 nanoseconds. From **Equation 19** (top left), we see that τ is also the time for which the probability of decaying before it is $1 - e^{-1} = 0.632$. Statistically, after time τ , out of a large sample of radioactive material, 63.2% of the nuclei will have decayed. Oftentimes the term *half-life* ($\tau_{1/2}$) is also used, which is the time for half of the population to decay. They are related by $\tau_{1/2} = (\ln 2)\tau$. The case imagined by Schrödinger in **SCHR1** could correspond approximately (there were of course many atoms in his "tiny amount") to some of the highly radioactive isotopes of Neptunium (Np), with a half-life around 50 minutes or less. Let us now look at **Equations 19** through the orthodox **QT** formalism.

5.2 Quantic State Transition for the Nucleus

We call $DP = (1 - e^{-\Delta t/\tau})$ the ‘ageless’ conditional probability of Decaying (‘Dying’) and $SP = (1 - DP) = e^{-\Delta t/\tau}$ that of not decaying (‘Surviving’) within Δt . From [Equations 19](#) (middle line), the probability to die within Δt starting at time t is the probability $e^{-t/\tau}$ to survive until time t times the probability DP to ‘die’ within Δt . Note it is the probabilities that are directly multiplied. Let us discretize time so that $t = k\Delta t$; $k = 0, 1, 2, \dots$. Rewriting [Equations 19](#) we get:

$$\Pr\{k\Delta t \leq T \leq (k+1)\Delta t\} / [T > k\Delta t] = DP ; \Pr\{T > (k+1)\Delta t\} / [T > k\Delta t] = SP \quad (20)$$

$$\Pr\{k\Delta t \leq T \leq (k+1)\Delta t\} / [T \leq k\Delta t] = 0 ; \Pr\{T > (k+1)\Delta t\} / [T \leq k\Delta t] = 0$$

Where $k = 0$ corresponds to when the nucleus adopted its metastable state. Being $t = k\Delta t$, the Δt -interval moves with k , defining a grid of *actual* states/times – as we did with the [quincunx](#). The nucleus can be in one of two *actual* states at $t = k\Delta t$: the metastable ‘Not Decayed’ or the stable ‘Decayed’. If in the former, it may decay within Δt with probability DP and may survive with probability $SP = 1 - DP$ ([Equations 20](#) top); if in the latter, no further change may occur ([Equations 20](#) bottom).

The decay event is an internal [PI](#) *spontaneously* experienced by the nucleus. Dogmatically following the [QT](#) formalism, the actual metastable state the nucleus is in before decaying could be expressed as a superposition of two probable next states: ‘Not Decayed’ (ND) and ‘Decayed’ (D). The actual decay event can occur at any [R-Time](#) $t = k\Delta t$ so, for each k , the nucleus is in a well-determined (*actual*) state: either in the original metastable (undecayed) state or in the ‘decayed’ stable state. By reducing Δt , the [R-Time](#) resolution could be made as high as experimentally possible so, like for the [quincunx](#), the probable status of those two states would be limited to a vanishingly narrow [R-Time](#) interval outside of which the decay event would happen or not. Per [QT/TOPI](#), though ephemeral, the two probable next states would be real, coexisting as ‘determining parts’ of the *current* state. The question now is whether the proposed superposition is a 2-superposition (like for a [pure state](#)) or a 1-superposition (convex like for the [quincunx](#)’s ball), namely:

$$|s\rangle = s_1|ND\rangle + s_2|D\rangle ; s_1s_1^* = SP ; s_2s_2^* = DP \quad \text{or} \quad [s] = SP[ND] + DP[D] \quad (21)$$

But the decay process is quite singular because, per Curie’s finding, the milieu does not single out any [MB](#), so our choice of basis ($\{|ND\rangle, |D\rangle\}$ or $\{[ND], [D]\}$) seems to be quite arbitrary and unaffected by any milieu manipulation. Until the nucleus decays, even though its state ($|ND\rangle$ or $[ND]$) belongs to the adopted basis, the probability DP to decay (transition to $|D\rangle$ or $[D]$) is still the same and not unity; only if the nucleus has already decayed, then the *next* state is the same as the *current* state with unity probability. It is thus evident that none of those linear equations could be valid until the nucleus does decay and the reason is because [R-Time](#) does not appear in them. Making [R-Time](#) (*actual* by conception) part of the state converts a non-event (metastable \rightarrow metastable) and (stable \rightarrow stable) into an *actual* transition. Also, realizing that the superpositions depend on whether the nucleus has decayed or not, our possible superpositions in matrix form are:

2-Superpositions (ontic pure states)

$$\begin{bmatrix} |k, ND\rangle \\ |k, D\rangle \end{bmatrix} = \begin{bmatrix} s_1 & s_2 \\ 0 & 1 \end{bmatrix} \begin{bmatrix} |k+1, ND\rangle \\ |k+1, D\rangle \end{bmatrix} ; \quad \begin{bmatrix} |k+1, ND\rangle \\ |k+1, D\rangle \end{bmatrix} = \begin{bmatrix} 1 & -s_2 \\ s_1 & 1 \end{bmatrix} \begin{bmatrix} |k, ND\rangle \\ |k, D\rangle \end{bmatrix} ; \quad s_1 s_1^* = SP ; \quad s_2 s_2^* = DP$$

or (22)

1-Superpositions (ontic convex states)

$$\begin{bmatrix} [k, ND] \\ [k, D] \end{bmatrix} = \begin{bmatrix} SP & DP \\ 0 & 1 \end{bmatrix} \begin{bmatrix} [k+1, ND] \\ [k+1, D] \end{bmatrix} ; \quad \begin{bmatrix} [k+1, ND] \\ [k+1, D] \end{bmatrix} = \begin{bmatrix} 1/SP & -DP/SP \\ 0 & 1 \end{bmatrix} \begin{bmatrix} [k, ND] \\ [k, D] \end{bmatrix}$$

Note both matrices are *not* unitary and that now all bases depend on time, e.g. for the presumed *pure* state $|k, ND\rangle$, the basis is $MB = \{|k+1, ND\rangle, |k+1, D\rangle\}$. The *current* state is not in the *current* MB any longer, so that both types of superposition make sense for a given k . However, if the transition equations are to be valid for all **R-Times**, when using them recursively, the 2-norm for $|k, ND\rangle$ and/or the sum of the coefficients for $[k, ND]$ should be equal to unity for all **R-Times** (as the 2-norm of the solution of **Schrödinger's Equation** does). Let us express the original metastable state $|0, ND\rangle$ after k time intervals:

$$\begin{aligned} |0, ND\rangle &= s_1 |1, ND\rangle + s_2 |1, D\rangle = s_1 \{s_1 |2, ND\rangle + s_2 |2, D\rangle\} + s_2 |2, D\rangle = \\ &= s_1^2 |2, ND\rangle + \{s_1 s_2 + s_2\} |2, D\rangle = s_1^3 |3, ND\rangle + s_2 \{s_1^2 + s_1 + 1\} |3, D\rangle \\ &\quad \vdots \end{aligned} \tag{23}$$

$$|0, ND\rangle = s_1^k |k, ND\rangle + \left\{ s_2 \sum_{j=0}^{k-1} s_1^j \right\} |k, D\rangle \Rightarrow \left| s_2 \sum_{j=0}^{k-1} s_1^j \right|^2 = 1 - |s_1^k|^2 = 1 - SP^k \quad \forall k$$

It can be proven that there is no pair of complex numbers s_1 and s_2 that would verify the condition in **Equation 23** (bottom right) needed for the 2-norm of $|0, ND\rangle$ to always remain unity. In fact, the condition is verified for $k \leq 2$ if $s_1 = i\sqrt{SP}$ and $s_2 s_2^* = DP$ but fails for $k \geq 3$. Therefore, such a putative pure state cannot represent the nuclear decay process and, clearly, the resulting **R-Time** evolution would not be governed by the **Schrödinger's Equation** (in particular, it would lose its *probabilistic* interpretation).

Instead, despite not obeying **Schrödinger's Equation** either, it is easy to prove that the corresponding condition for convex superpositions is automatically verified for all times:

$$[0, ND] = SP^k [k, ND] + \left\{ DP \sum_{j=0}^{k-1} SP^j \right\} [k, D] = SP^k [k, ND] + \{1 - SP^k\} [k, D] \quad \forall k \tag{24}$$

Equation 24 simply says that: (a) the probability to survive k time steps is the product of the identical k probabilities to survive each step, i.e. $\prod_{j=1}^k e^{-j\Delta t/\tau} = e^{-k\Delta t/\tau} = e^{-t/\tau}$; and (b) the probability to decay at time k is the sum of the probabilities to decay in the first step, to survive in one step and decay, to survive in two steps and decay, and so forth up to surviving in $k - 1$ steps

and decaying. Figure 6 depicts the state-transition graph, bases transformations, and initial state expression for the first three time-steps. Notice the differences with the graph for the quincunx.

Failure of Equations 23 and success of Equations 24 clearly say that the state of a metastable radioactive nucleus cannot be quantically *pure* (coherent) but, instead, it behaves as a *convex* state (i.e. with no interaction between its probable states) when it has not decayed, and as a deterministic stable state after it has decayed. This is the direct result of Curie's and Rutherford's research, i.e. of Equations 19. Therefore, the quantic state of a radioactive nucleus -the intrinsically stochastic component of Schrödinger's hellish machine- is *not pure* but convex, and its time evolution is *not* governed by his iconic equation.

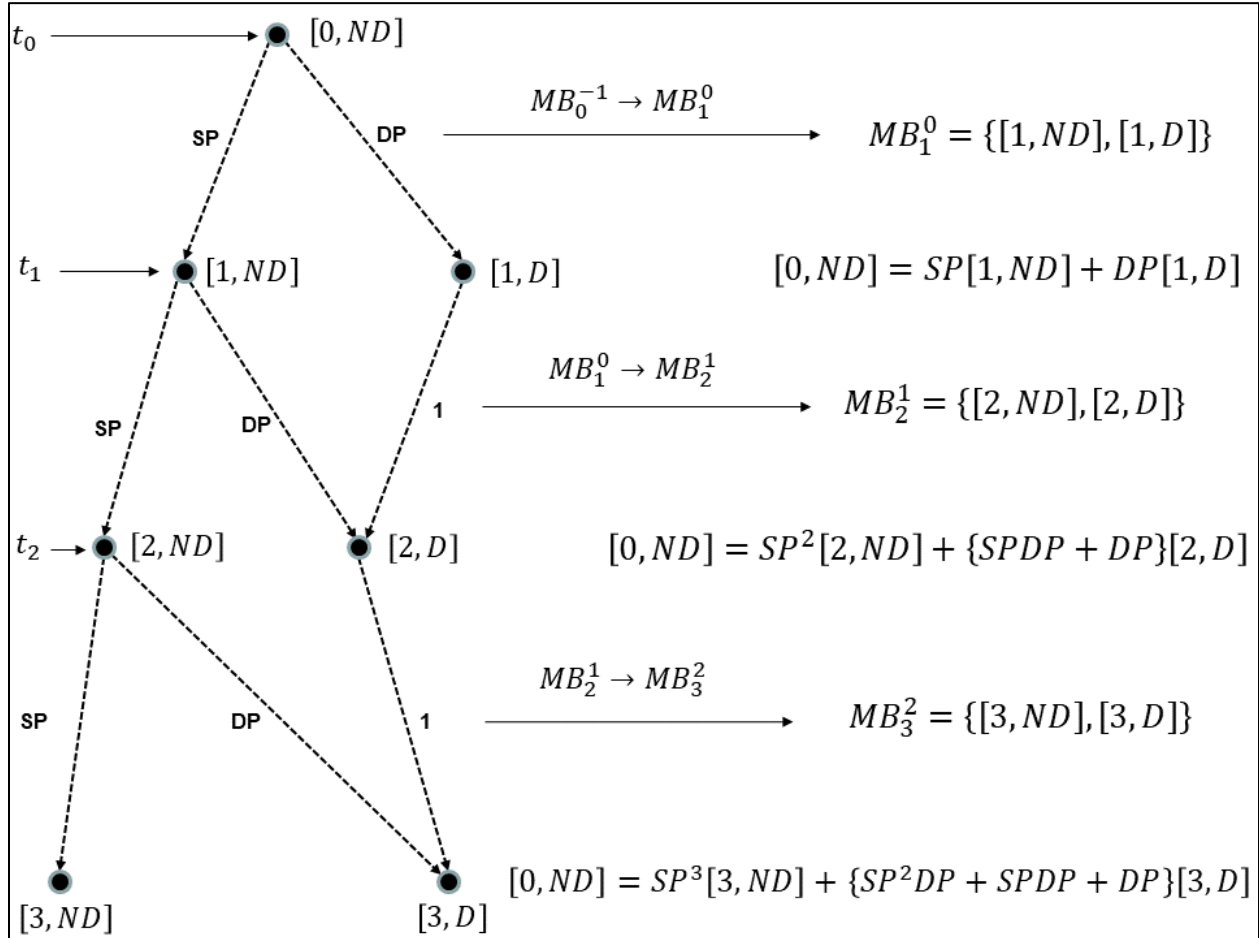

Figure 6: *MB* independent of Milieu. $[k, ND]$ is Convex and $[k, D]$ is Deterministic.

It is a commonplace in the literature to assume that *mixed* states are *epistemic* simply because its probabilities are Kolmogorovian; per QT/TOPI, *epistemic* probabilities are Kolmogorovian, but the reverse is not necessarily true, e.g. the quincunx's *convex states* and *co-states* of a composite quanton – whose probabilities we contended are *ontic*. The same literature uncritically assumes that the nucleus' state is *pure* and that because probabilities are then non-Kolmogorovian, they do not accept an *epistemic* interpretation [51] [89]. The conclusion is correct, but the assumption is not. We have proved that the state of a radioactive nucleus cannot be *pure* though it is as *ontic* as a *pure* state: it simply does not accept the 2-superposition symbolic depiction. These insights have

been ignored for almost a century. Now we can unravel the poorly understood and mystically abused Schrödinger’s “diabolic” device, which plays Russian roulette with his mythical cat.

5.3 Final Analysis

On top of the conceptual revelations of previous sections, it is important to understand that to link the fate of Schrödinger’s cat to the nucleus decay event, the quanton spontaneously emitted by the nucleus must be first detected via a **PDI**, i.e. it must manifest somehow in our **RT**-spacetime. And, to pinpoint how sardonic Schrödinger was and how nonsensical have scientists/philosophers been for the last 90 years, we will simply change the “**room of steel**” with a room of plexiglass.

Under **QT/TOPI**, the direction of the radiated quanton is a random variable so, upon the nucleus’ decay event, the state of the radiated quanton can be decomposed in a continuum of probable trajectories whose integration gives a definite *probability* for the quanton to be absorbed by the detector. Until this absorption occurs, the radiated quanton’s state does evolve according to **Schrödinger’s Equation** – as the photon in the double-slit experiment does until detected (**Figure 5**/bottom). Upon detection, one of the radiated quanton’s probable states becomes actual.

The Geiger counter imagined in **SCHR1** is the *detector* that absorbs the radiated micro-object and amplifies the event via a bottom-up ionization causal process in **RT**’s spacetime, ending up with an electronic pulse powerful enough to activate a standard macro-mechanism that could move the imaginary hammer and break the fictional poison container. This is a “wheels and gears” type of dynamic process, which is causal, highly nonlinear, and irreversible; ergo: **Schrödinger’s Equation** cannot rule it. It is the direct result of having a **PDI** (the Geiger counter) which, together with the diabolic mechanism and the cat’s biological response constitute a causal chain which is assumed flawless. Thus, assuming the Geiger counter misses no emitted quanton and allowing for a brief ailment process for the poor cat if the nucleus decayed, there is a perfect correlation between the decayed/non-decayed state of the nucleus and the dead/alive state of the cat. Notice though that neither the nucleus nor the emitted quanton is part of the dynamic causal chain, which is triggered when the Geiger counter fires.

The detector’s state could also be described in a basis $DB = \{|NF\rangle, |F\rangle\}$ with presumed-pure states corresponding to ‘Not Fired’ and ‘Fired’. For a 100% reliable detector, the counter’s firing event ensures that the nucleus’ *actual* transition $[k, ND] \rightarrow [k + 1, D]$ has occurred. The nucleus’ decay and the emission of its byproduct are *correlated* but it is unwarranted to assume that nucleus and its byproduct were entangled quantons because the latter did not exist until the former decayed. At most, they could be entangled upon the **QEI** accompanying the decay. Likewise, despite the correlation, and being the nucleus state not pure, it is unjustifiable to assume that the mere presence of a detector (a macro-object) close by where the byproduct may appear makes the nucleus, the radiated quanton, and the detector to be quantumly entangled. Entanglement in general exhibits correlation but *not* the reverse though, in any case, such a hypothetical entanglement would be **broken** upon detection leaving a record of their correlation and revealing the actual ‘decayed’ state.

Just as incongruously, we could overly simplify the complex physical state of the cat by assuming it is quantumly pure and, by adopting the arbitrary basis $CB = \{|CA\rangle, |CD\rangle\}$ for ‘Cat Alive’ and ‘Cat Dead’, we could now replace **Equation 21** (left) by:

$$|s\rangle = s_1|ND\rangle|NF\rangle|CA\rangle + s_2|D\rangle|F\rangle|CD\rangle \quad ; \quad s_1s_1^* = SP \quad ; \quad s_2s_2^* = DP \quad (25)$$

Via a *pure* composite state, Equation 25 would expose the *entanglement* (hence correlation) between the nucleus decay and the cat’s misfortune. But despite lacking any foundation for the *pureness* of the nucleus’ state (much less for the detector/amplifier/cat) and thus for considering such entanglement between the nucleus (a micro-object) and the cat (a macro-object) as real, it is clear from previous discussions that such hypothetical entanglement would break down upon the detector clicking. The latter is a **PDI** and, ergo, a nonlinear and irreversible process that delivers an actual detector’s state that triggers a *dynamic causal* chain in **RT**-spacetime culminating in an actual state for the cat – irrespective of whether the machine walls are transparent, whether we are looking through them, or whether Wigner, his friend, or the rest of humanity are aware of the events. Even so, the term ‘cat states’ for *entangled* states was coined and used till today.

And it does not matter a bit whether we have in the “**room of steel**” a living organism with a brain [44] or an inert macro-object: we could simply watch for the container’s broken/unbroken state. To confirm, simply stay looking through the plexiglass walls until the Geiger counter clicks and we see the broken container. And that could happen in the first second of the “one hour” we were supposed to wait before entering the originally opaque room. What other reason did Schrödinger have to choose a “**room of steel**”? And, please, let us not suggest that our looking somehow “collapses the wavefunction” – a wavefunction we proved cannot represent the radioactive nucleus state in any sensible way, let alone the whole system (which inevitably must include a **PDI** at the very start of the *dynamic causal* chain). Or that our frequent peeking delays or accelerates the collapse through the Zeno/anti-Zeno effects. Or that the cat who I see dead in our world is seen alive by a copy of myself in another world or, equivalently, that the cat is immortal because there will always be a world in which s/he survives [90] [61] [62]. At some point we, scientists/philosophers, must come to our senses. A century is a long time, as our astonishing technological progress attests. Obviously, the latter does not go hand in hand with our sensibleness.

6. Conclusions

Reductionism -if it works- does not imply straightforward constructionism, but some philosophers and scientists, infatuated with linearity and **Schrödinger’s Equation**, obstinately expected that all those *sui generis* micro-phenomena had to scale-up to the macroworld without exception. Others, knowing such scale-up was clearly invalid, tried desperately to conceive quantic-like processes to explain the difference. We thus fell in the trap of century-long mostly misguided philosophical discussions on the link between the microcosm and the macroworld.

The ‘weirdness’ of the quantum world is the result of conflating Reality with Actuality and the quanton with its states. The actual is real but not everything real is actual: observation and measurement are anthropic; the Universe is out there with or without our cognitive endeavors. The ontic character of probable states can only be inferred from experimental setups that do not convert them into actual. The real state comprises all its depictions, one for each **MB** in a multitude of **PIs**. Given the ontic state and a **PI**, all bases are valid. Using a basis other than **MB** requires a basis transformation. Because inner product and trace operation are basis-invariant, for a current state and milieu, the transition **PD** is ontic and basis-invariant, so all representations do describe the same Reality. States, properties, and milieu are real; bases and superpositions are abstract tools. Being probable and actual states real, the former can evolve and interact as the latter do. When an actual transition occurs, only one of the probable next states becomes actual. Because a quanton has no size or shape, its milieu may be a network of local **PIs** which are spacelike-separated. Ergo,

the co-extant probable states of a single quanton may undergo different local **PIs** and interact among themselves via **ITIs**. Likewise for probable states of sub-quantons in a composite quanton.

A **PDI** is a sine qua non for what the **QT** literature calls a “measurement”. A **PDI** is nonlinear and irreversible; ergo, it cannot be governed by **Schrödinger’s Equation**. **PDI**s manifest in our spacetime and are the triggers of actuality. A **PTI**, instead, is purely transformational upon which, unless the current state is already actual and belongs to the **MB**, the **PD** is not actualized. All transitions in a **PTI** are probable, the quanton evolving without revealing itself in our spacetime. Previous and current **MBs** are related via a unitary transformation, which can be viewed as a state transformation under a single basis – with the state’s components transforming as the bases do. Ergo, the basis transformation also rules how the components of the previous state morph into the components of the current state and the latter into the components of the next state. Hence, despite the stochasticity of **QT**, such transformation is interpretable as a linear, reversible, deterministic evolution of probable states. This is what **Schrödinger’s Equation** does: it describes the deterministic **R-Time** evolution for the quanton’s energy probability distribution.

The so-called ‘Basis Problem’ is misguided; under **QT/TOPI**, all bases are legitimate regardless of state and milieu. For each milieu, the **MB** is preferred for the same reason that decomposing the gravity force along the rod and its perpendicular direction is preferred for the **pendulum** (it helps the application of Newton’s gravity and motion laws). Of course, the separate problem of determining the **MB** for each **PI** does remain. Bases are not physical entities and, ergo, there cannot exist a dynamic process in **RT**-spacetime that leads to one basis instead of another.

The so-called ‘measurement problem’, as typically articulated, is a pseudo-problem because its premise is false. The states in the superposition represent ontic probable states, not actual states. The expression “the system is in a superposition of states” has no physical meaning; the quanton is in a well-defined actual or probable ontic state which can be symbolically depicted in infinite ways. Superpositions are mere mathematical depictions of an ontic state. If one of the next states becomes actual (after a **PDI**), then of course we experimentally see only one state; otherwise (upon only a **PTI**), all next states are probable and real. There is need to conceive neither a physical nor a metaphysical “collapse” process that would convert many actual states into a single actual state. Under **QT/TOPI**, a more sensible variant of the ‘measurement problem’ can be reformulated in non-anthropic terms as a real problem, viz: when a **PI** is or includes a **PDI**? However, as such, it is not part of **QT** per se (at least not of what we call **QT** today) and will be tackled in future papers.

Against conventional wisdom, the state of a radioactive nucleus is ontic but not pure. Hence, the only innately stochastic part of Schrödinger’s hellish machine is not pure, and its evolution is not governed by his iconic equation. Likewise, the detector -if fired- triggers a “wheels and gears” process in our **RT**-spacetime that is causal, highly nonlinear, and irreversible, so **Schrödinger’s Equation** cannot rule it either. It culminates in an actual state for the cat – irrespective of whether the machine walls are transparent, we are looking through them, or whether Wigner, his friend, or the rest of humanity are aware of the events. And it does not matter a bit whether we have in the “**room of steel**” a living organism with a brain or merely an inert breakable poison container.

Future articles will reveal how many other so-called ‘paradoxes’ are fully explained under **QT/TOPI**, establishing its soundness and potential for nurturing further theoretical and technological advance. In particular, Part IV [1] introduces **QR/TOPI**: a new theory that has grown out of **QT/TOPI** to solve the century-old problem of integrating **RT** with **QT**.

APPENDIX

Dissection of EPRB with the Density Operator Formalism

Let us apply the density operator formalism and conceptually dissect the **EPRB** experiment in the light of **QT/TOPI**. The composite state $|s\rangle$ is *pure*, so its density operator $\rho = |s\rangle\langle s|$ is simply its own projector, i.e. there is a basis in which the convex superposition has only one term with unity coefficient. Equivalently, for such basis, the density matrix $\underline{\rho}$ is diagonal with one element equal to one and all others equal to zero. Using **Equations 11** (top line), we calculate the density matrix $\underline{\rho}$ and its diagonal version $\underline{\rho}_D$ for the composite quanton:

$$\underline{\rho} = \begin{bmatrix} \frac{1}{2}\sin^2\left(\frac{\theta}{2}\right) & \frac{1}{2}\sin\left(\frac{\theta}{2}\right)\cos\left(\frac{\theta}{2}\right) & -\frac{1}{2}\sin\left(\frac{\theta}{2}\right)\cos\left(\frac{\theta}{2}\right) & -\frac{1}{2}\sin^2\left(\frac{\theta}{2}\right) \\ \frac{1}{2}\sin\left(\frac{\theta}{2}\right)\cos\left(\frac{\theta}{2}\right) & \frac{1}{2}\cos^2\left(\frac{\theta}{2}\right) & -\frac{1}{2}\cos^2\left(\frac{\theta}{2}\right) & -\frac{1}{2}\sin\left(\frac{\theta}{2}\right)\cos\left(\frac{\theta}{2}\right) \\ -\frac{1}{2}\sin\left(\frac{\theta}{2}\right)\cos\left(\frac{\theta}{2}\right) & -\frac{1}{2}\cos^2\left(\frac{\theta}{2}\right) & \frac{1}{2}\cos^2\left(\frac{\theta}{2}\right) & \frac{1}{2}\sin\left(\frac{\theta}{2}\right)\cos\left(\frac{\theta}{2}\right) \\ -\frac{1}{2}\sin^2\left(\frac{\theta}{2}\right) & -\frac{1}{2}\sin\left(\frac{\theta}{2}\right)\cos\left(\frac{\theta}{2}\right) & \frac{1}{2}\sin\left(\frac{\theta}{2}\right)\cos\left(\frac{\theta}{2}\right) & \frac{1}{2}\sin^2\left(\frac{\theta}{2}\right) \end{bmatrix} \Rightarrow \underline{\rho}_D = \begin{bmatrix} 1 & 0 & 0 & 0 \\ 0 & 0 & 0 & 0 \\ 0 & 0 & 0 & 0 \\ 0 & 0 & 0 & 0 \end{bmatrix}$$

From **Equations 12**, the matrices $\underline{\rho}_A$ and $\underline{\rho}_B$ for the qubits' co-states and their squares are:

$$\underline{\rho}_A = \begin{bmatrix} 1/2 & -\sin\left(\frac{\theta}{2}\right)\cos\left(\frac{\theta}{2}\right) \\ -\sin\left(\frac{\theta}{2}\right)\cos\left(\frac{\theta}{2}\right) & 1/2 \end{bmatrix} ; \quad \underline{\rho}_B = \begin{bmatrix} 1/2 & \sin\left(\frac{\theta}{2}\right)\cos\left(\frac{\theta}{2}\right) \\ \sin\left(\frac{\theta}{2}\right)\cos\left(\frac{\theta}{2}\right) & 1/2 \end{bmatrix}$$

↓

(A1)

$$\underline{\rho}_A^2 = \begin{bmatrix} 1/4 + \sin^2\left(\frac{\theta}{2}\right)\cos^2\left(\frac{\theta}{2}\right) & -\sin\left(\frac{\theta}{2}\right)\cos\left(\frac{\theta}{2}\right) \\ -\sin\left(\frac{\theta}{2}\right)\cos\left(\frac{\theta}{2}\right) & 1/4 + \sin^2\left(\frac{\theta}{2}\right)\cos^2\left(\frac{\theta}{2}\right) \end{bmatrix} ; \quad \underline{\rho}_B^2 = \begin{bmatrix} 1/4 + \sin^2\left(\frac{\theta}{2}\right)\cos^2\left(\frac{\theta}{2}\right) & \sin\left(\frac{\theta}{2}\right)\cos\left(\frac{\theta}{2}\right) \\ \sin\left(\frac{\theta}{2}\right)\cos\left(\frac{\theta}{2}\right) & 1/4 + \sin^2\left(\frac{\theta}{2}\right)\cos^2\left(\frac{\theta}{2}\right) \end{bmatrix}$$

We see that $tr(\underline{\rho}) = tr(\underline{\rho}_A) = tr(\underline{\rho}_B) = 1$ as it should be for density matrices. However, in general, $\underline{\rho}_A^2 \neq \underline{\rho}_A$, $tr(\underline{\rho}_A^2) < 1$, $\underline{\rho}_B^2 \neq \underline{\rho}_B$, and $tr(\underline{\rho}_B^2) < 1$, so neither quanton *A* nor quanton *B* are in ontic pure states but in ontic entangled states, i.e. *co-states*. Let us diagonalize $\underline{\rho}_A$ and $\underline{\rho}_B$:

$$\underline{\rho}_{AD} = \begin{bmatrix} 1/2 + \sin\left(\frac{\theta}{2}\right)\cos\left(\frac{\theta}{2}\right) & 0 \\ 0 & 1/2 - \sin\left(\frac{\theta}{2}\right)\cos\left(\frac{\theta}{2}\right) \end{bmatrix} ; \quad \underline{\rho}_{BD} = \begin{bmatrix} 1/2 - \sin\left(\frac{\theta}{2}\right)\cos\left(\frac{\theta}{2}\right) & 0 \\ 0 & 1/2 + \sin\left(\frac{\theta}{2}\right)\cos\left(\frac{\theta}{2}\right) \end{bmatrix} \quad (A2)$$

From the diagonalized matrices, we see that, in general, no unity eigenvalue exists, confirming again that co-states are entangled. Inspecting the common trace of the squared matrices, based on the global milieu (θ), the sub-quantons display different degrees of correlation:

$$tr\{\underline{\rho}_A^2\} = tr\{\underline{\rho}_B^2\} = 1/2 + 2\sin^2\left(\frac{\theta}{2}\right)\cos^2\left(\frac{\theta}{2}\right) = \begin{cases} < 1 \text{ for } \theta \neq \frac{\pi}{2}; \frac{3\pi}{2}; \frac{5\pi}{2}; \frac{7\pi}{2} \dots \text{ (Correlated)} \\ = 1 \text{ for } \theta = \frac{\pi}{2}; \frac{3\pi}{2}; \frac{5\pi}{2}; \frac{7\pi}{2} \dots \text{ (Uncorrelated)} \end{cases} \quad (A3)$$

$\theta = 0$ or $\theta = \pi$ (A and B in entangled states with maximal correlation)

$$\underline{\rho}_A = \underline{\rho}_B = \begin{bmatrix} 1/2 & 0 \\ 0 & 1/2 \end{bmatrix} ; \underline{\rho}_A^2 = \underline{\rho}_B^2 = \begin{bmatrix} 1/4 & 0 \\ 0 & 1/4 \end{bmatrix} ; \text{tr} \{ \underline{\rho}_A^2 \} = \text{tr} \{ \underline{\rho}_B^2 \} = 1/2 < 1 \quad (A4)$$

For both global milieus, the spins out of the two magnets keep the same relation to their local magnetic fields because the **teleported spin** is always anti-collinear to the spin randomly assumed by the quanton that first undergoes a **GI** (Figure 3). The local density matrices are diagonal and identical, with the trace of their square smaller than unity (1/2) – confirming they are **not isolated** but entangled *co-states* with maximal correlation.

For $\theta = 0$, the global state assumes the form $|s\rangle = \sqrt{2}/2 |s_{A1}\rangle|s_{B2}\rangle - \sqrt{2}/2 |s_{A2}\rangle|s_{B1}\rangle$, which is typically referred to in the literature as the *singlet* state (Figure 3). Again, per **TOPI**, the ontic composite state is one and the same; it is the global milieu that has specialized the mathematical description. The Mean of the global property $\mathcal{P}_A \mathcal{P}_B$ is equal to -1 with nil **SD** (Equations 11/last line), viz it behaves *deterministically* despite the full randomness local ones (\mathcal{P}_A and \mathcal{P}_B) exhibit. There is a maximal negative correlation among physical properties: $-\cos(0) = -1$.

For $\theta = 180^\circ$, the composite state becomes $|s\rangle = \sqrt{2}/2 |s_{A1}\rangle|s_{B1}\rangle - \sqrt{2}/2 |s_{A2}\rangle|s_{B2}\rangle$. The Mean is unity with nil **SD** and, again, the global property behaves deterministically despite the local ones behaving with full randomness. The two physical properties are maximally correlated: $-\cos(\pi) = 1$. This agrees with Figure 3 after rotating one of the magnets by 180° .

$\theta \neq 0; \frac{\pi}{2}; \pi; \frac{3\pi}{2}; 2\pi; \frac{5\pi}{2}; 3\pi; \frac{7\pi}{2} \dots$ (A and B in entangled states with partial correlation)

For $\theta: 0 \rightarrow \pi/2$, the correlation goes from $(-1) \rightarrow 0$, while the **SD** increases from $0 \rightarrow 1$. For $\theta: \pi/2 \rightarrow \pi$, the correlation goes from $0 \rightarrow 1$, while the **SD** decreases towards zero again. For $\theta: \pi \rightarrow 3\pi/2$, the correlation goes from $1 \rightarrow 0$, while the **SD** increases from $0 \rightarrow 1$. For $\theta: 3\pi/2 \rightarrow 2\pi$, the correlation varies from $0 \rightarrow -1$, while the **SD** decreases from $1 \rightarrow 0$. The local density matrices are not diagonal, and the trace of the squared density matrices is always smaller than unity. The sub-quantons' eigenstates are correlated in different degrees from maximally anti-correlated ($\theta = 0$) to maximally correlated ($\theta = \pi$). Let us instantiate the case $\theta = 50^\circ$ using Equations 11/top:

$$|s\rangle = 0.2988|s_{A1}\rangle|s_{B1}\rangle + 0.641|s_{A1}\rangle|s_{B2}\rangle - 0.641|s_{A2}\rangle|s_{B1}\rangle - 0.2988|s_{A2}\rangle|s_{B2}\rangle$$

$$\underline{\rho}_A = \begin{bmatrix} 1/2 & -0.383 \\ -0.383 & 1/2 \end{bmatrix} ; \underline{\rho}_{AD} = \begin{bmatrix} 0.883 & 0 \\ 0 & 0.117 \end{bmatrix} ; \underline{\rho}_B = \begin{bmatrix} 1/2 & 0.383 \\ 0.383 & 1/2 \end{bmatrix} ; \underline{\rho}_{BD} = \begin{bmatrix} 0.117 & 0 \\ 0 & 0.883 \end{bmatrix}$$

$$\text{Corr} = \{ \langle \mathcal{P}_A \mathcal{P}_B \rangle - \langle \mathcal{P}_A \rangle \langle \mathcal{P}_B \rangle \} / \Delta \mathcal{P}_A \Delta \mathcal{P}_B = -\cos(50^\circ) = -0.6428$$

$\theta = \pi/2, 3\pi/2, \dots$ (A and B in entangled states but uncorrelated)

$$\theta = \pi/2 \Rightarrow \underline{\rho}_A = \underline{\rho}_A^2 = \begin{bmatrix} 1/2 & -1/2 \\ -1/2 & 1/2 \end{bmatrix} ; \underline{\rho}_B = \underline{\rho}_B^2 = \begin{bmatrix} 1/2 & 1/2 \\ 1/2 & 1/2 \end{bmatrix} ; \text{tr} \{ \underline{\rho}_A^2 \} = \text{tr} \{ \underline{\rho}_B^2 \} = 1$$

$$\underline{\rho}_A \xrightarrow{\text{Diagonalizing}} \underline{\rho}_{AD} = \begin{bmatrix} 1 & 0 \\ 0 & 0 \end{bmatrix} ; \underline{\rho}_B \xrightarrow{\text{Diagonalizing}} \underline{\rho}_{BD} = \begin{bmatrix} 0 & 0 \\ 0 & 1 \end{bmatrix} \quad (A5)$$

$$\text{Equation 11/top} \Rightarrow |s\rangle = \left\{ \frac{\sqrt{2}}{2} |s_{A1}\rangle - \frac{\sqrt{2}}{2} |s_{A2}\rangle \right\} \left\{ \frac{\sqrt{2}}{2} |s_{B1}\rangle + \frac{\sqrt{2}}{2} |s_{B2}\rangle \right\} \quad (\text{Product State})$$

$$\theta = 3\pi/2 \Rightarrow \underline{\rho}_A = \underline{\rho}_A^2 = \begin{bmatrix} 1/2 & 1/2 \\ 1/2 & 1/2 \end{bmatrix} ; \underline{\rho}_B = \underline{\rho}_B^2 = \begin{bmatrix} 1/2 & -1/2 \\ -1/2 & 1/2 \end{bmatrix} ; \text{tr} \{ \underline{\rho}_A^2 \} = \text{tr} \{ \underline{\rho}_B^2 \} = 1$$

$$\underline{\rho}_A \xrightarrow{\text{Diagonalizing}} \begin{bmatrix} 0 & 0 \\ 0 & 1 \end{bmatrix} ; \underline{\rho}_B \xrightarrow{\text{Diagonalizing}} \begin{bmatrix} 1 & 0 \\ 0 & 0 \end{bmatrix} \quad (\text{A6})$$

$$\text{Equations 11/top} \Rightarrow |s\rangle = \left\{ \frac{\sqrt{2}}{2} |s_{A1}\rangle + \frac{\sqrt{2}}{2} |s_{A2}\rangle \right\} \left\{ \frac{\sqrt{2}}{2} |s_{B1}\rangle - \frac{\sqrt{2}}{2} |s_{B2}\rangle \right\} \quad (\text{Product State})$$

For $\theta = 90^\circ$ and $\theta = 270^\circ$ the global Mean is nil, and the global **SD** is unity, which means that the global property $\mathcal{P}_A \mathcal{P}_B$ alternates between +1 and -1 with equal probability. Local and global properties are all perfectly random (50/50) and, apparently, they are fully decoupled. In fact, the global state can be expressed as a product of pure local states corresponding to 90° and 270° relative to their local magnets (**Equations A5** and **A6/bottom**). As explained before, this lack of correlation does not imply a lack of entanglement: because the teleported spin is always anti-collinear to the spin randomly assumed by the quanton that first undergoes a **GI**, when the second qubit (now isolated) experiences a **GI** with a global milieu of $\theta = \pi/2$ ($3\pi/2$), the second magnet is oriented $3\pi/2$ ($\pi/2$) with respect to the second qubit and, hence, the Mean for all local and global properties are zero. The qubits' behaviors are uncorrelated not because they are isolated but because they are entangled while interacting with a unique global milieu. The composite state can be expressed as a product of two *pure* states as confirmed by their diagonalized density matrices whose diagonal has one unity eigenvalue and the other is zero. However, they do *not* represent ontic pure states for the qubits because those 2-superpositions are only valid for $\theta = \pi/2$ and $\theta = 3\pi/2$ but fail for any other global milieu. Both qubits are in ontic *co-states* (entangled) and remain as such until one of the qubits undergoes a **GI**.

Acknowledgments

I am indebted for their insightful comments to Riccardo Fortunati (New Zealand), Nicholas Alba (USA), Liana Amidžić (Bosnia and Herzegovina), and Melvin Holmes (UK).

References

- [1] F. Alba-Juez, "The Ontic Probability Interpretation of Quantum Theory - Part IV - QR/TOPI: How to Complete Special Relativity and Merge it with Quantum Theory," 2024. [Online]. Available: TBD.
- [2] A. Einstein, B. Podolsky and N. Rosen, "Can Quantum-Mechanical Description of Physical Reality be Considered Complete?," *Physical Review*, vol. 47, pp. 777-780, 1935.
- [3] F. Alba-Juez, *Elements of REALITY - 1925-1935: The Onset of an Unfinished Philosophical Struggle*, Saint George, Utah: Felix Alba-Juez, Publisher, 2019.
- [4] F. Alba-Juez, "The Ontic Probability Interpretation of Quantum Theory - Part I - The Meaning of Einstein's Incompleteness Claim," 5 February 2020. [Online]. Available: <https://philpapers.org/rec/ALBTOP-2>.
- [5] F. Alba-Juez, "The Ontic Probability Interpretation of Quantum Theory - Part II - Einstein's Incompleteness/Nonlocality Dilemma," 5 February 2020. [Online]. Available: <https://philpapers.org/rec/ALBTOP>.
- [6] E. Schrödinger, "The Present Status of Quantum Mechanics," *Die Naturwissenschaften*, vol. 23, no. 48, 49, 50, pp. 807-812 / 823-828 / 844-849, 1935.
- [7] G. Brassard and A. A. Methot, "Can quantum-mechanical description of physical reality be considered incomplete?," 30 December 2006. [Online]. Available: <http://arxiv.org/abs/quant-ph/0701001v1>.
- [8] E. Schrödinger, "Discussion of probability relations between separated systems," *Proceedings of the Cambridge Philosophical Society*, vol. 31, pp. 555-563, 1935.
- [9] E. Schrödinger, "Probability relations between separated systems," *Mathematical Proceedings of the Cambridge Philosophical Society*, vol. 32, no. 03, pp. 446-452, 1936.
- [10] E. Schrödinger, "Are there quantum jumps?," *The British Journal for the Philosophy of Science*, vol. III, no. 11, pp. 233-242, 1952.
- [11] A. Suarez, "Decision at the beam-splitter, or decision at detection, that is the question," 15 April 2013. [Online]. Available: arXiv:1204.5848v2.
- [12] N. Gisin, "Collapse. What else?," 25 April 2017. [Online]. Available: <http://arxiv.org/abs/1701.08300v2>.
- [13] B. Drossel, "Ten reasons why a thermalized system cannot be described by a many-particle wave function," 31 January 2017. [Online]. Available: <https://arxiv.org/abs/1509.07275>.
- [14] B. Drossel and G. Ellis, "Contextual Wavefunction Collapse: An integrated theory of quantum measurement," 24 November 2018. [Online]. Available: arXiv:1807.08171v2.
- [15] F. Alba-Juez, *Relativity free of Folklore #2 (The Perception of Time... and its Measurement)*, vol. 2, Salt Lake City, USA: Felix Alba-Juez, Publisher, 2011.
- [16] F. Alba-Juez, *Relativity free of Folklore #3 (The Perception of Space... and its Measurement)*, vol. 3, Salt Lake City, USA: Felix Alba-Juez. Publisher, 2011.
- [17] F. Alba-Juez, *Records of the Future - Classical Entropy, Memory, and the 'Arrow of Time'*, Salt Lake City: Felix Alba-Juez, Publisher, 2013.

- [18] F. Alba-Juez, *Aiming at REALITY - Statistical Entropy, Disorder, and the Quantum*, Salt Lake City: Felix Alba-Juez, Publisher, 2017.
- [19] F. Alba-Juez, *Nighing REALITY: Quantum Fusion after 25 Years of Confusion*, Saint George, Utah, USA: Felix Alba-Juez, Publisher, 2018.
- [20] N. Gisin, "Time Really Passes, Science Can't Deny That," 30 January 2016. [Online]. Available: <http://arxiv.org/abs/1602.01497v1>.
- [21] A. Grünbaum, *Philosophical Problems of Space and Time*, New York: Alfred A. Knopf, Inc., 1963.
- [22] A. Grünbaum, "The Nature of Time," *Frontiers of Science and Philosophy*, 1962.
- [23] F. Alba-Juez, "Quantum Physics free of Folklore #1 - Records of the Future - Classical Entropy, Memory, and the 'Arrow of Time'," 2013. [Online]. Available: <http://a.co/am8MWzr>.
- [24] A. d'Abro, *The Rise of the New Physics - Its Mathematical and Physical Theories. Vol. II*, New York: Dover Publications, 1951.
- [25] J. S. Bell, "On the Einstein Podolsky Rosen Paradox," *Physics*, vol. 1, pp. 195-200, 1964.
- [26] S. Kochen and S. E.P., "The Problem of Hidden Variables in quantum mechanics," *Journal of Mathematics and Mechanics*, vol. 17, no. 1, pp. 59-87, 1967.
- [27] J. S. Bell, "On the problem of hidden variables in quantum mechanics," vol. 38, pp. 447-452, 1966.
- [28] K. R. Popper, "Quantum Mechanics without the Observer," [Online]. Available: <http://citeseerx.ist.psu.edu/viewdoc/download?doi=10.1.1.473.23&rep=rep1&type=pdf>. [Accessed 2 February 2016].
- [29] K. R. Popper, *Quantum Theory and the Schism in Physics*, London: Routledge, 1982.
- [30] K. R. Popper, "The Propensity Interpretation of Probability," *The British Journal for the Philosophy of Science*, vol. 10, no. 37, pp. 25-42, 1959.
- [31] N. Gisin, "Real Numbers are the Hidden Variables of Classical Mechanics," 10 September 2019. [Online]. Available: <http://arxiv.org/abs/1909.04514v1>.
- [32] N. Gisin, "Classical and intuitionistic mathematical languages shape our understanding of time in physics," 4 February 2020. [Online]. Available: <http://arxiv.org/abs/2002.01653v1>.
- [33] N. Gisin, "Indeterminism in Physics, Classical Chaos and Bohmian Mechanics: Are Real Numbers Really Real?," 23 October 2019. [Online]. Available: <https://doi.org/10.1007/s10670-019-00165-8>.
- [34] R. P. Feynman, *QED - the strange theory of light and matter*, Princeton, New Jersey, USA.: Princeton University Press, 1985.
- [35] A. Zeilinger, "General properties of lossless beam splitters in interferometry," *Am. J. Phys.*, vol. 49, no. 9, 1981.
- [36] H. Reichenbach, *Philosophic Foundations of Quantum Mechanics*, Mineola, New York: Dover Publications, Inc., 1944.
- [37] A. Zeilinger, *Dance of the Photons - From Einstein to Quantum Teleportation*, New York: Farrar, Strauss and Giroux, 2010.

- [38] K. e. a. Lee, "Entangling macroscopic diamonds at room temperature," *Science*, vol. 334, no. 6060, pp. 1253-1256, 2011.
- [39] C. Abellán, A. Acín and A. e. a. Alarcón, "Challenging local realism with human choices," *Nature*, vol. 557, pp. 212-216, 2018.
- [40] N. Gisin, "Can relativity be considered complete ? - From Newtonian nonlocality to quantum nonlocality and beyond," 20 December 2005. [Online]. Available: arXiv:quant-ph/0512168v1.
- [41] N. Gisin, "On the Impossibility of Covariant Nonlocal "hidden" variables in Quantum Physics," 6 February 2010. [Online]. Available: arXiv:1002.1390v1.
- [42] J. S. Bell, "Beables for quantum field theory," in *Quantum Implications - Essays in Honour of David Bohm*, London and New York, Routledge & Kegan Paul, 1987, pp. 227-234.
- [43] A. E. Allahverdyan, R. Balian and T. M. Nieuwenhuizen, "Understanding quantum measurement from the solution of dynamical models," 1 February 2013. [Online]. Available: arXiv:1107.2138v4.
- [44] G. F. Ellis, "On the limits of quantum theory: Contextuality and quantum-classical cut," 8 May 2012. [Online]. Available: <http://arxiv.org/abs/1108.5261v4>.
- [45] C. Anastopoulos, "Classical Vs Quantum Probability in Sequential Measurements," 4 September 2006. [Online]. Available: <http://arxiv.org/abs/quant-ph/0509019v2>.
- [46] S. Loepp and W. K. Wothers, *Protecting Information - From Classical Error Correction to Quantum Cryptography*, New York: Cambridge University Press, 2006.
- [47] IBM Cloud, "The World First Quantum Computing Platform delivered via the IBM Cloud," 4 May 2016. [Online]. Available: <http://www.research.ibm.com/quantum/>.
- [48] T. Guerreiro and e. al, "Single-photon space-Like antibunching," 8 April 2012. [Online]. Available: arXiv:1204.1712v1 [quant-ph] 8 Apr 2012.
- [49] A. Jabs, "Quantum mechanics in terms of realism," *Physics Essays*, vol. 9, no. 354, pp. 36-95, 1996.
- [50] C. de Ronde, "Quantum Superpositions do Exist!," 2015. [Online]. Available: <http://philsci-archive.pitt.edu/11330/>.
- [51] C. de Ronde, "Quantum Superpositions and the Representation of Physical Reality Beyond Measurement Outcomes and Mathematical Structures," *Foundations of Science*, vol. 23, p. 621-648, 2018.
- [52] C. de Ronde, "Measuring Quantum Superpositions (Or, "It is only the theory which decides what can be observed.")," 2 July 2020. [Online]. Available: <http://arxiv.org/abs/2007.01146v1>.
- [53] C. de Ronde, "The Logos Categorical Approach to Quantum Mechanics: I. Kochen-Specker Contextuality and Global Intensive Valuations," 1 January 2018. [Online]. Available: <http://arXiv:1801.00446v1>.
- [54] C. de Ronde, "Representing Quantum Superpositions: Powers, Potentia, and Potential Effectuations," 27 December 2013. [Online]. Available: <http://arxiv.org/abs/1312.7322v1>.
- [55] C. de Ronde, "Defense of of the Paraconsistent Approach to Quantum Superpositions," 17 February 2015. [Online]. Available: <http://arxiv.org/abs/1404.5186v2>.

- [56] C. de Ronde, "'Probabilistic Knowledge as Objective Knowledge in Quantum Mechanics: Potential Immanent Powers instead of Actual Properties," in *Probing the Meaning of Quantum Mechanics: Superpositions, Semantics, Dynamics and Identity*, , Singapore, World Scientific; D. Aerts, C. de Ronde, H. Freytes and R. Giuntini (Eds.), 2016, pp. 141-178 .
- [57] C. Rovelli, "Quantum Weirdness isn't weird - if we accept objects don't exist," *NewScientist*, 10 March 2021.
- [58] C. Rovelli, "Relational Quantum Mechanics," February 24 1997. [Online]. Available: <http://arxiv.org/abs/quant-ph/9609002v2>.
- [59] S. Saunders, J. Barrett, A. Kent and D. Wallace, *Many Worlds? Everett, Quantum Theory, & Reality*, Oxford: Oxford University Press, 2012.
- [60] M. Tegmark, "The Interpretation of Quantum Mechanics: Many Worlds or Many Words?," 15 September 1997. [Online]. Available: [arXiv:quant-ph/9709032v1](https://arxiv.org/abs/quant-ph/9709032v1).
- [61] D. Deutsch, *The Fabric of Reality - The Science of Parallel Universes and Its Implications*, New York: Penguin Books, 1997.
- [62] S. Carroll, *Something deeply Hidden - Quantum Worlds and the Emergence of Spacetime*, Dutton, 2019.
- [63] D. Z. Albert and B. Loewer, "Interpreting the Many Worlds Interpretation," *Synthese*, vol. 77, pp. 195-213, 1988.
- [64] R. B. Griffiths, *Consistent quantum theory*, Cambridge: Cambridge University, 2002.
- [65] J. Hartle, "Living in a Quantum Superposition," 2015. [Online]. Available: [qqantph/arXiv:1511.01550](https://arxiv.org/abs/quant-ph/1511.01550).
- [66] R. Omnès, *Quantum Philosophy - Understanding and Interpreting Contemporary Science*, Princeton and Oxford: Princeton University Press, 2002.
- [67] R. Omnès, *Understanding Quantum Mechanics*, Princeton, New Jersey: Princeton University Press, 1999.
- [68] C. de Ronde, "The (Quantum) Measurement Problem in Classical Mechanics," 1 January 2020. [Online]. Available: [arXiv:2001.00241v1 \[quant-ph\]](https://arxiv.org/abs/2001.00241v1).
- [69] C. de Ronde, "The Contextual and Modal Character of Quantum Mechanics, PhD Dissertation," 2011. [Online]. Available: <https://dspace.library.uu.nl/handle/1874/212787>.
- [70] C. de Ronde, "The Paraconsistent Logic of Quantum Superpositions," 13 June 2013. [Online]. Available: [http://de.arxiv.org/abs/1306.3121v1](https://arxiv.org/abs/1306.3121v1).
- [71] D. Bohm, *Quantum Theory*, Englewood Cliffs, NJ: Prentice-Hall, 1951.
- [72] D. Dieks, "Information and the Quantum World," *Entropy*, vol. 18, no. 26, 2016.
- [73] D. Dieks, "Niels Bohr and the Formalism of Quantum Mechanics," January 2016. [Online]. Available: <https://www.researchgate.net/publication/306228312>.
- [74] D. Dieks, "Quantum Mechanics, Chance and Modality," *Philosophica*, vol. 83, pp. 117-137, 2010.
- [75] R. E. Kastner, "'Einselection' of Pointer Observables: The New H-Theorem?," 16 June 2014. [Online]. Available: <https://arxiv.org/abs/1406.4126>.
- [76] J. Briggs and J. M. Rost, "On the Derivation of the Time-Dependent Equation of Schrödinger," *Foundations of Physics*, vol. 31, no. 4, pp. 693-712, 2001.

- [77] P. M. Dirac, *The Principles of Quantum Mechanics*, Oxford, 1930.
- [78] G. Ghirardi, R. A. and W. T., "Unified Dynamic for Microscopic and Macroscopic Systems," *Physical Review D*, vol. 34, pp. 470-491, 1986.
- [79] N. Gisin, "Stochastic Quantum Dynamics and Relativity," *Helvetica Physica Acta*, vol. 62, pp. 363-371, 1989.
- [80] N. Gisin, "The Free Will Theorem, Stochastic Quantum Dynamics and True Becoming in Relativistic Quantum Physics," 6 February 2010. [Online]. Available: arXiv:1002.1392v1.
- [81] A. Bassi and G. Ghirardi, "Dynamical Reduction Models," *Physics Reports*, vol. 379, pp. 257-426, 2003.
- [82] G. R. Ghirardi GC. and P. P., "Relativistic Dynamical Reduction Models: General Framework and Examples," *Foundations of Physics 1990*, vol. 20, pp. 1271-1316, 1990.
- [83] G. Ghirardi, "Entanglement, Nonlocality, Superluminal Signaling and Cloning," 17 May 2013. [Online]. Available: arXiv:1305.2305v2.
- [84] C. de Ronde, "Representational Realism, Closed Theories and the Quantum to Classical Limit," 17 February 2016. [Online]. Available: <http://arxiv.org/abs/1602.05405v1>.
- [85] G. Ellis, "The arrow of time and the nature of spacetime," 1 March 2013. [Online]. Available: arXiv:1302.7291v2 [gr-qc].
- [86] G. F. R. Ellis, "Top-down causation and emergence: some comments on mechanisms," *Interface Focus*, vol. 2, pp. 126-140, 2012.
- [87] G. Ellis, "The arrow of time, the nature of spacetime, and quantum measurement," 7 October 2011. [Online]. Available: http://www.math.uct.ac.za/sites/default/files/image_tool/images/32/Staff/Emeritus_Professors/Prof_George_Ellis/Overview/Quantum_arrowoftime_gfre.pdf.
- [88] M. Bunge, *Controversias en Fisica*, Madrid, Spain: Editorial Technos, S.A., 1983.
- [89] G. Buonocore, "Realism and AntiRealism in Physical and Biological Sciences. Two Cases: Quantum Mechanics and Evolutionary Biology," UNIVERSITÀ DEGLI STUDI DI PADOVA - Munich Center for Mathematical Philosophy, Munich, 2018.
- [90] M. Tegmark, *Our Mathematical Universe - My Quest for the Ultimate Nature of Reality*, New York: Alfred A. Knopf, 2014.
- [91] L. Castellani, "All quantum mixtures are proper," 11 January 2022. [Online]. Available: arXiv:2201.04143v1 [quant-ph].
- [92] D. Deutsch, "Quantum Theory, the Church-Turing Principle and the Universal Quantum Computer," *Proc. Roy. Soc. Lond.*, vol. A 400, pp. 97-117, 1985.