

LOGIC

A Modern Guide

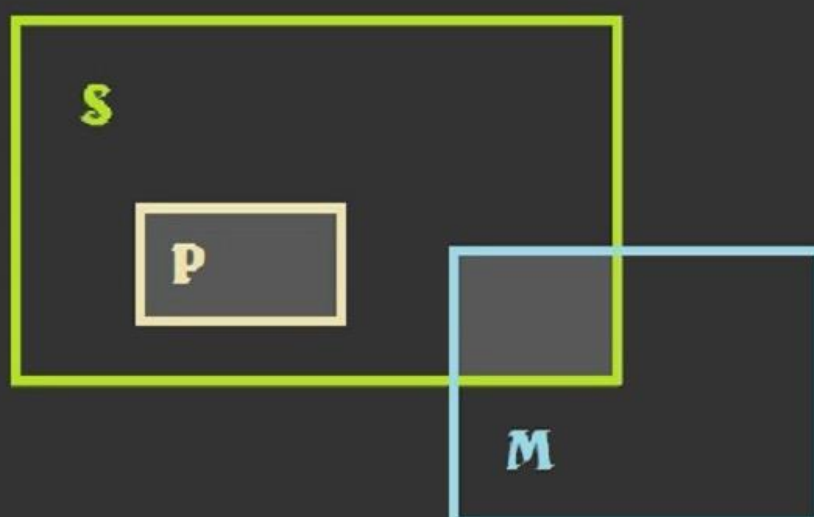

Colin Beckley

LOGIC

A Modern Guide

Copyright © Colin Beckley 2016
The moral right of the author has been asserted,
No part of this publication may be reproduced
in any form without permission, except for
the quotation of brief passages in criticism
and discussion.

Published by Think Logically Books

First published in April 2016

ISBN 9780993193316

Acknowledgements

I wish to thank Lionel Cox who gave such encouragement and enthusiasm as the structure of this short work was prepared. Thanks also once again to the redoubtable Trevor Hussey for his critical philosophical eye which sought out and exposed my many mistakes and oversights. Ian Farmer must also be thanked for his corrections to the grammar in the text and the same applies to John White who also added some valuable novel perspectives. All of the above kindly contributed their time without seeking reward or favour. It is in these circumstances that one perceives and appreciates the good side of human nature.

Contents

Introduction

Traditional Logic and the Categorical Syllogism

Beyond Euler

Modern Logic: Most and Some

Testing Syllogisms with Diagrams

Valid Syllogisms of Traditional Logic

Valid Syllogisms of Modern Logic

Sorites

Conditionals

How to spot invalid arguments

Exercises and Answers

Introduction

Most people, if one were to ask, would say that they are themselves logical thinkers and may even express doubts about the logical abilities of others. And yet if they were probed deeper and asked to explain what a ‘categorical syllogism’ or a ‘universal affirmative proposition’ is, it is unlikely that they could give a satisfactory answer. Some others may declare they see no need to understand the principles of logical thinking and that they are quite content with their own mental abilities. Such a sentiment may however be a little short sighted. Once one has comprehended the methods of logic one is in a better position to evaluate its value and it is highly unlikely that anyone in such a position will discard the methodology.

Learning the methods of logic is not like starting from scratch with an unfamiliar subject, for logical thinking resides in all people with mental faculties that are not seriously impaired. To some it comes easily to others more application is required but still is easily achievable. No one has, however, a perfectly logical mind and anyone who believes that is seriously deluded. One should not be concerned if one makes mistakes for everyone makes logical mistakes but one can reduce these and improve. This book is written for those who wish to learn some basic principles of formal logic but more importantly learn some easy methods to unpick arguments and assess their value for truth and validity.

The first section explains the ideas behind traditional logic which was formed well over two thousand years ago by the ancient Greeks. Terms such as ‘categorical syllogism’, ‘premise’, ‘deduction’ and ‘validity’ may appear at first sight to be inscrutable but will easily be understood with examples bringing the subjects to life. Traditionally, Venn diagrams have been employed to test arguments. These are very useful but their application is limited and they are not open to quantification. The mid-section of this book introduces a methodology that makes the analysis of arguments accessible with the use of a new form of diagram, modified from those of the mathematician Leonhard Euler. These new diagrammatic methods will be employed to demonstrate an addition to the basic form of syllogism. This includes a refined definition of the terms ‘most’ and ‘some’ within propositions. This may seem a little obscure at the moment but one will readily apprehend these new methods and principles of a more modern logic.

Finally, a caution. It can often be perceived in books on logic a competitive theme: ‘how to win arguments’, ‘how to defeat your opponent’, or ‘how to be convincing’. If one is seeking this then one must look elsewhere, for this is not the sentiment here, quite the contrary. Logic here is seen as a mental tool that enables one to think clearly, to make better decisions and eliminate bad arguments, especially if they are one’s own. Although the ‘truth’ is an elusive concept it is nevertheless thought here to be worthy of pursuit and logical thinking will help achieve this without denigrating others.

Traditional Logic and the Categorical Syllogism

The earliest writings on logic probably came from Aristotle (384 – 323 BC) and these have proved remarkably resilient. There have been refinements and additions to his pioneering work but he must be credited with the formation of a fundamental argument called the categorical syllogism. It is called categorical because its components must be unequivocal and unambiguous and the term syllogism comes from the Greek for reasoning or inference. This is really the foundation to logic and its most simple form will be illustrated here. Later in the book there is to be demonstrated an extension to the types of syllogisms available, but for now what exactly is a categorical syllogism?

A categorical syllogism is also considered to be deductive, which means that the conclusion necessarily follows from the premises. In other words one cannot accept the premises as true but deny the truth of the conclusion. It is a form of argument but it is not the type of argument that involves a slanging match or a verbal competition between opponents. Rather, a categorical syllogism is an argument which in its simplest form has two premises and a conclusion. The premises contain information that can be extracted to form a conclusion, which may be obscure at first sight. Aristotle laid down some rules to the exact formation and relationship between premises and the conclusion. First, what is it that constitutes a premise?

A premise is traditionally a statement or proposition which could either be true or false. For instance, ‘Jennifer is a vegetarian’, is a statement that is either true or false. Whereas, ‘are you a vegetarian?’ or ‘do not eat meat’ are not recognised as premises as they are neither true nor false. A premise normally has a subject, which in this example is ‘Jennifer’ and a predicate which is ‘vegetarian’. The predicate tells us something about the subject. The first premise in a categorical syllogism is called the major premise and the second premise is the minor premise.

An example of two premises of a categorical syllogism:-

All vegetarians do not eat chicken kebab. (Major premise)

Jennifer is a vegetarian. (Minor premise)

Here are the premises but the syllogism is not complete because the conclusion is required. What conclusion can be deduced from these premises?

All vegetarians do not eat chicken kebab.

Jennifer is a vegetarian.

Therefore, Jennifer does not eat chicken kebab. (Conclusion)

One may notice that the terms ‘Jennifer’ and ‘chicken kebab’ appear independently in the premises but are present together in the conclusion. What connects them is the term ‘vegetarian’ and by convention the connecting term is called the middle term. The predicate of the conclusion (chicken kebab) is called the major term and the subject (Jennifer) is called the minor term.

All vegetarians do not eat chicken kebab.
Jennifer is a vegetarian.
Therefore, Jennifer does not eat chicken kebab.

The middle term (vegetarian) should never appear in the conclusion of a valid categorical syllogism but the major and minor terms should do so. This is an important point to remember as it is useful when one is trying to identify invalid arguments. What can be tricky however is identifying the terms in a more complex syllogism.

Consider this next argument:-

Jennifer does not have a bicycle, motor cycle or motor car.
There is no public transport near to Jennifer's home.
Therefore Jennifer will have difficulties getting to her work.

The conclusion at first glance looks reasonable enough but does it hold logically? Well, no. If one examines the conclusion one will notice the predicate 'difficulties getting to her work'. Where does this come from? It is not stated in either premise but now it is in the conclusion. Additionally, which is the middle term? 'Jennifer' appears in both premises which suggests that it might be the middle term but 'Jennifer' also appears in the conclusion and as stated by Aristotle middle terms do not appear in the conclusion of a valid categorical syllogism. One can conclude therefore the argument does not take the correct form of deductive argument and one cannot be certain that the conclusion holds. If one thinks of it more, it could be that Jennifer gets a lift from neighbours, she works from home or that she is quite happy walking to work.

In traditional logic arguments are often evaluated with the employment of Venn diagrams. These are named after the British Logician John Venn (1834 – 1923) and will feature in almost every text book on logic one might encounter. Their form is usually two or three intersecting circles, as shown below.

Venn Diagrams take this form:-

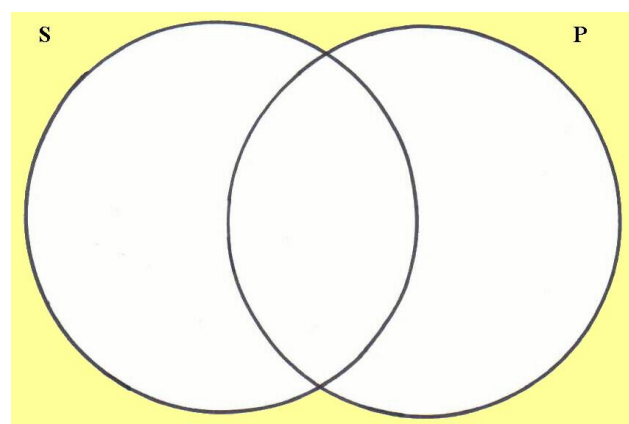

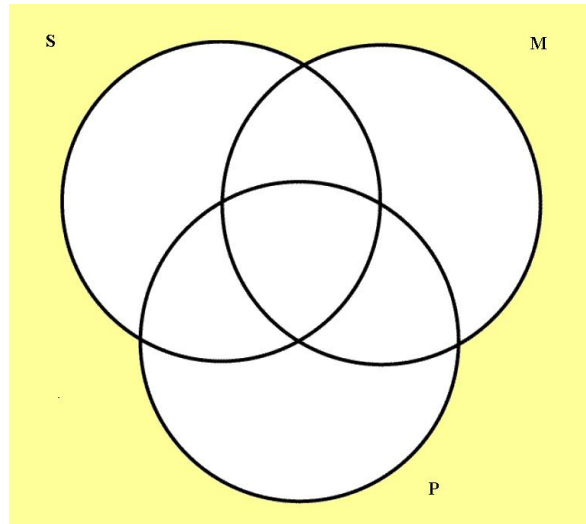

The letters S, P and M can represent the minor, major and the middle terms of a categorical syllogism.

Consideration of these diagrams is explored later but basically these will not be employed in this work as other forms of diagrams are to be explained and demonstrated. Nevertheless, Venn diagrams can be very useful for analysing arguments such as categorical syllogisms. These often take the form of two premises which are related and a conclusion but care is required as sometimes a premise is hidden or unstated. As mentioned before, if the premises are properly constructed within the rules of formal logic and both are true, then the conclusion deduced must also be true. This is known as a *sound* argument which also must be valid. One of the most important concepts in logic is ‘validity’ and this is often confused with ‘truth’. However, truth and validity are different things and it is important in logical reasoning to distinguish the differences. ‘Validity’ is to do with the logical form of arguments rather than the truth of the propositions it contains. Nonetheless, if all the premises are true and the form of the syllogism is correct then the conclusion must follow as true also. This is known as a Sound argument. Arguments, however, can have true conclusions but are invalid. On the other hand, arguments can be valid even if the premises and the conclusion are all considered false. Let’s consider some examples to bring the differences to light.

Example of a *sound* categorical syllogism:-

All newspapers have a political bias. (Premise 1)
 The Daily Telegraph is a newspaper. (Premise 2)
 Therefore the Daily Telegraph has a political bias. (Conclusion)

Example of a valid categorical syllogism that is not *sound*:-

All men have three legs and three eyes. (Premise 1)
 Queen Victoria was a man. (Premise 2)
 Therefore Queen Victoria had three legs and three eyes. (Conclusion)

Although the conclusion follows validly from the premises the argument is not sound because the premises are false. The conclusion is false too.

Example of a categorical syllogism that is not valid or *sound*:-

Some footballers are paid high salaries. (Premise 1)
Barry is paid a high salary. (Premise 2)
Therefore Barry is a footballer. (Conclusion)

Although the conclusion may possibly be true it does not follow from the premises. Some footballers receive high salaries but not all high salary earners have to be footballers.

Example where both premises and conclusion may be true but the argument is invalid:-

All cats are mammals. (Premise 1)
No mammals are reptiles. (Premise 2)
Therefore, all cats are not amphibians. (Conclusion)

Example where both premises are false and the conclusion is true, yet the argument is valid:-

All pigs are birds. (Premise 1)
All sparrows are pigs. (Premise 2)
Therefore, all sparrows are birds. (Conclusion)

This last syllogism is probably the one that is most difficult to comprehend, how can the premises be false and yet the argument valid with a true conclusion? The important point is that the basic form is followed, i.e. *all S is P, all M is S, therefore, all M is P*. This will become clearer later when the use of symbols is expanded upon.

These then are a few examples of arguments that can be checked by using Venn diagrams. However, there are limitations to this method, logical reasoning goes beyond categorical syllogisms and Venn diagrams cannot analyse the following –

1. Arguments that contain multiple premises i.e. three or more.
2. Sorites, a series of propositions where the predicate becomes the subject and a new predicate is formed. Often of the form, all *A* are *B*, all *B* are *C*, all *C* are *D*, therefore all *A* are *D*.
3. Conditional Reasoning, which takes the form, as an example, if *p* then *q*. This type of reasoning is called ‘conditional’ because of the inclusion of the *if* word. These arguments are not considered as categorical syllogisms.
4. Traditional logic and Venn diagrams do not include the concept of ‘most’ within a proposition. *Most* is always converted to *some*. However, in this work the importance of *most* is introduced and explained.

5. Venn diagrams do not lend themselves easily to mathematical quantification and calculation.

6. Venn diagrams in some instances give controversial results.

There have been several attempts to extend Venn diagrams beyond the categorical syllogism but none have managed to embrace all of the types of reasoning mentioned in the six points above. Here a new approach will be explained that begins with diagrams introduced first by Leonhard Euler (1707–1783) but now extended in several ways. Before this however some clarification is required on different forms of argument.

Deduction and Induction

The logic examples and tests provided in this book are concerning arguments that are deductively valid. There is another form of reasoning where the arguments are 'inductive' rather than deductive. These inductive arguments take a different form from the syllogisms given above. One finds these types of arguments in science or in the law courts. There is never a case where an inductive conclusion is necessarily true. Inductive conclusions could be inconclusive and even false, but normally one takes them as true if they are supported by very good evidence.

For instance:-

Smith was caught running from the scene of the robbery.

Smith was found to have on his possession jewellery from the shop that was burgled.

Witnesses saw Smith throw a brick into the jewellery shop window.

The fingerprints on the brick matched those of Smith.

The Judge concluded that Smith was guilty of robbery.

Did the Judge draw the correct conclusion?

If the Judge drew an *inductive* conclusion then the judge is on good grounds as there is a lot of evidence to support his decision. This is normally sufficient in these matters. However, one cannot *deduce* that Smith was guilty, for there is always the possibility of unknown evidence. For instance, Smith could have been set-up, or the witnesses were mistaken and the brick stolen earlier from Smith's house by a person unknown to the court. Indeed, many a person has been convicted on what seemed overwhelming evidence at the time only to find evidence surface at a later date that brings the original conviction into doubt.

Probability

Consider the following inductive argument:-

All the swans observed in Britain are white.

All the swans observed in North and South America are white.

All the swans observed in India are white.

All the swans observed in China are white.

All the swans observed in Indonesia are white.

Therefore, all the swans in Australia will be white.

This is a classical inductive argument, as the evidence of the white colour of swans builds up with observation in so many countries worldwide one is tempted to conclude that swans will also be white coloured in Australia. The conclusion however is false as there are both white and black swans in Australia. So can one improve this type of argument? Consider the following:-

All the swans observed in Britain are white.
All the swans observed in North and South America are white.
All the swans observed in India are white.
All the swans observed in China are white.
All the swans observed in Indonesia are white.
Therefore, all the swans in Australia will *probably* be white.

This second argument is exactly the same as the first except that the word 'probably' is added to the conclusion. By doing so one has a conclusion that is not wholly universal, the inclusion of a probability leaves open the possibility that not all swans will be white. The curious thing that concerns the use of 'probability' in statements is that they are forward looking in time. For instance, if someone says 'don't go through the orchard there are a lot of wasps and they have already stung everyone who has walked there this week. If you go through the orchard the wasps will probably sting you also'. The person is warning of likely future events but there is no certainty that a person going into the orchard will be stung, only a probability. If several people were to walk through the orchard but did not get stung then they may be inclined to say that the conclusion that 'one would probably be stung by the wasps' was false.

The logician however, is primarily concerned with deductive arguments. With these the conclusion must be necessarily true if the premises are true and the structure or form of the syllogism follows the rules of logical argument. In the following section it will be observed how one can test arguments with the use of diagrams.

Beyond Euler

In this section diagrams will be introduced to help analyse arguments and test whether they are valid. Logicians refer to the boxes pictured here as 'sets', 'classes' or 'domains'. For example they may say that the class of socks (S) is contained within the class of pink things (P). S is called the subject and P is called the predicate.

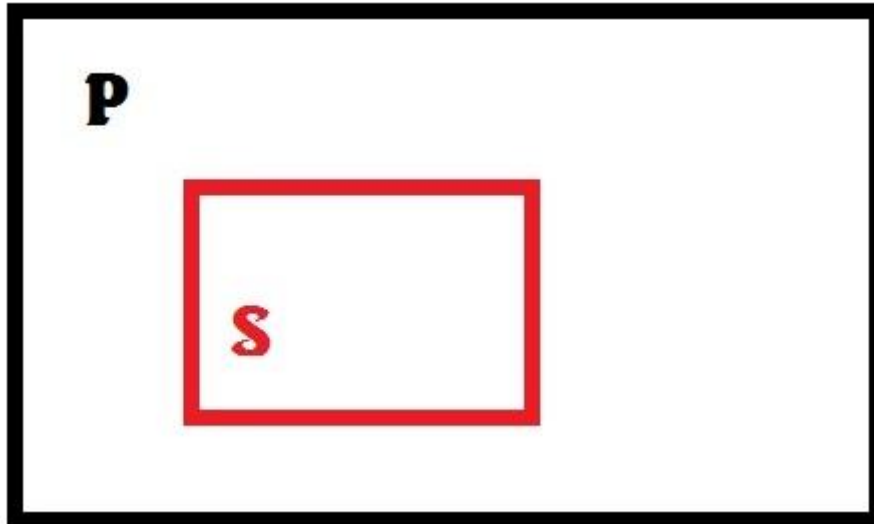

All S are P

This diagram represents that everything or every object that is S is also a P. For example this could mean that 'all the socks are pink' or that 'all dogs are mammals'. It is important to note however that not all P's are S's. It may be that all the socks are pink coloured but it does not follow that all pink coloured things are socks. Everything that is within the box S is a sock that is pink. Everything that is in the larger box P is pink and this includes pink socks.

The sentence 'all the socks are pink' is called a proposition or a statement. Propositions are sentences that could either be true or false. They differ from other sentences such as 'are you going to the zoo?' which takes the form of a question. Again, 'congratulations on your new relationship', which is a declaration. 'Give me some cake', is a directive. None of these sentences have a truth value, meaning they are neither true nor false and consequently they do not form part of syllogistic reasoning.

Propositions that take the form 'All S are P', do not always begin with 'All'. 'All' could be replaced with a noun or 'every', 'everyone', 'everybody', 'each', 'without exception', 'totally', 'wholly' and so forth. What links S with P (the subject and its predicate) is called a copula and this is a verb. The connective verb or copula 'are' is not always employed. It could be an 'is', for instance, 'Barry is a footballer'. This means that Barry is a member of the class of footballers. There are many copula, for instance, 'Barry *became* a football manager' or 'Barry, under pressure *took* drugs'.

This is called a Universal Affirmative Proposition and takes the form of:-

All	socks	are	pink
↓	↓	↓	↓
Quantifier	subject	copula	predicate

*One important point to remember, it does not follow from all S are P to all P are S . For example if one says all dogs are mammals then one cannot say all mammals are dogs. Dogs belong to the class of mammals but the class of mammals includes many other animals such as humans, whales and cats.

The Universe



Pictorial images can help one think logically. The picture above can represent the universe with planets, stars and comets. The box on the right hand side represents that all S are P . In other words the universe contains pink things and of those pink things there are pink socks. Outside of P (pink objects) there are no other things coloured pink, everything else is non-pink or non - P . One can also see from the diagram that there also are no pink socks outside P and in the remaining universe. This pictorial image can help one can make another deduction, this is that as all the socks are pink objects it follows that at least some of the pink objects in the universe are socks.

All S are P converts to at least *Some P are S* . In other words if there are pink socks there must be at least some pink things that are socks.

One has to be careful however with synonyms. Take, *all unmarried men are bachelors*. As the terms *unmarried men* and *bachelors* are interchangeable one has to use a different diagram:-

S or P

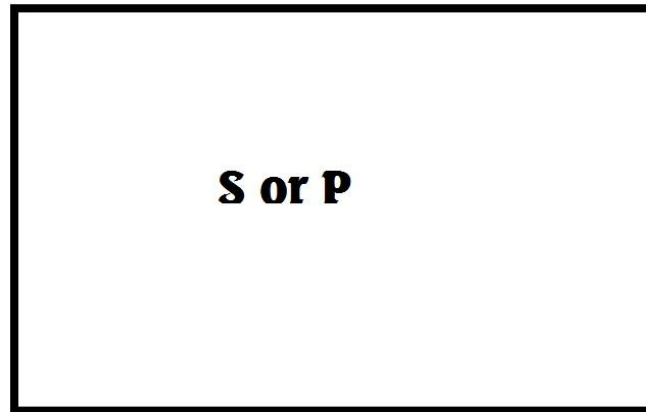

Here the subject and predicate are interchangeable. (One can use the \vee symbol in logic instead of *or*).

S and P

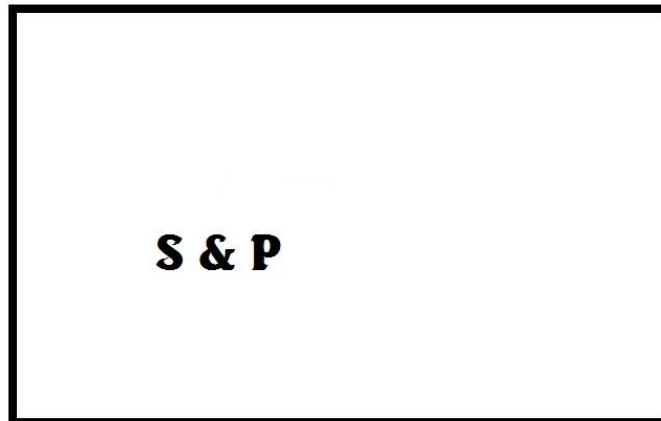

Here the predicate only applies to the subject and not to anything else. A proposition could also denote equivalence without being synonymous. Take, *all tall women are blonde haired and **only** tall women have blonde hair*. In the latter it is stipulated that nothing other than tall women have blonde hair. In the former however it does not exclude the possibility of short women and other creatures with blonde hair.

No S are P

This diagram below represents that everything that is S is not P. For example, *none of the socks are pink*, or *no dogs are reptiles*.

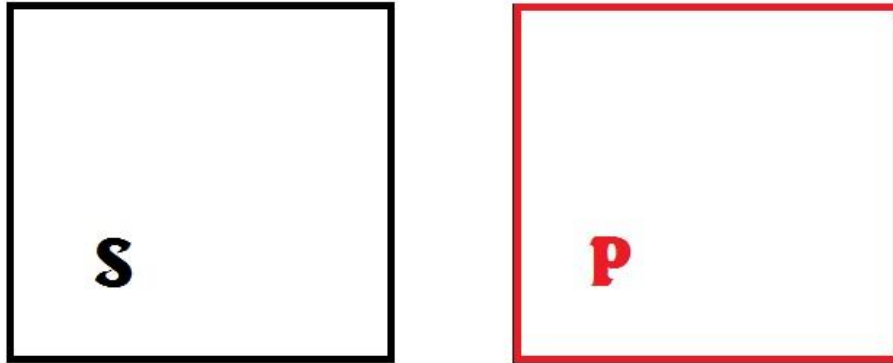

This is called a Universal Negative Proposition and takes the form of:-

No	socks	are	pink
↓	↓	↓	↓
Quantifier	subject	copula	predicate

Some S are P

This diagram represents that some of S have the quality of P. For instance, *some socks are pink* or *some dogs are fierce*. Notice an x has been placed where S and P overlap. This indicates that just some of the socks are pink or some of the dogs fierce.

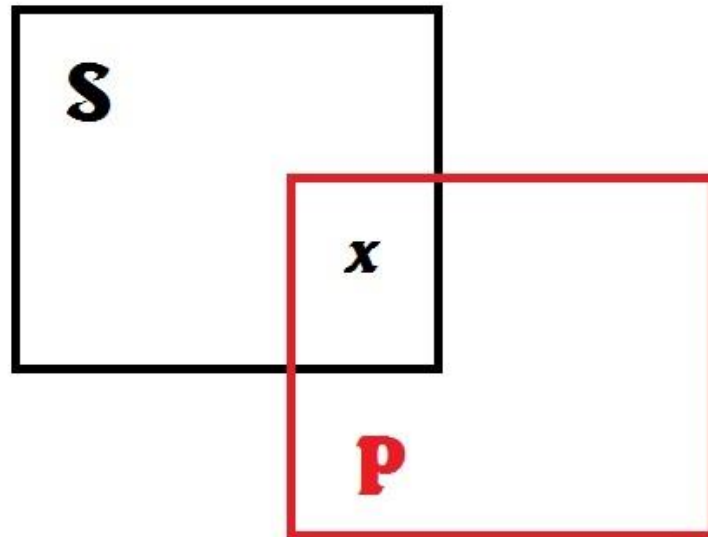

This is called a Particular Affirmative Proposition and takes the form of:-

Some	socks	are	pink
↓	↓	↓	↓
Quantifier	subject	copula	predicate

Some S are not P

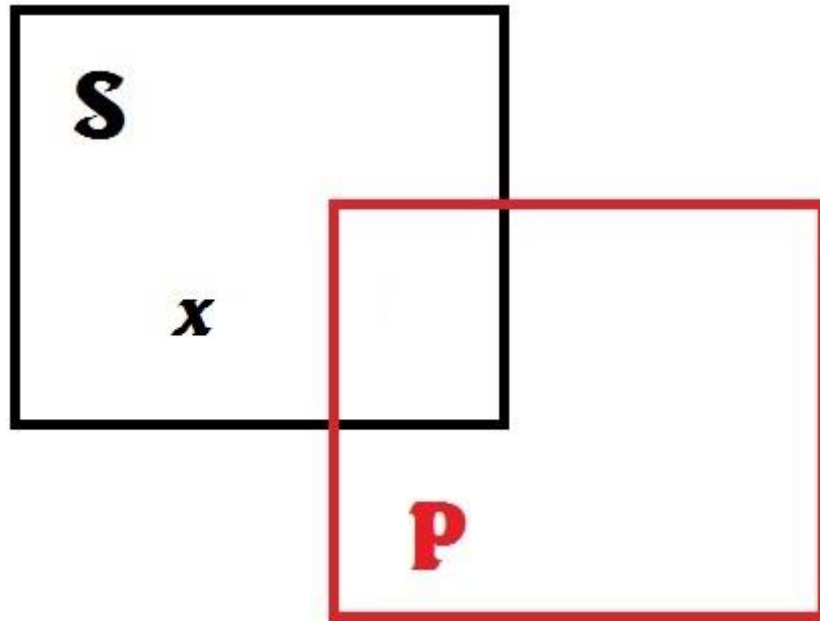

This diagram represents that some of S are not P. For instance *some socks are not pink* or *some dogs are not fierce*. Notice that an x has been placed in the S box but outside the P box.

This is called a Particular Negative Proposition and takes the form of:-

Some	socks	are	not pink
↓	↓	↓	↓
Quantifier	subject	copula	predicate

‘Some’

When one sees the quantifiers *all* or *no*, one quickly sees that everything is being included or excluded without exception. *All plastic is made of atoms*, or *no planets in the solar system are made of cheese* are both universal statements, one positive the other negative. Of course they could be true or false. It is logically possible that we have made a terrible mistake about the planets in our solar system and there is a planet somewhere made of cheese. Undoubtedly there are no Logicians that think there is a cheese planet but one must always hold in mind that universal propositions can be either true or false. One has to be careful in logic because the negative of *all* is *not all*. However, *not all* is never used in logical propositions because in English language *not all* is ambiguous and can mean *some*. Negative proposition usually start with the quantifiers such as, *no*, *none* or *never*.

When we see the word *some* in a proposition, what quantity springs to mind? This is less clear. In normal usage *some* is equivalent to *few* and contrasts to *most* or *many*. One does not think of *some* as the majority or as accounting for 99.9 per cent of something. Indeed, one usually thinks of *some* as being less than half or a minority, be it a large or small minority. In logic, however, *some*, is quantified as *at least one*. At times *some* is quantified as *at least one, possibly all*. There is another sense of *some*, for instance one might be eating an apple and another person might ask for *some* of it and then one complies by cutting and giving a small slice. *Some* can be considered therefore also as a part or section of something. Logicians traditionally do not recognise *most* or *many* as quantifiers. For instance, a proposition *most of the socks in the box are pink* would translate to *some of the socks in the box are pink*. This work will depart from this tradition and draw a distinction between *some* and *most*. From here on *most* will be defined as anything more than half but not all and *some* is defined as at least one or one part but not zero or nothing or even all.

Another difficulty with the concept of ‘some’ is when one is applying the negative ‘some p are not s’. For instance a person may say ‘*some of my exam results were not good*’ which seems to imply that the person’s other exam results were good. But does that follow? It could be that the other exam results were very very poor and far from good. Take another example, ‘*some of the socks in the drawer are not pink coloured*’. This does surely imply that some of the socks in the drawer are a colour different to pink. There is another sense of ‘not some’ that applies in some instances. Take a veterinary scientist who is examining the cows in a neighbourhood and after an initial testing concludes that from his sample at least some of the total number of cows to be examined do not have foot and mouth disease. His observation does not imply that the unexamined cows will not have the disease. Logicians do not therefore assume that ‘*some p are not s*’ implies that ‘*some p are s*’.

Most

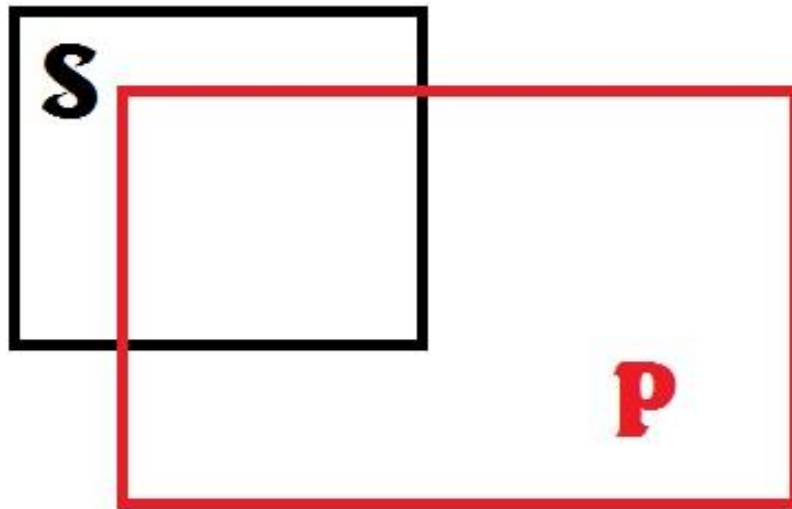

This diagram represents that most or over half of S are P. In other words *most of the socks are pink*. The box that represents the pink socks is drawn to cover more than half the area of the S box.

This is called a Particular Affirmative Location Proposition and takes the form of:-

Most	socks	are	pink
↓	↓	↓	↓
Quantifier	subject	copula	predicate

Most S are not P

This diagram represents that most S or the majority of S is not P. Most of the socks are not pink. The box that represents the pink socks is drawn to cover less than half the area of the S box. When one talks of 'most' S, does that imply that there is also 'some' S too? For instance, if one says '*I normally travel by car*', does that imply that there are some occasions, or at least one occasion, when one does not travel by car but by other means? Normally this connection is implied and it is taken here to be so.

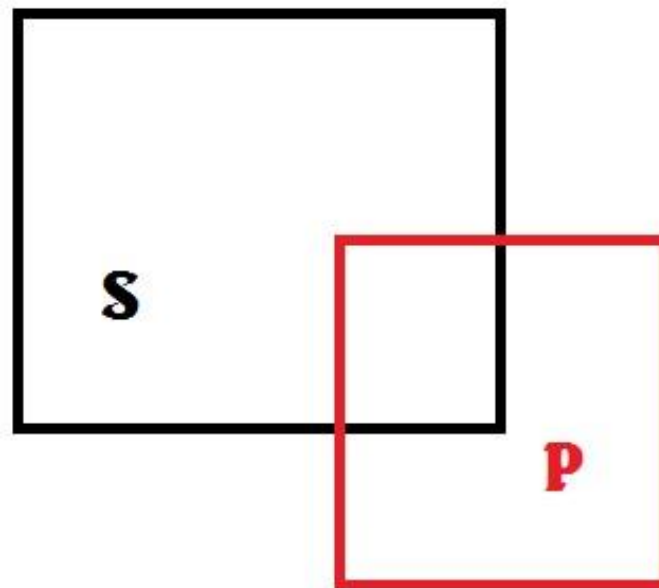

This is called a Particular Negative Location Proposition and takes the form of:-

Most	socks	are	not pink
↓	↓	↓	↓
Quantifier	subject	copula	predicate

Most P and Most Q within S

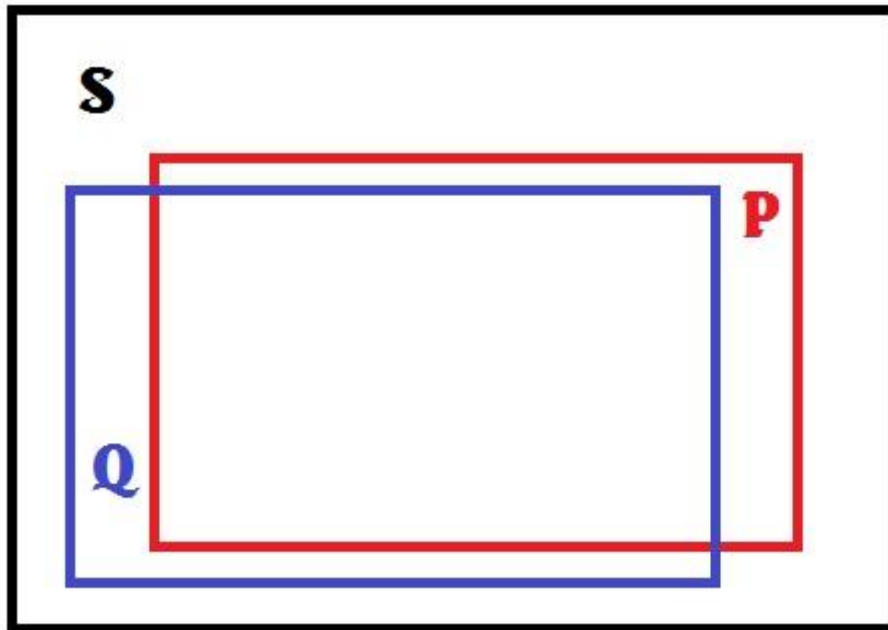

In this diagram one can see that Q and P overlap within S. Let S represent dogs in a kennel, Q represent that most of the dogs within the kennel are friendly and P represent that most dogs within the kennel are brown furred. What can one conclude from this? There is an overlap so the answer is that at least some of the dogs in the kennel are friendly and brown furred.

Most	Dogs	Kennels	are	Friendly/ Brown Furred
↓	↓	↓	↓	↓
Qty	Subject	Shared Predicate	copula	Predicate Not shared

It could be the case that all the friendly dogs are brown furred but one cannot conclude that. All one can conclude is that at least some of the dogs within the kennel are friendly and brown furred. Take another example:-

Most of the paintings in the museum are hung on the north wall.

Most of the paintings in the museum are portraits of women.

Therefore at least some of the paintings on the north wall include portraits of women.

Is this a sound argument where the conclusion follows from the premises? Let's add some figures to the argument to see if this is correct. Imagine one has ten pictures and of that ten eight are hung on the north wall and two on the adjoining west wall. Furthermore, of the ten pictures eight are portraits of women. It follows therefore that as only two pictures are hung on the west wall at least six of the portraits of women

are hung on the north wall. In this example one can deduce validly that *most* of the paintings on the north wall are portraits of women.

Imagine now that of the ten paintings six are hung on the north wall and four on the west wall. Furthermore, that six of the ten paintings are portraits of women. What can be validly concluded from this? Well, the four paintings on the west wall could all be portraits of women, so there would be two portraits in this instance on the north wall. One can conclude that *some* of the paintings (two in this example) on the north wall are portraits of women.

This type of syllogistic reasoning only holds where P and Q both share properties and differ in properties. In the first example both P and Q referred to dogs and these dogs are located in a particular kennel, having this in common. However, P and Q also differed; Q held the property of friendliness and P held the property of brown fur.

Most of S quantified

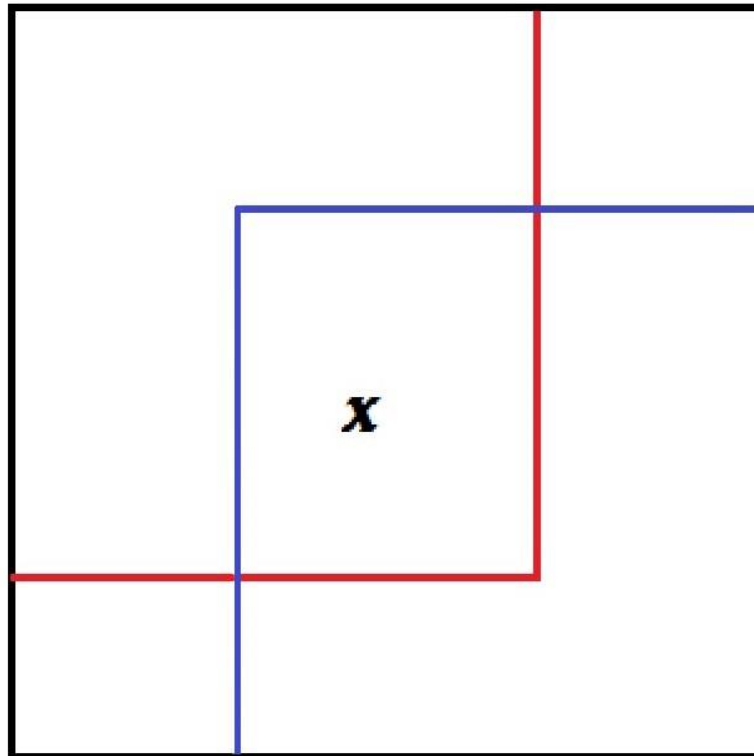

In this diagram the box S is divided by two parts, one red the other blue. The red part occupies seventy per cent of the box and the blue part also occupies seventy per cent. As both parts each occupy seventy per cent, there is an overlap. For instance, 70% of the socks in the box are red in colour and 70% are made of cotton. As there must be an overlap we can conclude that at least some of the socks are both red and made of cotton. In fact there are between 30-70 percent of the socks that are both red and made of cotton. It could be that all the socks are both red and of cotton but one cannot be sure from the information provided. The blue part in the diagram is drawn diametrically opposite to demonstrate the minimum overlap. One coloured area could be transposed directly over the other coloured area and this would demonstrate the maximum overlap. In this latter case all the socks in the box are both red coloured and made of cotton –

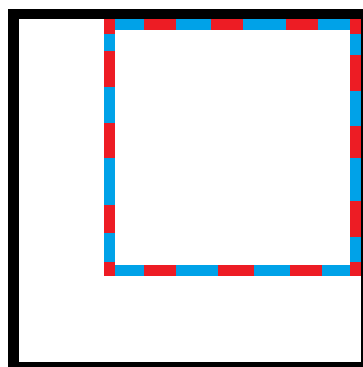

Testing Categorical Syllogisms with Diagrams

In this section one can see how the extended Euler diagrams can be used to test the various types of syllogisms for their validity. Remember, validity is not the same as truth. A syllogism may contain premises that are false, a conclusion that is false and yet still be valid. Take an example:-

George Orwell is a footballer.
All footballers live near the North Pole.
Therefore George Orwell lives near the North Pole.

This argument is valid because the conclusion must follow from the premises, even if the premises are quite obviously false. Logical reasoning is independent of truth and falsity if one accepts its rules. Sound arguments are considered to deliver true conclusions when the premises are all held to be true. The difficulty arises however, over the status of premises. Sometimes it is not clear whether a premise is true or false, there can be vagueness. Moreover, what one person believes to be true may not be accepted by another. For now though some testing of syllogisms will ensue.

Consider the following categorical syllogism for validity:-

All dogs are mammals.
All men are mammals.

Therefore all men are dogs.

How does one proceed? In the first premise *dogs* are the subject and *mammals* are the predicate. Notice also that the premise tells one that every dog is a mammal without exception. To begin we draw the class or set of dogs within the class of mammals –

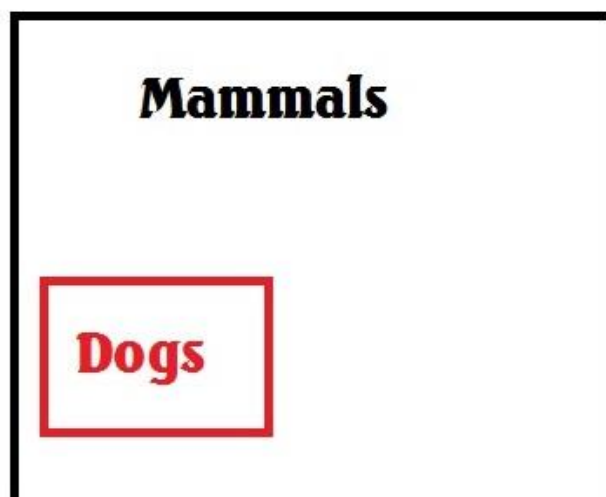

The next premise tells one that all men without exception are also mammals. So where does one draw this representation? Well all the premises indicates is that men are mammals so we can simply place them anywhere within the mammal box –

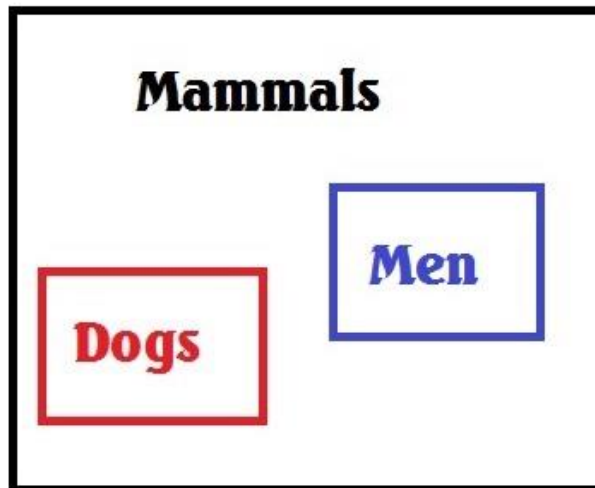

One can see from the diagram that the class of men can be placed within the class of mammals as prescribed in the second premise and yet independent of the class of dogs. For the syllogism to be valid one would have to place the class or box of men within or directly over the box or class of dogs, but as demonstrated there is no necessity to do so. This syllogism is therefore invalid because the diagrams demonstrate there is an alternative conclusion and one cannot draw either two contrary or contradictory conclusions.

Another example:-

All nuclear power stations are very safe constructions.
Fukushima is a nuclear power station.

Therefore Fukushima is a very safe construction.

Let's test this for validity.

Nuclear power stations are the subject and *safe constructions* are the predicate.

Therefore the diagram is as follows:-

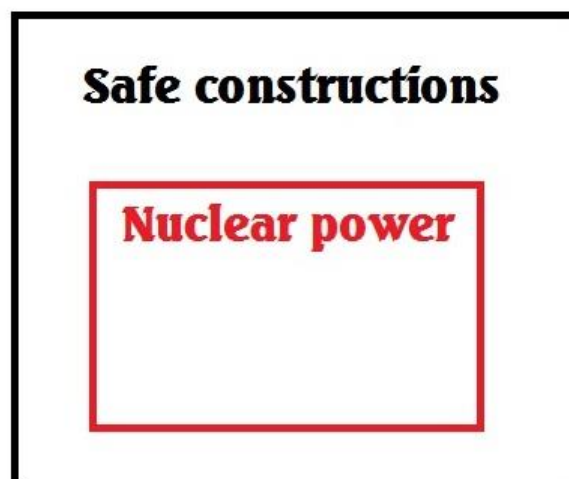

Now, the second premise states that Fukushima is a power station, so the box symbolising this is place thus:-



One can see that Fukushima is within the class of *safe constructions* and therefore the argument is valid. It was mentioned earlier that sometimes there are questions concerning the status of premises, is the premise true or false? Now prior to March 2011 the nuclear power stations at Fukushima were considered by many 'authorities' to be of the safest of constructions. Regretfully, we now know after the tsunami this optimism was wildly wrong. The premise, *all nuclear power stations are very safe constructions* is today considered dubious but previously this premise had been considered by many to be true.

The basics are now familiar; it is time to test some syllogisms that have within them at least two premises. Take the following:-

- P1. No birds are mammals.
- P2. No birds have fur.
- C. Therefore some mammals have fur.

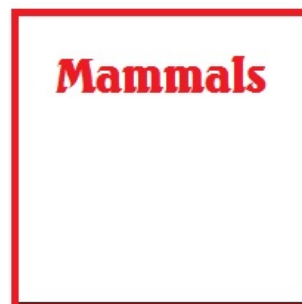
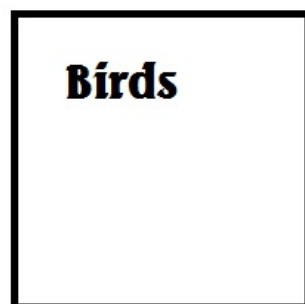

To test this syllogism one first draws a box for birds and then a separate box for mammals, as birds and mammals are of different classification. One then produces a second separated box for fur.

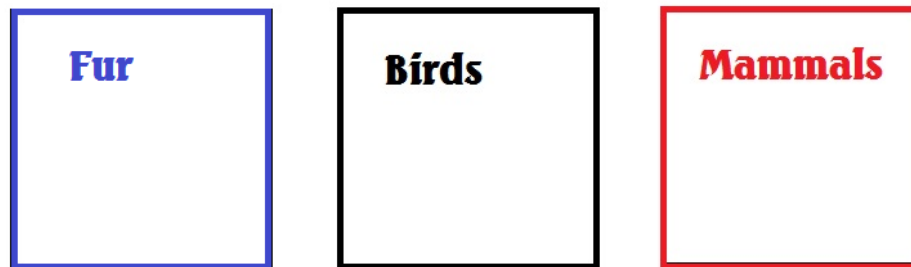

One could place the fur box outside the box for birds and overlapping the mammal box, however, given the information in the premises, one can also draw the box away from either box, as illustrated above. As one can do this the conclusion could also be that no mammals have fur, thus making the argument invalid. Notice that the premises are both true (as far as we know) and also the conclusion. This is the odd thing about logic, its primary purpose with all types of arguments is to determine validity or in other words, which conclusions can be legitimately drawn from the given premises. Logic does not tell us which premises are true and which premises are false, one has to establish that by other means.

Another syllogism to test:-

P1. Some birds are made of plastic.

P2. All birds have a beautiful morning song.

C. Therefore some things made of plastic have a beautiful morning song.

Stage 1

In premise P2 it states all birds have a beautiful morning song, therefore the box for birds is drawn within the box of things that have beautiful morning song. It is drawn in this form below to recognise that there may be other things that have a beautiful morning song.



Stage 2

In premise P1 it states that some birds are made of plastic, therefore a box is required that overlaps *birds* and *things made of plastic*. An *x* is placed to indicate that some birds are plastic. One can see from this that at least some of the things made of plastic must have a beautiful morning song. The argument is indeed valid.

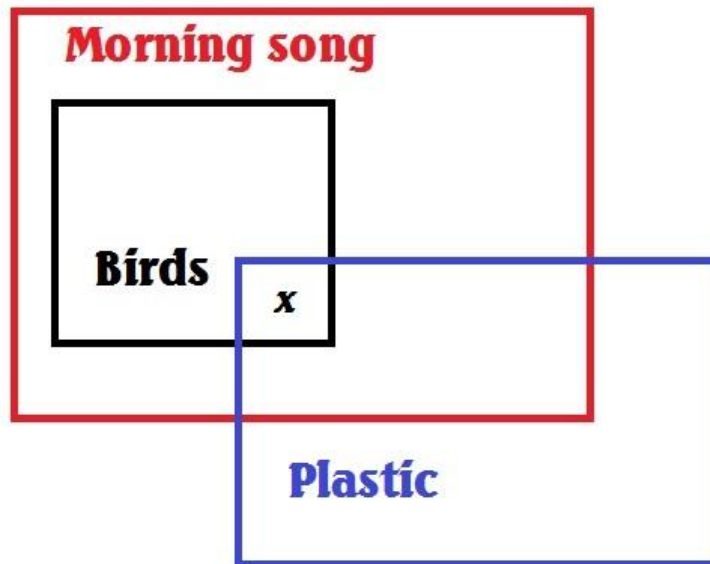

Another test-

- P1. Some dogs that escape their owners run very fast indeed.
- P2. Some criminals that run very fast escape also.
- C. Therefore some dogs are criminals.

The first premise states that some escaping dogs run very fast and this is represented in diagrammatic form to the left. Remember, the premise is not stating that *only* dogs that run fast escape their owners. Dogs could escape for other reasons. (One is of course assuming here that criminals are human and not dogs)

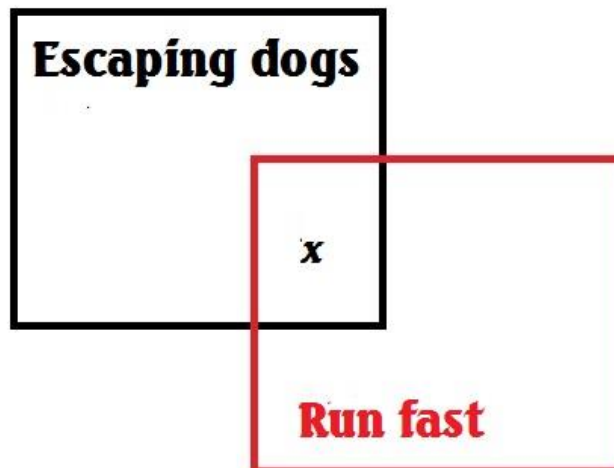

The second premise states that some escaping criminals can also run very fast, therefore, overlapping boxes are required to reflect this. One can see from the diagram there is no necessity to overlap escaping criminals with escaping dogs. The argument is, therefore, invalid.

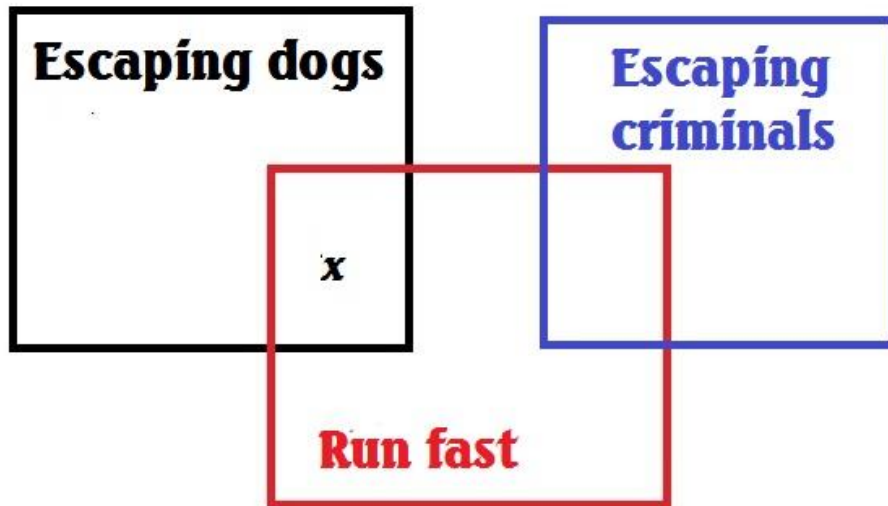

Let one suppose that the conclusion is, *Therefore some criminals are not dogs.* Is the argument now valid?

- P1. Some dogs that escape run very fast indeed.
- P2. Some criminals that run very fast escape also.
- C. Therefore some criminals are not dogs.

This becomes a little trickier; so more diagrams are necessary to test the validity of this new argument. The *escaping criminals* box (E.C) could be drawn as illustrated, overlapping the *run fast* box but within the *escaping dogs* box below (Fig A). This shows that *all* criminals are dogs and therefore the conclusion is not supported by the premises. However, the E.C box could also be drawn as partially in *the run fast box* as shown in Fig B. Remember, one only has to demonstrate that there are two or more possible conclusions to the premises to prove the argument invalid.

Possibility 1.

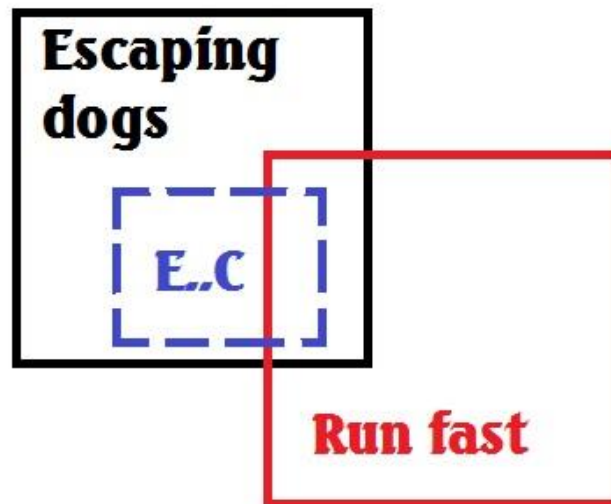

Figure A

Possibility 2.

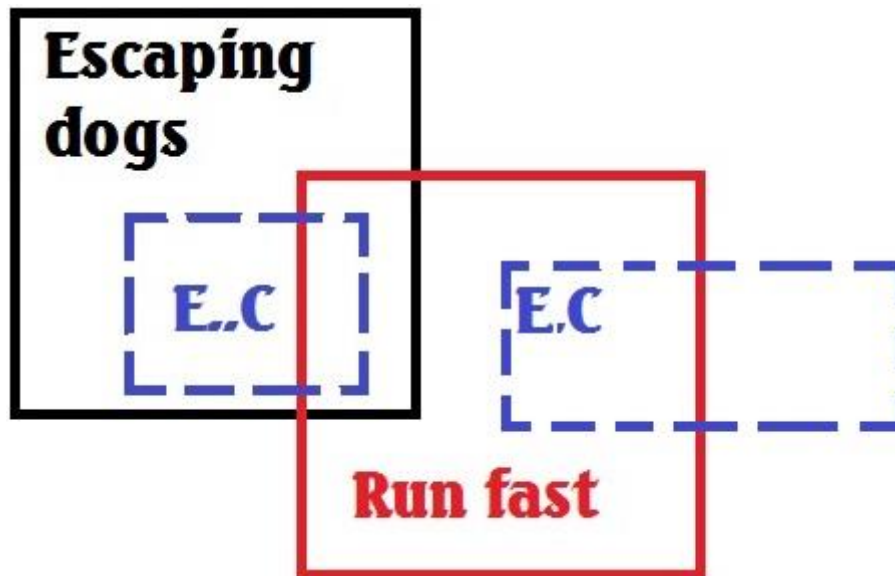

Figure B

Not all arguments fall neatly into a simple form of the categorical syllogism. Often they contain more than two propositions and they are more difficult to analyse for validity. One of the benefits of the extended Euler diagrams is that the more complicated non-categorical syllogism can be tested in a fairly simple manner, once one has grasped the methodology.

A slightly more complicated syllogism to test:-

P1. Solar energy produces barely any dangerous waste but nuclear power produces a lot of dangerous waste that lasts for thousands of years.

P2. All things being equal it is better to produce energy with as little dangerous waste as possible.

C. Therefore it is better to produce energy with solar power.

Separation of boxes is necessary here for P1 as this contains two statements. One represents solar power within *little dangerous waste*, the other represents nuclear power within *great dangerous waste*. P2 says it is better to produce as little dangerous waste as possible, so anything within *the little dangerous waste* box (this is abbreviated in the diagrams) satisfies this requirement.

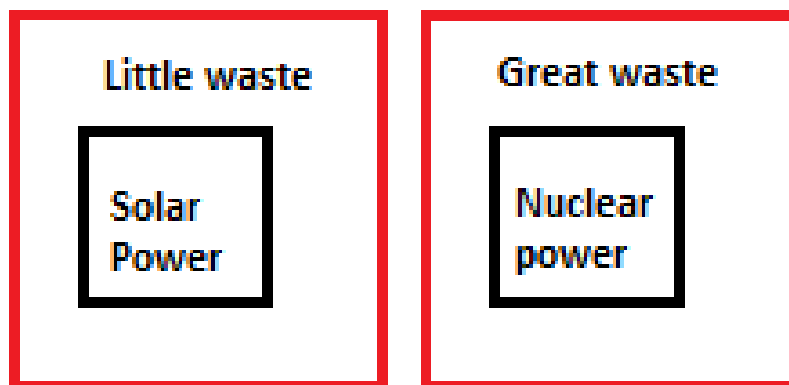

The second premises states that it is better to produce energy with as little waste as possible, therefore the diagram must reflect this -

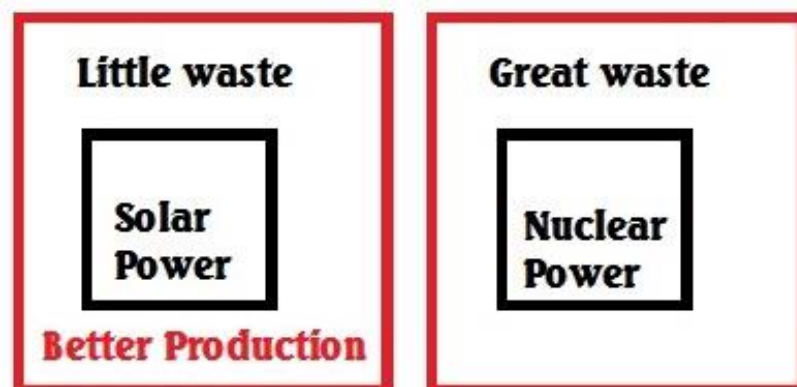

As 'solar power' is within the box the argument is valid and the conclusion holds.

Testing syllogisms with *most* in the premises.

P1. Most young women today in England have full time jobs.

P2. The majority of young women today in England have children.

C. Therefore, at least, some young women in England have both full time jobs and children.

The first premise states that most young women have full time jobs, one therefore draws a box to represent all young women and within that another box covering more than half the area to represent premise P1:-

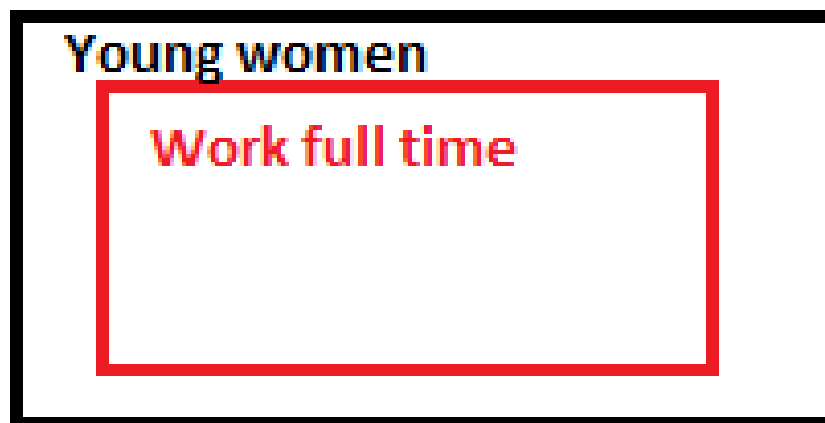

The second premise states that the majority of young women have children; one therefore draws another overlapping box to reflect this. It could be the case that one does not know for sure, that all the young women that work also have children.

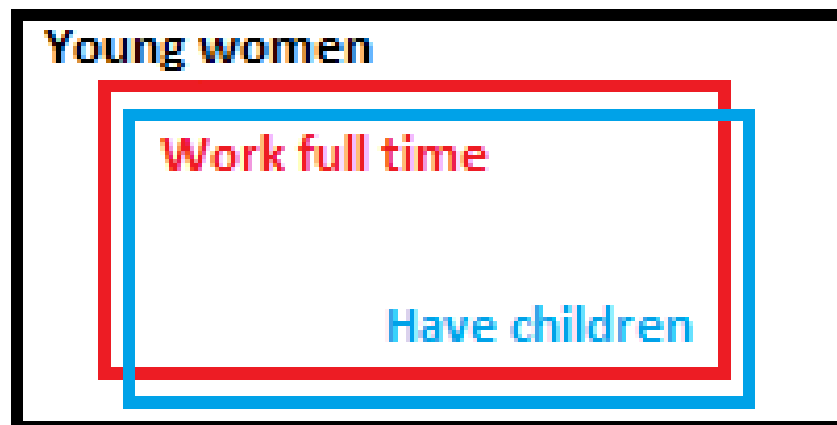

In the next test the premises change here to the obverse: –

P1. Most young women today in England *do not* have full time jobs.

P2. The majority of young women today in England *do not* have children.

What conclusion if any can one deduce from these premises? (Remember, *majority* and *most* are considered as synonymous). The diagrammatic form could look like these:–

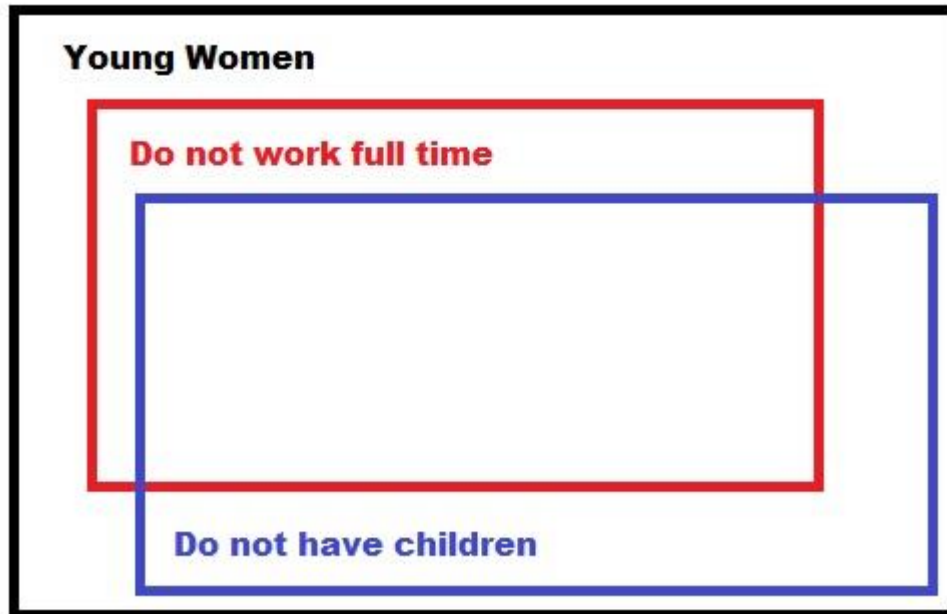

Remember, *most* is defined as ‘more than half’, therefore it follows that some young women have children and some young women have full time jobs. It does not follow necessarily that it is the same young women that do not have children that do not have jobs. This last point is illustrated above in the diagram above. The only conclusion one can legitimately deduce from the premises is that there are at least *some* young women who do not both have children and work full time.

So far arguments concerning *most* and with just two premises have been tested, now it is time to look at something more complicated. Consider the following:-

Recently a new zoo was opened in the south of France. It was rather expensive to set up, most of the animals cost more than two thousand Euros and special diets are required for the majority. A small percentage of the animals are allowed to roam freely within the confines but all the others require caging with safety in mind for the public. Most of the animals are quadrupeds with only a few non-quadruped species of Kangaroos and Wallabies. The Avery is yet to be built.

Conclusion: Therefore, we can deduce that within the zoo at least some of the quadruped animals were at least two thousand Euros to buy, requiring special caging for safety and specialised diets.

Is this conclusion a valid one?

To test this one has to identify the location, which is the zoo and then plot the different qualities or requirements of the animals. The key is to identify where the statement is referring to a quantification of more than half. As there is a lot of information it is advisable to abbreviate the different statements for each box one draws. Moreover, it can be beneficial to ensure each box with its abbreviation is the same colour. Below is a step to step diagram of how to proceed.

Stage 1

Draw box to represent the zoo animals (z)

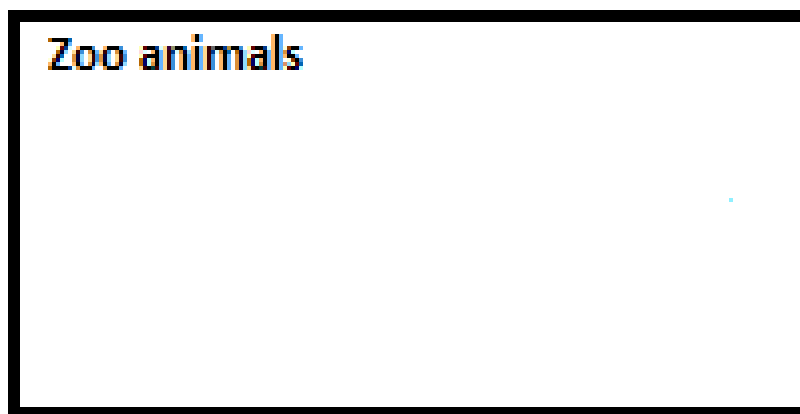

Stage 2

Draw box to represent the expensive animals costing more than 2,000 Euros (E). This box must cover over half of the area in the zoo box because most of the animals are expensive.

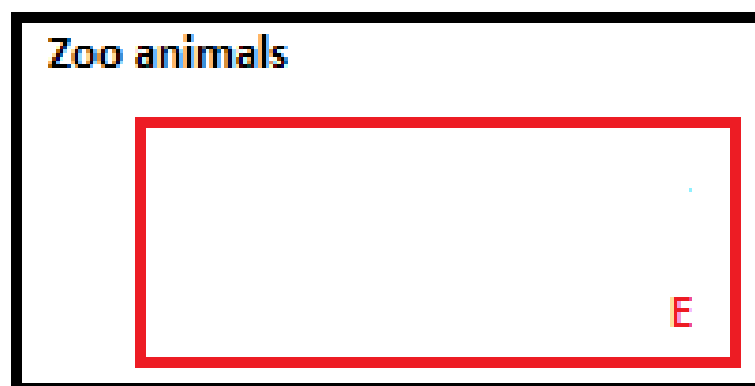

Stage 3

Draw box to represent the fact that most of the animals are quadrupeds (Q). Again, cover more than half of the area of the zoo box. For the sake of clarity do not try to draw the Q box directly over the E box but bear in mind it is a possibility that all the quadrupeds are expensive.

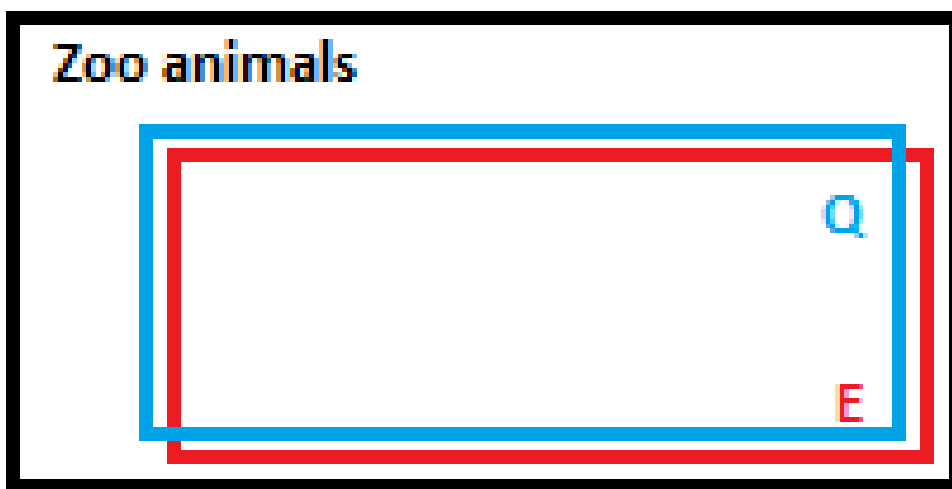

Stage 4

Draw an overlapping box to represent the fact that most animals require special Diets (SD)

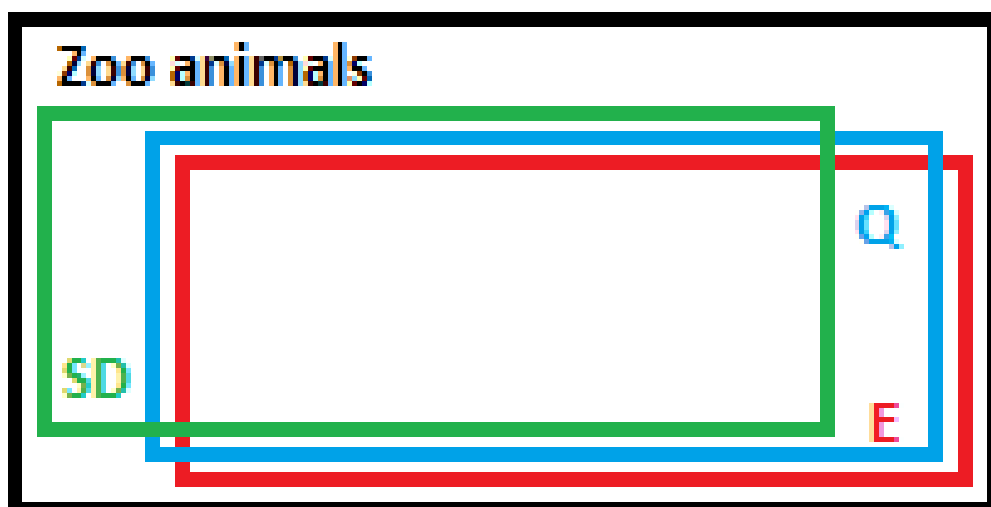

Stage 5

Draw an overlapping box to represent the fact that most animals require caging measures (C).

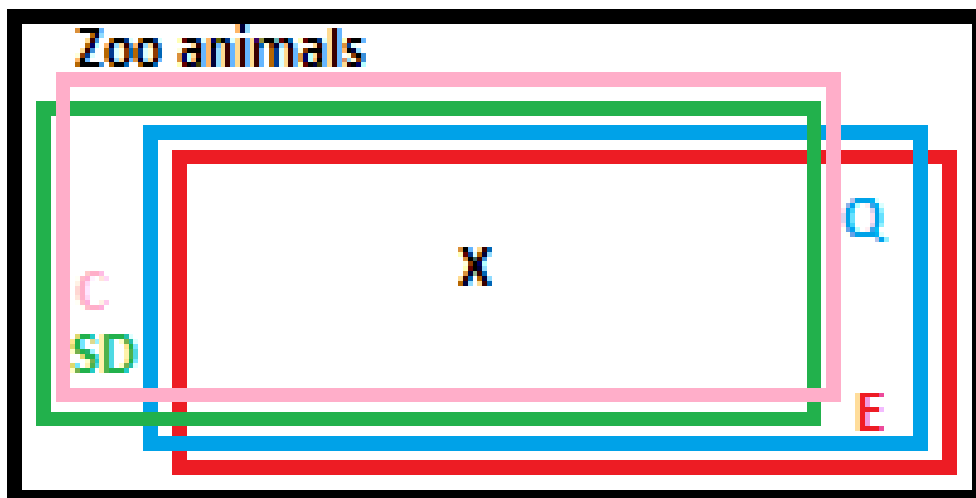

One can easily detect that within the zoo there are at least some animals that are quadrupeds, were expensive to purchase, require special diets and are needed to be caged. The **X** encapsulated where all the boxes overlap. It may be the case that it is just one animal or it could be the case that all the coloured boxes transpose in the same position indicating that most of the animals in the zoo have all the four listed characteristics. Remember, *some* is defined as at least one, so the deduction is valid. Moreover, if the premises are true then the conclusion must also be true and one has a sound argument. When drawing these boxes with multiple premises it is advisable to use large diagrams. One could draw all the boxes to cover only fifty one percent of the inner area but this would only make analysis more difficult.

The form this argument takes is like this: –

Within z

Most s is p

Most s is q

Therefore within z some s is both p and q.

If one is referring to things that are within the universe, for instance *most women become mothers* and *most women never go bald*, one can therefore drop the *within z*.

This is already implied in the premises. Arguments can be location sensitive however and this can lead to invalid arguments, more on this below.

The obverse formulation

Within z.

Most s is not p.

Most s is not q.

Therefore within z some s is not both p and q.

For example: –

Within the zoo, most animals are not carnivorous and most animals are not caged, therefore at least some of the non carnivorous animals are not caged.

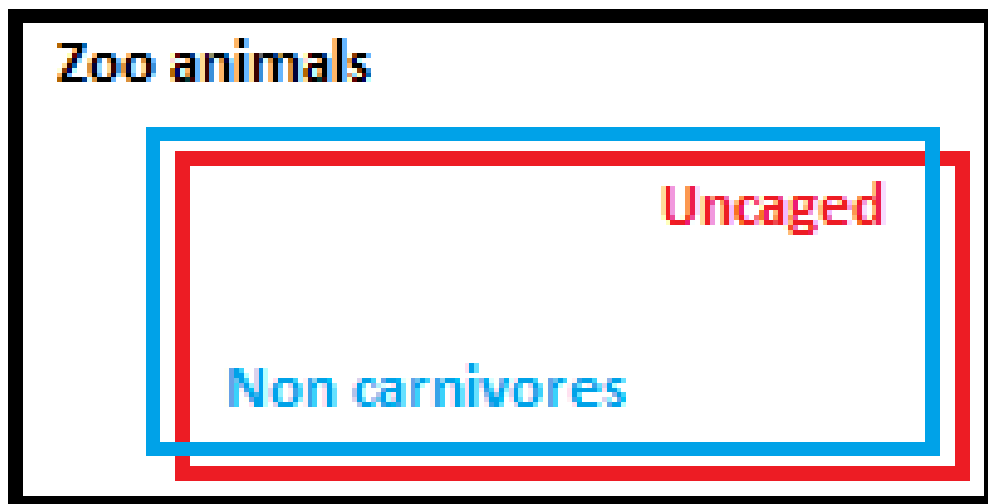

Remember also that it could be that all of the un-caged animals are the non-carnivores, but there is not enough information in the premises to conclude this.

Hidden Premises

Consider the following syllogism

Most cricketers go on winter holidays.

Most cricketers wear protective helmets.

Therefore some cricketers wear protective helmets on winter holidays.

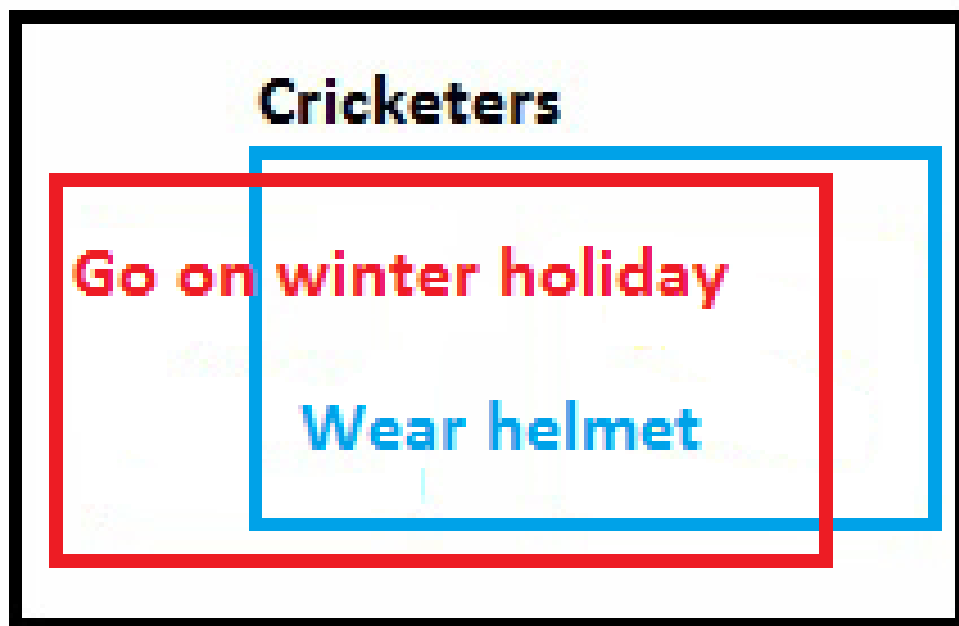

There is a problem here where the diagrammatic form demonstrates the argument above as valid, when in fact it is not what is probably intended. At face value one can conclude that some cricketers when on holiday are wearing their protective helmets. However, if one knows of the cricket practises then one can see a fallacy but if one knows little about cricket one might conclude the argument valid. The second premise is the problem. It should read something along the lines: *most cricketers wear protective helmets when facing hostile bowling or most cricketers wear protective helmets only when they are batting or close fielding*. Part of the intended meaning of the premise is unstated and hidden to the unfamiliar. If one is familiar with the game of cricket then one would recognise that when someone states that cricketers wear protective helmets they are describing an event in a particular context. It is not intended that cricketers wear helmets other than on the cricket field during play or practise. The location (and perhaps time) has to be taken into account. This, however, brings in problems of vagueness and what may be obvious and transparent to one person may be far from obvious and obscure to another person.

In traditional logic there are syllogisms that lack a premise or the conclusion is unstated, these are called an Enthymeme. The origin from Latin is *enthymema*, from Greek *enthymēma*, from *enthymeisthai* to keep in mind, from *en-* + *thymos* mind, soul. An example is, '*Did you see the way that man looked at you, he obviously fancies you*'. There is a missing premise here that should state that men who look at someone in a particular way indicate that they fancy that person. This would make the argument valid even if not true with such dubious premises. Another example is where the conclusion is unstated. For instance, '*you have been eating too many cream buns and pork pies, you know what that means*'. The undeclared conclusion is that under such eating habits one is likely to gain weight. With the Enthymeme there is often a fact or facts that are undisclosed but are shared between interlocutors.

Valid syllogisms of traditional logic

Traditionally it is recognised that there are fifteen basic forms of valid syllogisms. These are illustrated below, not with Venn diagrams but with Euler diagrams. In addition there are illustrated further valid syllogisms that have not been recognised in traditional logic but nevertheless are an important extension to logical method.

In traditional logic the premises and conclusion of a syllogism can be any of the four following types and represented by the letters **A E I O**:

- A** = All S are P (All – Universal Affirmative, ‘All dogs are mammals’)
- E** = No S are P (Exclusion – Universal negative, ‘No dogs are mammals’)
- I** = Some S are P (Inclusion – Particular Affirmation, ‘Some dogs bark’)
- O** = Some S are not P (Other – Particular Negative, ‘Some dogs do not bark’)

For an example one can examine AAA-1, this takes the structure as: –

All fish live in water.
All herrings are fish.
Therefore herrings live in water.

This valid syllogism has a middle term of ‘fish’ which is a subject in the first (major) premise but as a predicate in the second (minor) premise. This switch in position is recognised as the -1 in the notation AAA-1. It can be illustrated in a diagram like this:-

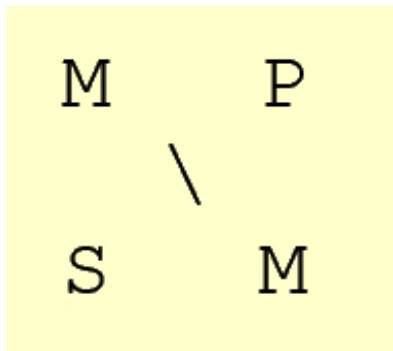

There are four possible ways the middle term can be distributed. If the syllogism takes the form, as an example, AOO-2, then this is illustrated thus:-

P	M
S	M

Any syllogism ending -3 such as OAO-3 can be illustrated thus:-

M	P
M	S

Finally, any syllogism ending -4 such as AEE-4 can be illustrated thus:-

P	M
	/
M	S

It is important to remember that the middle term never appears in the conclusion of a valid categorical syllogism.

Illustrations of Valid Syllogisms using Euler style diagrams.

All M are P. All S are M. Therefore, All S are P. (AAA-1)

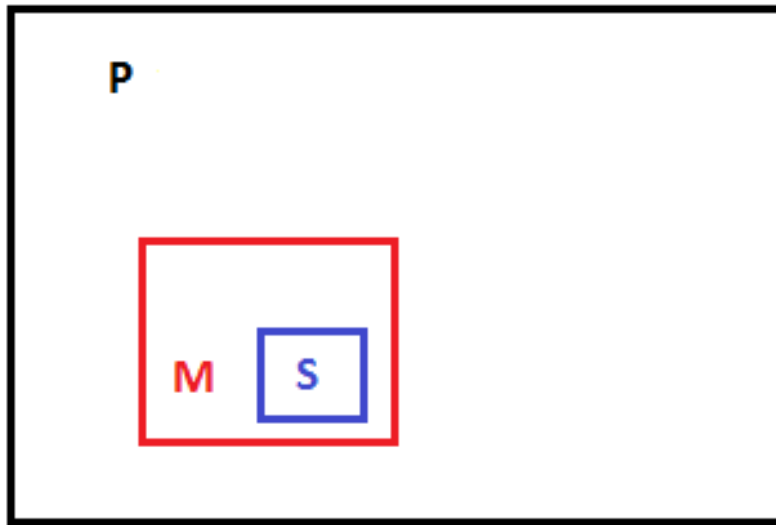

All P are M. Some S are not M. Therefore, Some S are not P (AOO-2)

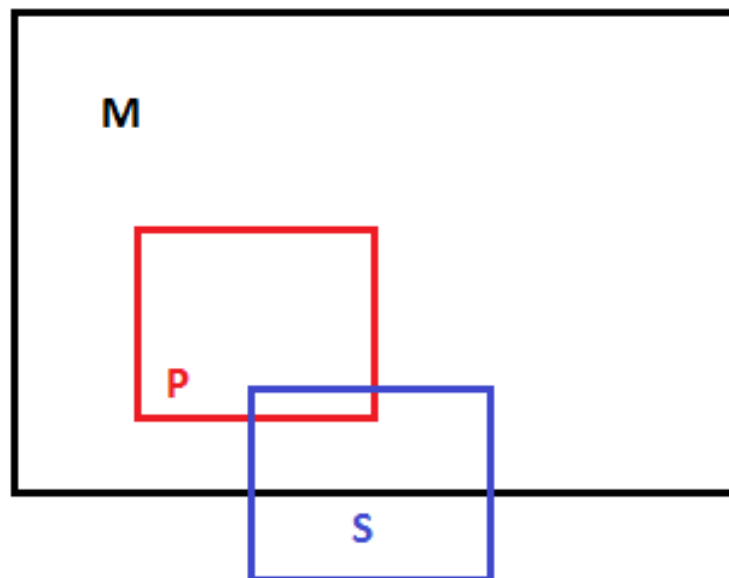

Some M are not P. All M are S. Therefore, Some S are not P. (OAO- 3)

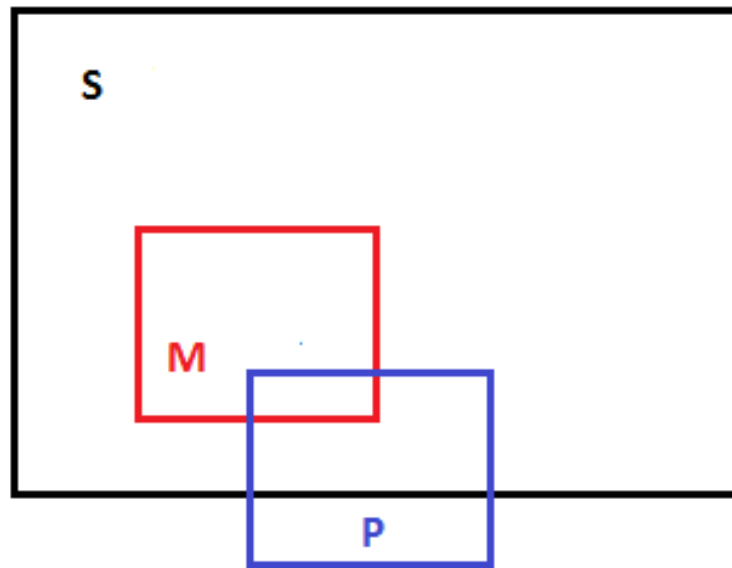

All P are M. No M are S. Therefore, No S are P. (AEE-4)

All P are M. No S are M. Therefore No S are P. (AEE-2)

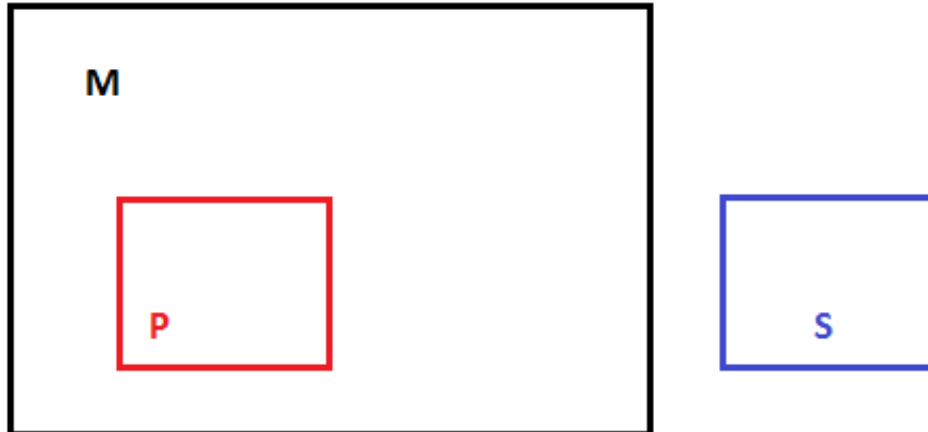

No M are P. All S are M. Therefore, No S are P. (EAE-1)
No P are M. All S are M. Therefore, No S are P. (EAE-2)

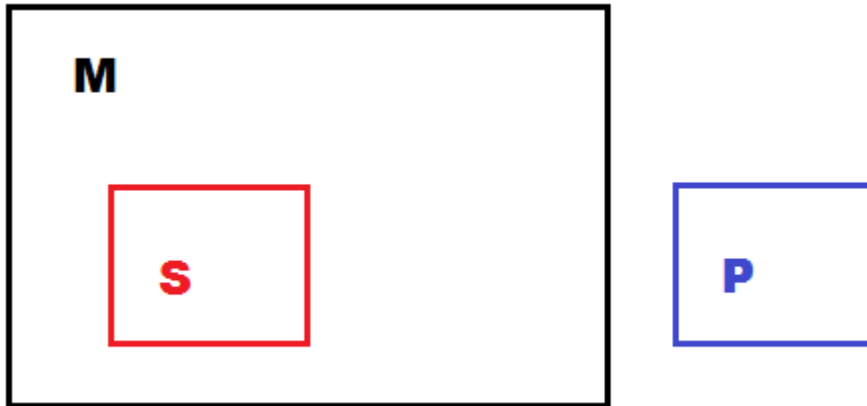

All M are P. Some M are S. Therefore, Some S are P. (A11-3)
All M are P. Some S are M. Therefore, Some S are P. (A11-1)

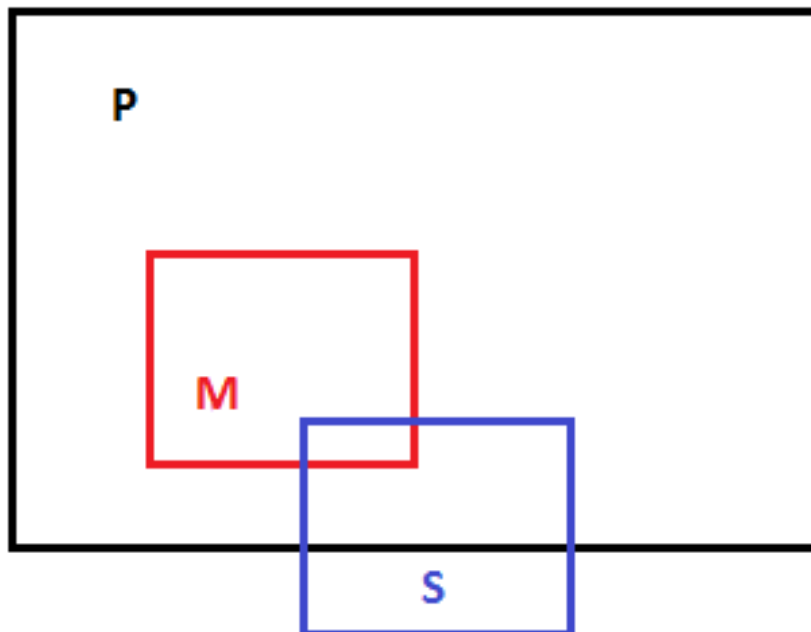

Some M are P. All M are S. Therefore, Some S are P. (1A1-3)
Some P are M. All M are S. Therefore, Some S are P. (1A1-4)

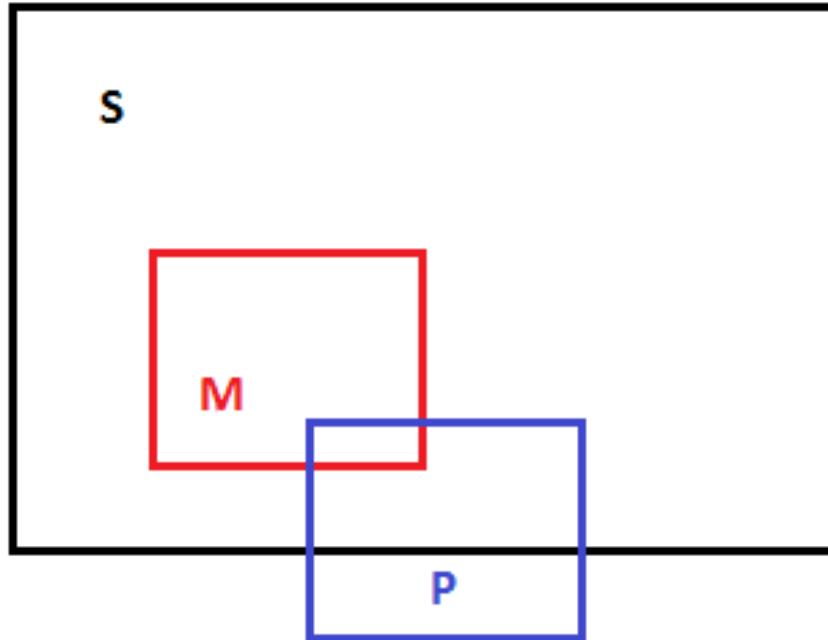

No M are P. Some S are M. Therefore, Some S are not P. (E10-1)
No P are M. Some S are M. Therefore, Some S are not P. (E10-2)
No M are P. Some M are S. Therefore, Some S are not P. (E10-3)
No P are M. Some M are S. Therefore, Some S are not P. (E10-4)

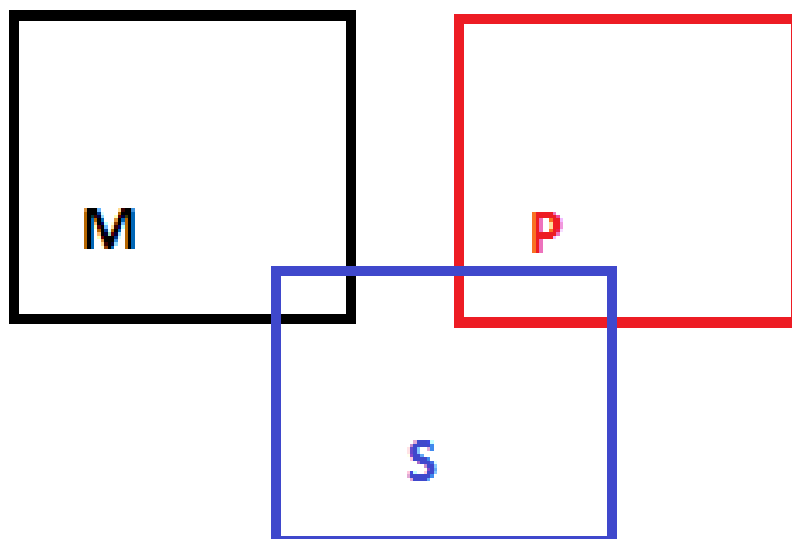

When analysing the diagrams representing particulars ('some' in the premise and/or the conclusion) one has to determine where the x is to be placed. For example take, *No M are P. Some S are M. Therefore, Some S are not P.* (E1O-1). Where would one place the x to show that *Some S are not P*? The answer is that one knows from that *some S are P*, so there is an x placed where the M and the S boxes overlap. Once in place one can see there must at least be one or more of S that is not of P .

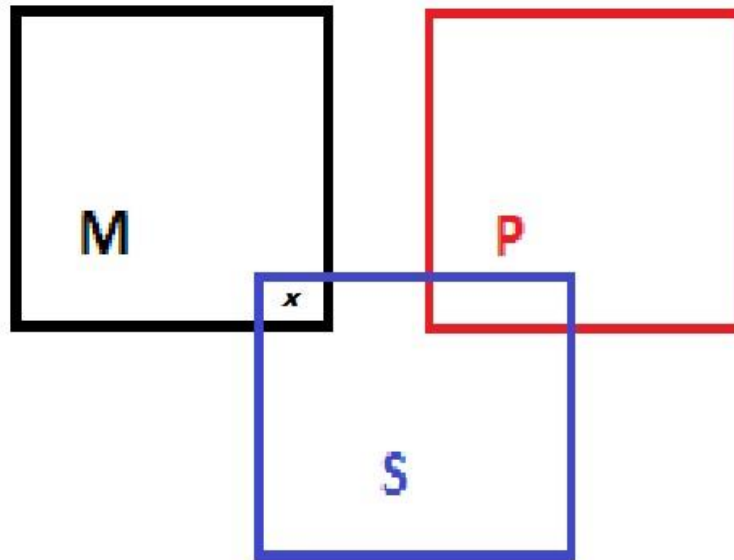

Exercise 1

Where is the x to be placed in the following: A11-1, E1O-2 and 1A1-4?
Tip: Identify the type of syllogism from those provided above.

Valid syllogisms of Modern Logic

In addition to the valid syllogisms of traditional logic one can now add the following:-

Most of P are S. Most of P are M. Therefore some of S are M.

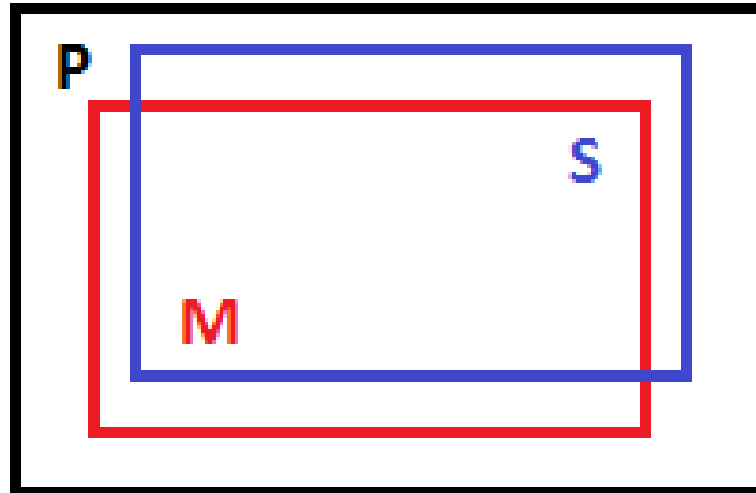

Most of P are S. Most of S are M. Therefore some P are M.

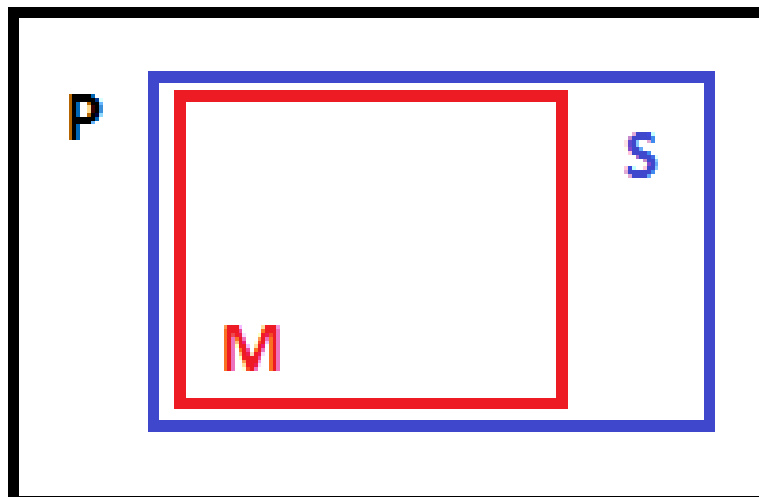

Most of P are S. Some of S are M. Therefore some P are M.

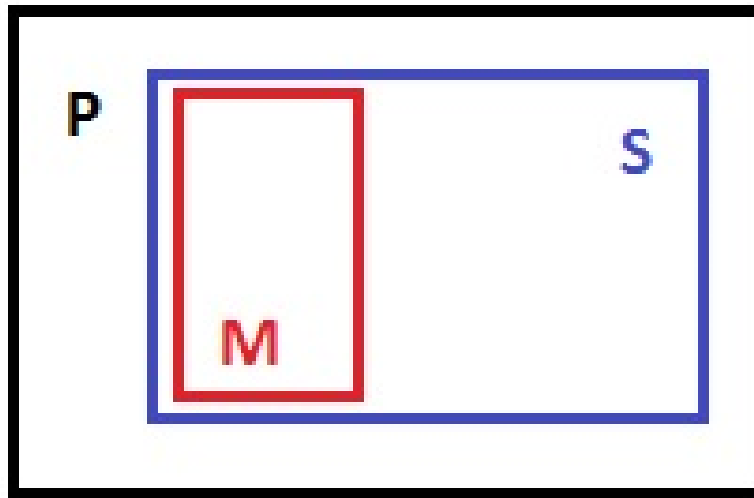

Unconditional and Conditional Syllogisms

It was noted above that there are fifteen forms of valid categorical syllogisms and this is accepted without controversy. There are however, another nine forms of categorical syllogism which have produced some discussion and debate. The debate centres over whether the subjects or predicates within the premises exist or not. There is another problem though and this is that some of the conclusions traditionally held could be incorrect when tested with either Venn or the modernised Euler diagrams.

First these are the nine so called 'conditional' syllogisms:-

No M are P. All S are M. Therefore, some S are not P. *EAO-1*

All M are P. All S are M. Therefore, some S are P. *AAI-1*

No P are M. All S are M. Therefore, some S are not P. *EAO-2*

All P are M. No S are M. Therefore, some S are not P. *AEO-2*

No M are P. All M are S. Therefore, some S are not P. *EAO-3*

All M are P. All M are S. Therefore, some S are P. *AAI-3*.

All P are M. No M are S. Therefore, some S are not P. *AEO-4*

No P are M. All M are S. Therefore, some S are not P. *EAO-4*

All P are M. All M are S. Therefore, some S are P. *AAI-4*

One might notice that all the premises are either positive or negative (no/all) universals and all the conclusions are positive or negative particulars (some). However, when one employs diagrams the results can be different. To begin one can consider the traditional use of a Venn diagram for syllogism AAA-1.

All M are P. All S are M. Therefore, some S are P

First stage uses 3 intersecting circles with the subject, predicate and middle term labelled:-

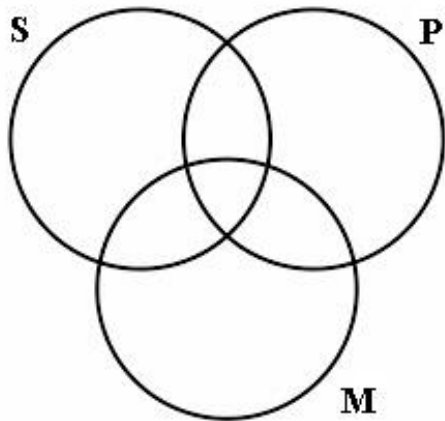

Second stage indicate the area where M and P intersect by shading out the parts of M that are not P. This indicates all M is P.

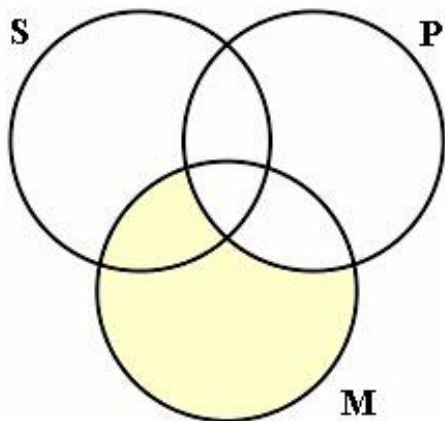

Third stage indicate the where S and M intersect by shading out parts of S which are not M. This indicates all S is M.

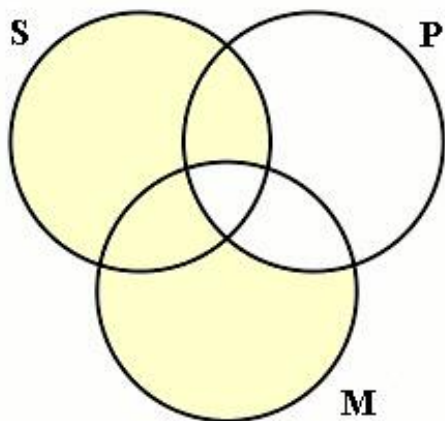

Final stage is to check if the conclusion, *some S are P*, is confirmed by the diagram.

One can see that there is indeed an area in the very centre where S and P intersect and remains unshaded. However, this demonstrates that **all** of S are P. Now, what is the result if we employ the modern version of Euler diagrams?

Stage one represents All M is P



Stage two is to represent All S is M

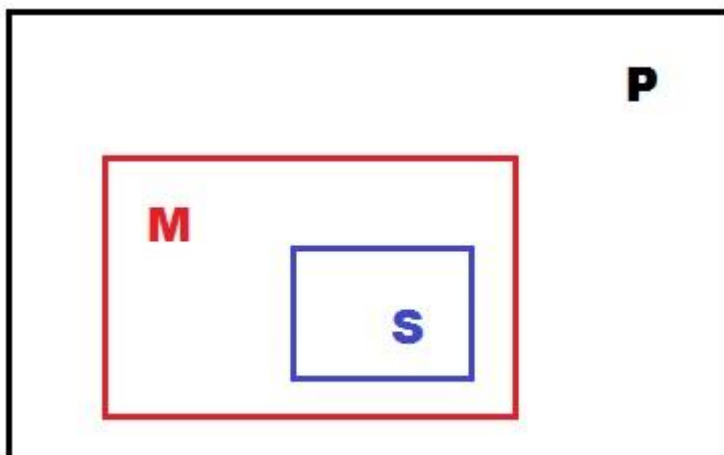

One can see from the diagram above that **all** S are P as reflected with the Venn diagrams and not **some** S are P. It may be worthwhile to convert these symbols to actual terms and see if this illustrates the situation.

All M are P. All S are M. Converting to:–

All mammals are animals.

All humans are mammals

Venn and Euler conclusion: All humans are animals.

Venn diagram:-

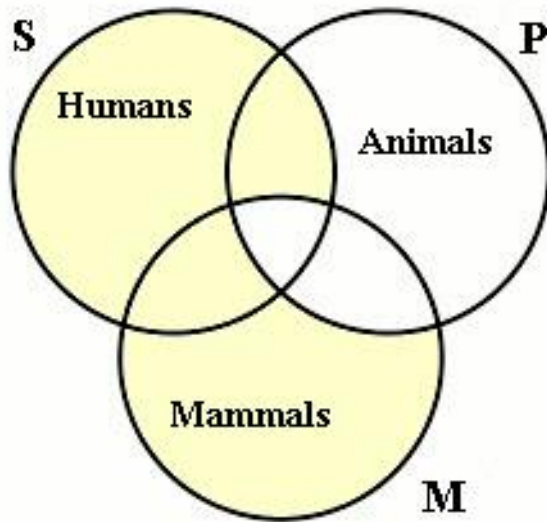

Modern Euler diagram:-

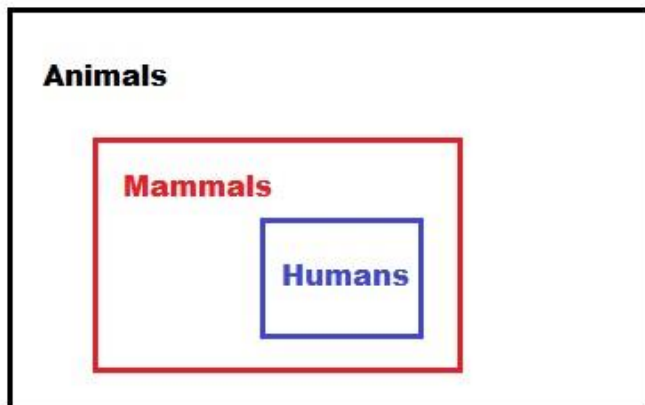

The conclusion that 'some humans are animals' or 'some humans, possibly all, are animals' is very odd and is not supported by either form of diagram. It seems to leave open the possibility there may be some humans that are not animals. If that were so the definition of 'human' would have to change to recognise that there may be humans that do not belong to the kingdom of *Animalia*. No serious Logician however would entertain the suggestion that biologists, on these grounds, should alter their taxonomic definitions.

Part of the debate concerning 'conditional' categorical syllogisms argues that they are valid if the terms of the premises exist and are not fictional. Accordingly, should hypothetical or imaginary terms be present in one premise or more then the syllogism is invalid. Consider this example:-

All Unicorns (M) are fictitious characters that appear in literature (P).
Matia (S) is a Unicorn (M).
Therefore Matia is a fictitious character.

Whichever form of diagram one uses, the result demonstrates the argument to be a valid syllogism and yet the terms include a non-existent Unicorn. Now one might argue that the Unicorn does actually exist but only as a representation in literature or storytelling. Consider, therefore, this syllogism and its diagrammatic form:-

All Unicorns (M) have a single spiral horn (P).
Matia (S) is a Unicorn (M).
Therefore Matia has a single spiral horn.

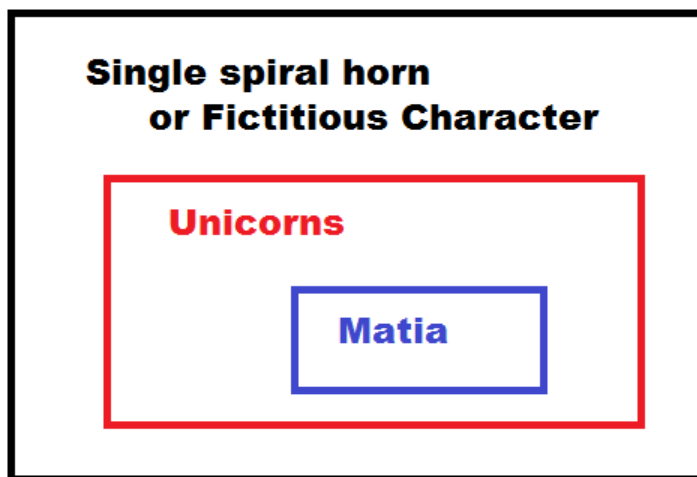

The form of this latter argument is the same form as the former, all that has changed is the predicate. It is difficult to see why the latter might be considered invalid. It may tell us nothing about the world and therefore, cannot be considered an empirically *sound* syllogism but that does not render it invalid. The lesson to learn is that valid arguments do not necessarily give conclusions that are true.

The other Conditional Syllogisms.

It was demonstrated above that both modern Euler and Venn diagrams gave the same result with the syllogism All M are P. All S are M. Therefore, some S are P (AA1-1). Does this confirmation follow for the others conditional syllogisms? Consider:–

All P are M. No M are S. Therefore, some S are not P. *AEO-4*
With a Venn diagram this takes the form:–

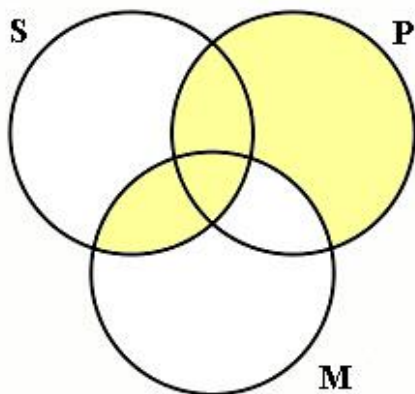

One can see that the unshaded area of S does not intersect with P, demonstrating that *some S are not P*.

However, if one observes the modern Euler diagram the result is somewhat different–

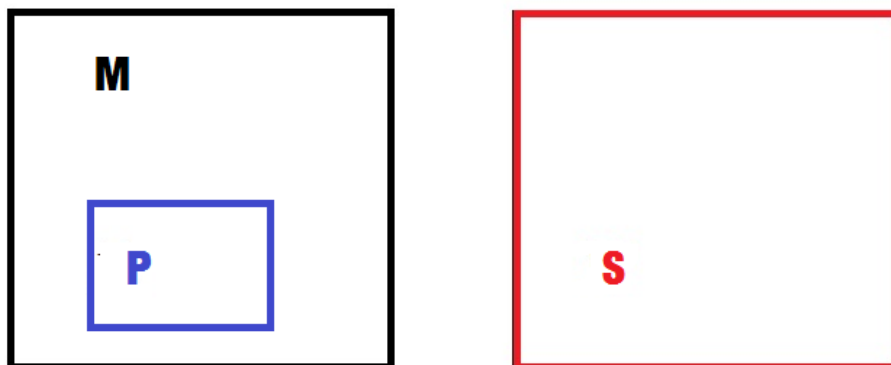

Everything that is a P is also M and no S is M. Therefore the conclusion with this diagram is that *no S is P*. This is a different result to the one provided by the Venn diagram. Which one then is correct, for they cannot both be?

Consider the substitution to words instead of symbols with the traditional conditional:–

All people are mammals.
No mammals are insects.
Therefore some insects are not people.

With the modern Euler interpretation:–

All people are mammals.
No mammals are insects.
Therefore no insects are people.

Once again the conclusion that ‘some insects are not people’ is very odd and does not reflect the facts of biological taxonomy as are prescribed today.

Exercise 2

Which of the nine conditional syllogisms above differ in conclusion if analysed with modern Euler diagrams?

Sorites

All S are P and all P are Q

The origin of the word 'sorites' is from the Greek meaning a 'heap'. They are a series of premises, chain like, that make up a polysyllogism. Usually the predicate of the first premise forms the subject of the subsequent premise. These cannot be represented by Venn diagrams but do lend themselves easily to modern Euler ones.

Sorites usually take the form along the lines 'A precedes B and B precedes C then A precedes C'. The diagram below represents that everything that is an S is also a P. Moreover, all that is a P is also a Q. For instance, one might say the socks are in a parcel and the parcel is in the queue for the deliveries. From this one can deduce that if the parcel is in the queue then the socks are also in the queue as they are inside parcel.

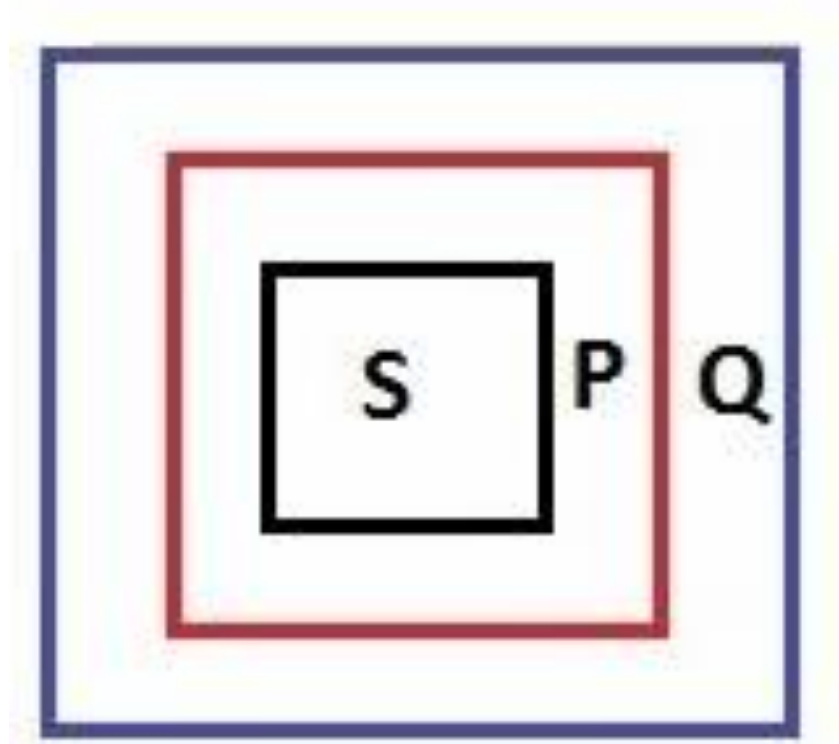

Another example, John is heavier than Jim and Jim is heavier than James, therefore John is heavier than James. Sorites can be quite extensive, below is an example in biological taxonomy-

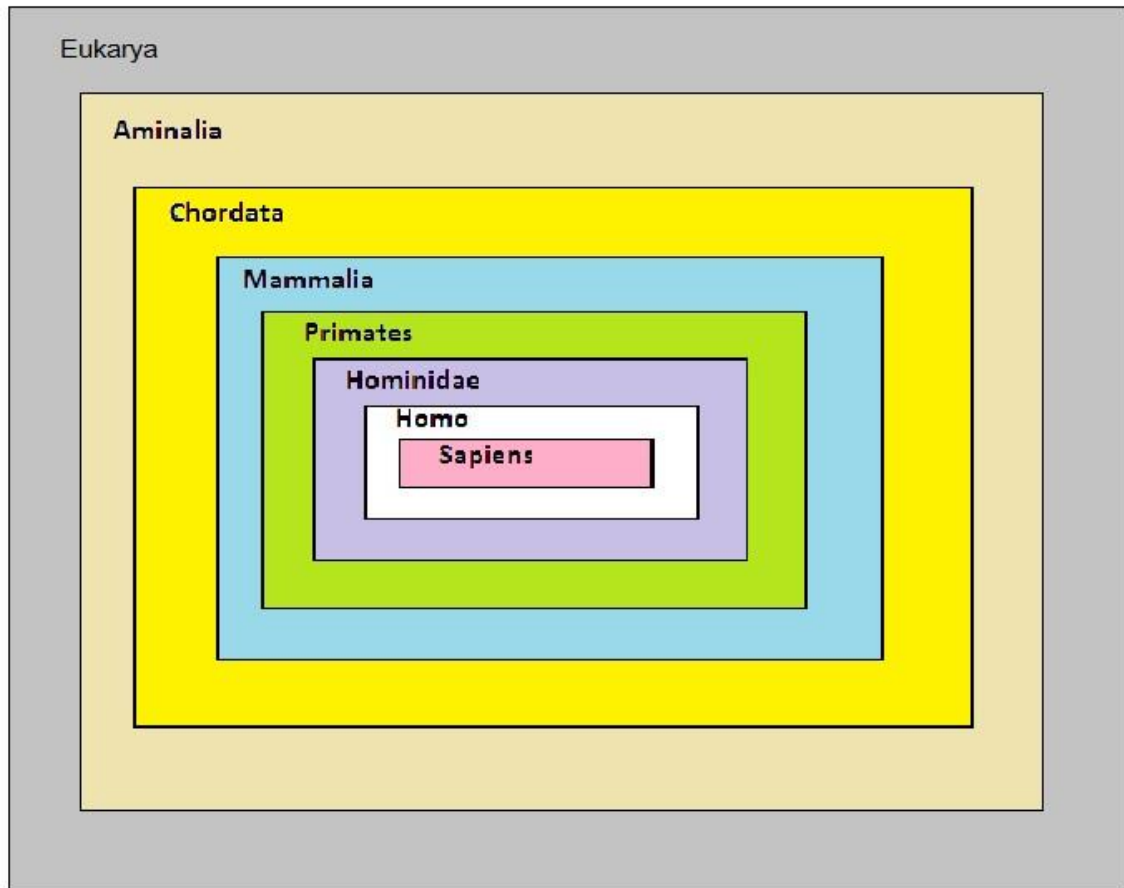

This diagram represents the taxonomy for human beings or *homo – sapiens*. All *homo-sapiens* belong to the genus *Homo* which itself belongs to the family of *Hominidae*. In turn all *Hominidae* belong to the order of *Primates* and so forth. One can quickly see for example that all primates are animals and as all primates are animals, it follows that all humans are animals as all humans are primates. Logicians are interested in the relationship between these different groups and what is entailed by what. The taxonomy may be incorrect or inaccurate but that is not the primary concern here. The facts provided by the biologists are taken as given, it is the relationships between these orderings that is scrutinised by Logicians. If someone said, for instance, that *all primates are mammals therefore all mammals are primates*, we know that is an invalid argument. Looking at the diagram we can see that indeed all primates are within the box named mammals but the box of mammals may include other creatures. On the information here we do not know for sure, therefore a firm conclusion cannot be drawn. Of course in nature there are many non-primates that are mammals, such as cats, dogs and whales.

A is shorter than B, B is shorter than C.

When one is comparing measurements one can employ this diagram to determine relationships. One can see that if A is shorter than B and B is shorter than C then it follows that A is shorter than C. The advantage of using rectangular forms is that they can be precisely quantified and drawn to scale. For instance, the first premise is that B is 60 per cent shorter than C and the second premise A is half as tall as B. What conclusion can be deduced from the premises?

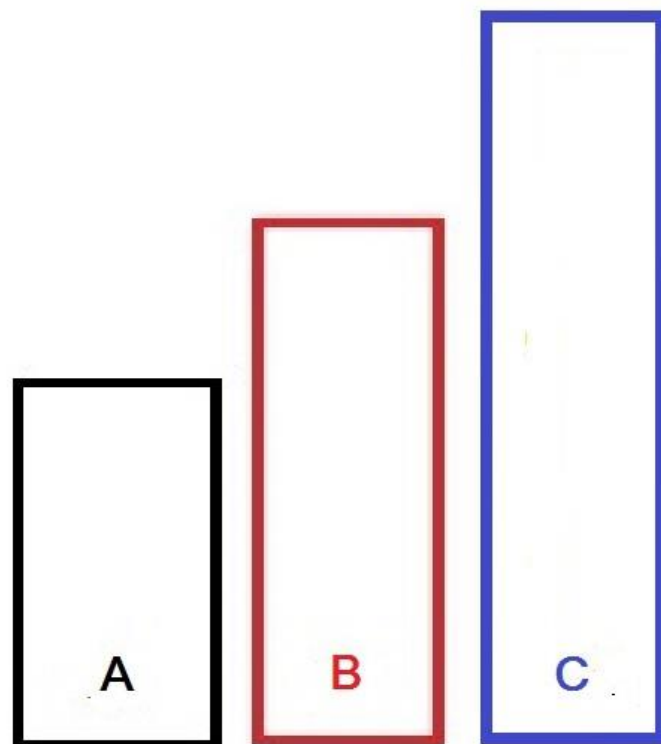

There are two methods to solve this, one could draw the sizes above to scale and then measure them. Or one can simply work out the mathematics. The answer of course, B is 40 per cent of C and A is half of the 40per cent which is therefore 20 per cent of C. (The diagram does not accurately represent these figures)

This diagram takes a vertical perspective but this does not have to always be the case. The diagrams can be drawn horizontally if it makes the subject matter easier to apprehend.

P is later than S and Q is later than P.

These forms are useful images for comparing relationships between lengths. These could be temporal, of distance or even a pecking order. One does not necessarily have to use the letters S, P and Q, one can use whatever symbols one chooses. For instance, Sarah arrived before Peter and Peter arrived before Quinton therefore:-

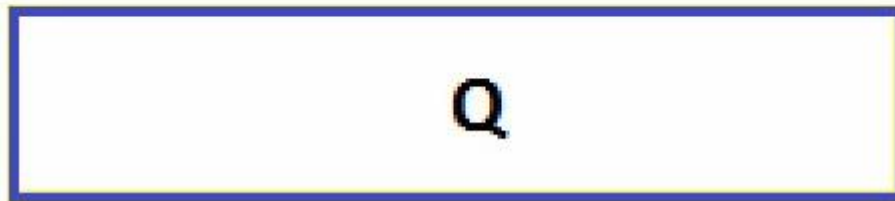

One could write in the actual names one is referring to. Once again these diagrams can be precisely drawn to scale to enable easier calculation. Be careful though with some invalid reasoning:-

High Wycombe is six miles from Marlow
Beaconsfield is eight miles from High Wycombe
Therefore Marlow is fourteen miles from Beaconsfield.

The reason why this is invalid is because High Wycombe is north of Marlow but Beaconsfield is east of Wycombe. Therefore the distance between Marlow and Beaconsfield is less. To improve this reasoning one might say:-

High Wycombe is six miles *north* from Marlow.
Beaconsfield is eight miles *north* from High Wycombe.
Therefore Marlow is fourteen miles from Beaconsfield.

This sorite is valid but the conclusion is false because the second premise is false.

Testing Sorites

Consider this:-

All advertising makes inaccurate claims and all inaccurate claims cause confusion. Whenever there is confusion and arguments people fall out. Therefore advertising can cause people to fall out with each other. The first premise states that *all advertising makes inaccurate claims*. One, therefore, draws the *advertising* box within the *inaccurate claims* box. Remember, one is not arguing that all inaccurate claims come exclusively from advertising. *All inaccurate claims cause confusion* is the second premise, therefore, the box for confusion encapsulates the box for *inaccurate claims*. Further, the *falling out* box encapsulates the *confusion* box. (Last premise)

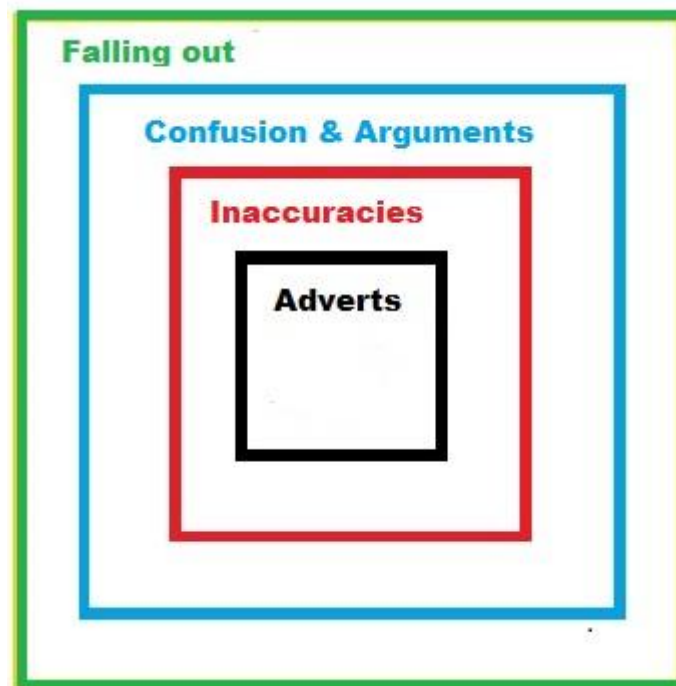

One can see from the diagram that the *falling out* box encapsulates all the other boxes including the *advertising* box, therefore advertising can cause falling out. The argument is valid.

Testing Sorites 2

Consider this problem:-

In a class there are three female students and two male students of different heights, Peter and Simon. The absent minded doctor measured all their heights but then lost the results. Fortunately he did make some notes. Is his conclusion therefore that Simon was the shortest of the five be correct? This is what he had written:-

Christine is the next shortest person to Mary, who is taller than Peter. Peter however is not the shortest male. Janice is mid-height of the five but shorter than Christine. Therefore, Simon must be the shortest of the five.

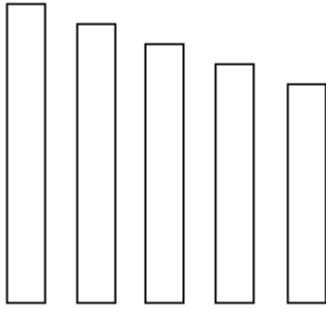

To unravel this problem, begin by recording the five names: Peter, Simon, Christine, Mary and Janice. Then draw a diagram to represent all five. Columns ascending in height help to visualise the problem.

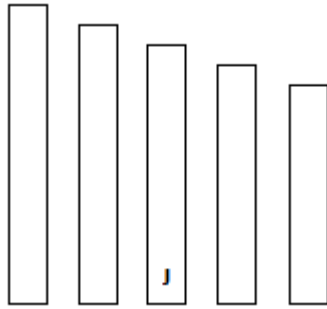

There is one firm piece of information to be identified and recorded on the diagram – Janice is mid-height. Therefore a benchmark can be illustrated with the symbol J.

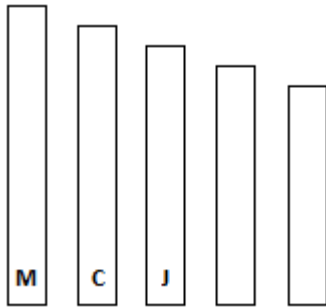

One can see from the information that Janice is shorter than Christine and Christine is shorter than Mary. The two columns to the left must, therefore, be occupied by Christine and Mary with Mary now identified as the tallest of all. This leaves two columns unoccupied.

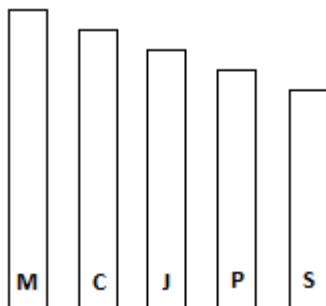

It is stated that Peter is not the shortest male, therefore, Peter must occupy the second column, leaving Simon with only one column to occupy, the shortest. The conclusion was therefore, a valid deduction.

Conditionals

Conditionals contain hypothetical statements within a syllogistic argument and usually these employ the *if* and *then* words. There is an assumption or caution over the truth value of the statement involved. Rather than say *when my dog barks the noise wakes up the neighbours*, one would say *if my dog barks then the noise will wake up the neighbours*. Another example, rather than, *copper is a good conductor of electricity then it should be used in cables*, a conditional rendering would be, *if copper is a good conductor then it should be used in cables*. These types of arguments are important for science, particularly for fundamental work in computing and artificial intelligence. They are also common in politics, *If you vote for my party you will then see the benefits*.

Valid forms of reasoning

Modus Ponens: 'If p is true, then q is true. p is true. Therefore, q is true.'

Modus Tollens: 'If p is true, then q is true. q is not true. Therefore, p is not true.'

Invalid forms of reasoning

Affirming the Consequent: 'If p is true, then q is true. q is true. Therefore, p is true.'

Denying the Antecedent: 'If p is true, then q is true. p is not true. Therefore, q is not true.'

Modus ponens

Modus ponens is Latin for 'proposing mode' and this dates back to the Stoics of ancient Greece. The standard form in traditional logic is: *if p is true, q is true; but p is true; therefore, q is true*.

For example:

If the door is left open the dog will run into the street.

The door has been left open.

Therefore the dog will run into the street.

Notice that *then* is not always expressed but the implication is nevertheless remaining. For instance, if one event occurs then another particular event will follow. There is a causal chain here. Not all *if – then* statements are casual, take this example: *if the weather reader predicts rain then you can be fairly sure nowadays that will be so*,

take an umbrella with you. The weather reader is of course not causing it to rain but is predicting events and giving advice.

Modus ponens is written in this form:-

if p then q
p
Therefore q

In other words, whenever *p* is true then *q* must also be true. The second premise *p* affirms the first premise. Traditionally this is called *affirming the antecedent*. The basic form of this syllogism is very simple but this can become more complex. For example:

if p then q
if not p then r
Therefore q or r

In normal usage:

If you eat your porridge you will grow to be tall and strong.
If you do not eat your porridge you will remain small and weak.
Therefore, either you will grow to be tall and strong or you will remain small and weak.

This follows what is known as the *law of the excluded middle*. "Either *p* or not *p*".

Modus tollens

Modus tollens is Latin for *mood that denies* and as the name suggests takes this form:-

if p then q
not -q
Therefore not - p

Without symbols: *If the first, then the second: but not the second: therefore not the first.*

As an example:-

If it rains then the ground will be wet.
The ground is not wet.
Therefore it did not rain.

This argument is valid; as the ground is not wet it could not have rained. Now consider this argument:-

If it rains then the ground will be wet.
The ground is wet.

Therefore it did rain.

Is this a valid argument? At first inspection this argument looks valid but actually it is invalid. Although the ground is wet there is nothing in the premises to say that the cause was the rain, it could have been a leaky pipe or someone with a hose, as examples. To ensure validity the first premise would have to be rewritten along these lines:-

If it rains, and only if it rains, the ground will be wet.

The addition of *only if it rains*, excludes other possibilities such as the leaky pipe as causing the ground to be wet. Take another example, as this fallacy is often committed and it is difficult sometimes to see why this is so.

If you pass your driving test your rich uncle will buy you a car.
The uncle did buy you a car.
Therefore you did pass your driving test.

This looks valid but actually is invalid. To become valid one would require the premise reformed something like this: If you pass your driving test, and only if you pass your driving test will your rich uncle buy you a car. It is the inclusion of *if and only if* that matters, an important recognition in logical thinking.

Let's consider another common fallacy, take this example-

If it rains then the ground will be wet.
It did not rain.
Therefore the ground will not be wet.

This is invalid because ground could be wet from other causes other than rain. This is fairly easy to see as a fallacy but take another example.

If you pass your driving test your rich uncle will buy you a car.
You did not pass your driving test.
Therefore your rich uncle will not buy you a car.

This type of argument is often perceived as valid but in fact is invalid. Your uncle was committed to buying you a car if you passed the test but there is nothing in the premises to prevent him buying you a car if you failed the test. It does not state that the uncle will buy you a car *only if* you pass your test.

How does one check the validity of these *modus ponens* and *modus tollens* arguments with diagrams?

If p then q

This takes the same form as the universal positive proposition form illustrated earlier. If there is p then there is q . Notice however that it does not follow that if there is q then there is p . The q box or class could contain other things. If, however there is no q then it follows there is no p either. (*Modus tollens*)

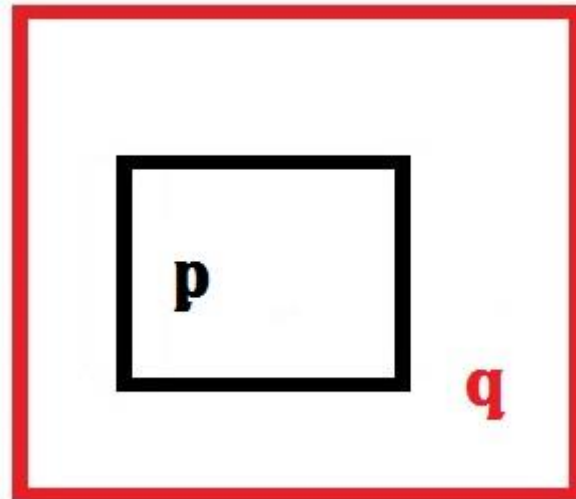

If p then not q

This takes the same form as the universal negative proposition form illustrated earlier. If there is p then there will not be q . The two boxes are drawn independent of each other:-

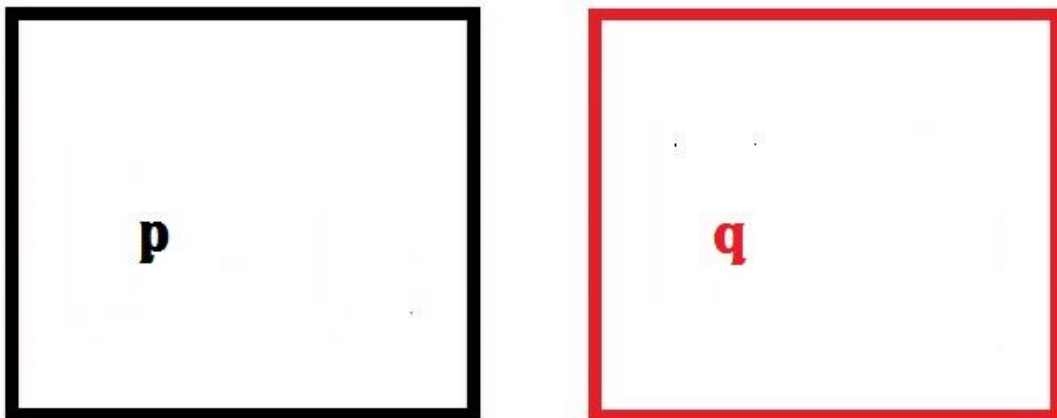

Hypothetical Syllogisms

These take the form,
If p then q ; if q then r , therefore if p then r .
The representation is as this:-

Stage 1

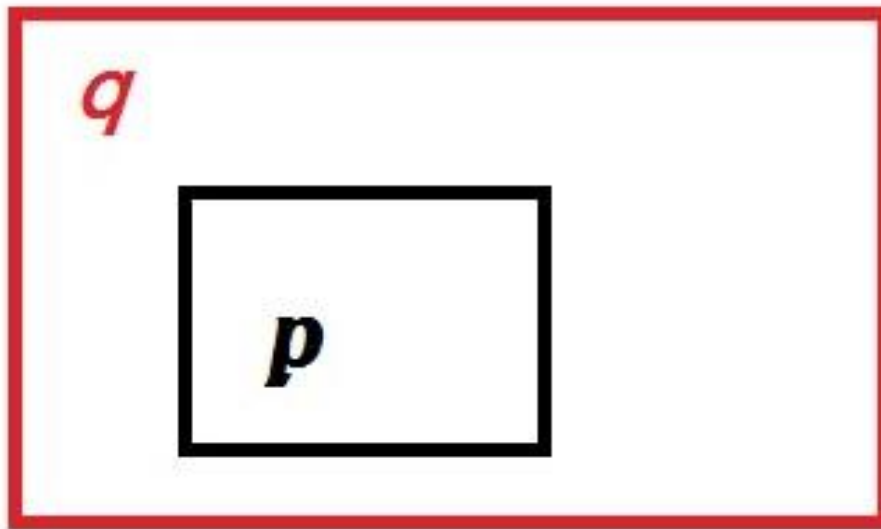

As an example, if there are any garden peas they are in the cupboard.
If there is such a cupboard it is in the kitchen.

Stage 2

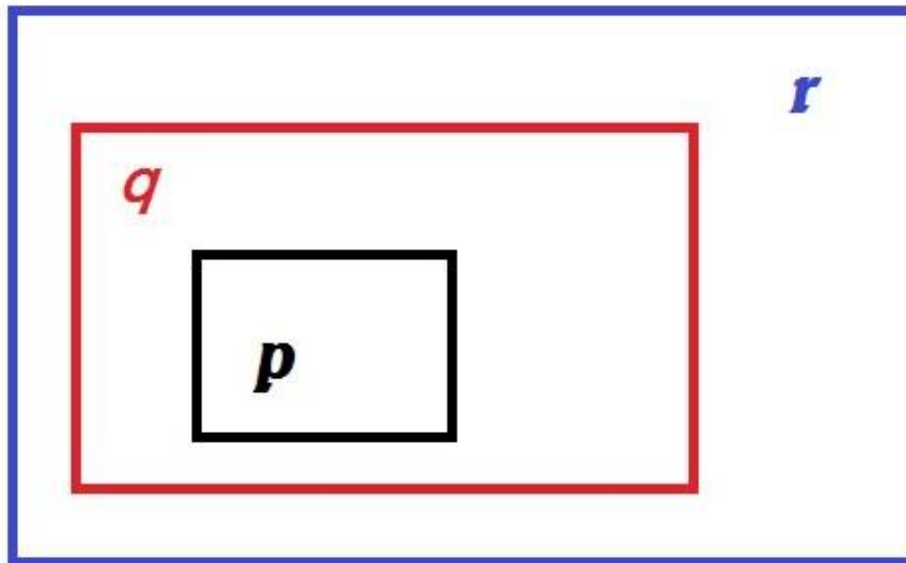

The conclusion is therefore if p then r . Or in words if there are peas they are in the kitchen. One might notice that this hypothetical syllogism follows the same diagrammatic form as the sorite *all s are p and all p are q therefore all s are q*.

Disjunctive Syllogism

These take the form, *either p or q, not p therefore q.*

Either the peas are in the cupboard or they are on the shelf.

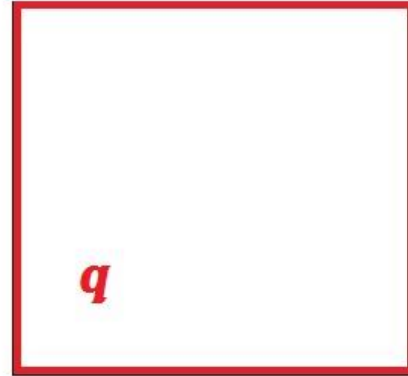
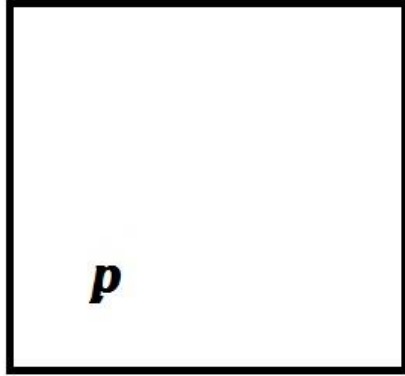

The peas are not in the cupboard (**p**). Therefore, the peas are on the shelf (**q**).



Constructive Dilemma

This takes the form, *if p then q ; and if r then s ; but either p or r ; therefore, either q or s .*

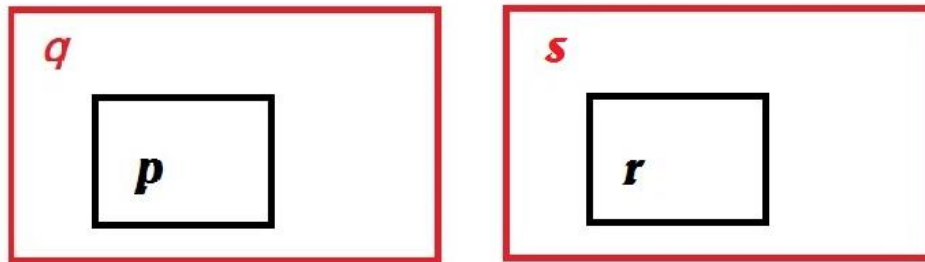

One can clearly see if it is p then only q must be entailed but if it is r then only s is entailed, therefore the conclusion is either q or s .

Destructive Dilemma

This takes the form, *if p then q ; and if r then s ; but either not q or not s ; therefore, either not p or not r .*

This takes the same diagrammatic form as above. If one removes either the q box then the p box automatically goes also or either the s box is removed then the r box is removed also.

Testing

If it rains then the ground will be wet.

It did not rain.

Therefore the ground will not be wet.

How does one test the validity of the syllogism above?

First draw a box and label it 'rain' then place this box inside a box labelled for wet ground. The implication is that every time it might rain the ground will become wet. The statement is not saying that every time the ground is wet it has rained. The box or class of '*things that made the ground wet*' will include many different causes.



The next statement says '*it did not rain*'. One therefore draws a box entitled 'no rain' and this box must be placed away from the box entitled 'rain'.

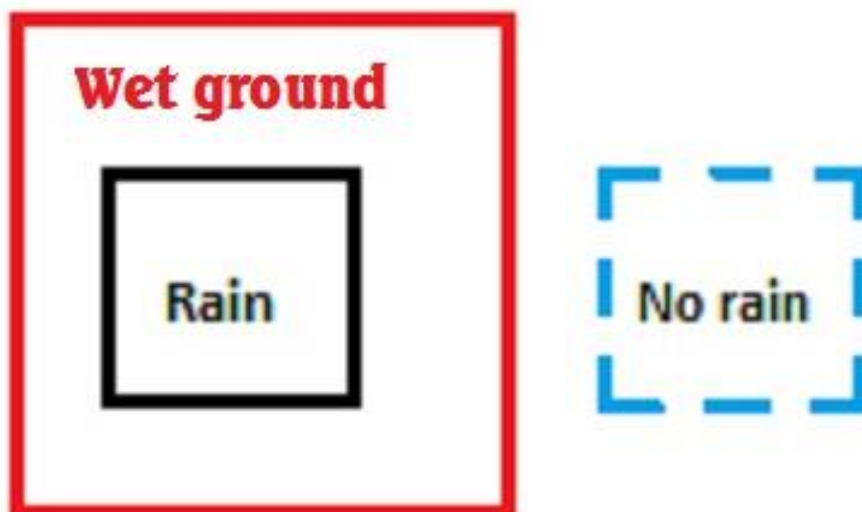

However the 'no rain' box could also be drawn as below:-

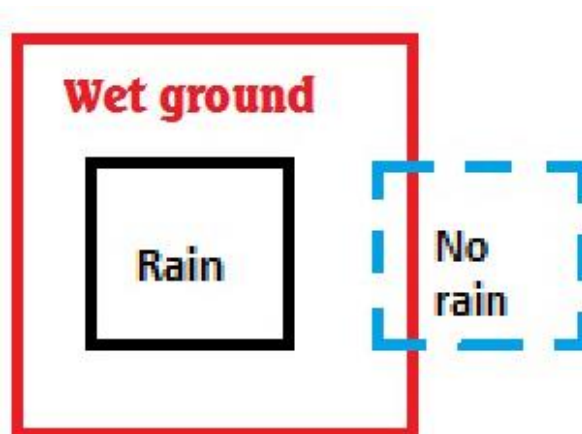

As one can see the 'no rain' box could be drawn in two different positions, as indicated by the broken blue lined boxes. One cannot conclude that there will necessarily be no wet ground. The argument is inconclusive, and therefore invalid. One only needs to show that there is more than one possible conclusion to demonstrate a fallacy. (An invalid argument) It is not always necessary to draw the third box, it is done here for easier illustration. One could simply employ the use of an x to indicate where the properties of the box lay.

Another test

If you drive too fast the car engine will over heat.
The engine has over heated.
Therefore you drove too fast.

The *driving too fast* box (p) is drawn within the *over heat engine* box (q). The second premise states that the engine did over heat.

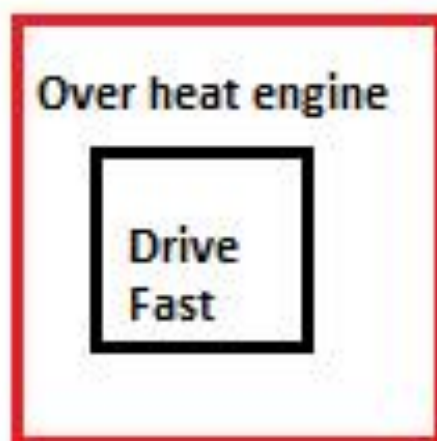

This can be represented as an 'x'. The next diagram demonstrates the possible places for the placement of the 'x'. Notice below that the x can be placed either within or outside the *drive fast* box without contradicting the second premise. As there are two possible outcomes the argument is again inconclusive and therefore invalid. The engine may have over heated from too little water or extremely hot external temperature.

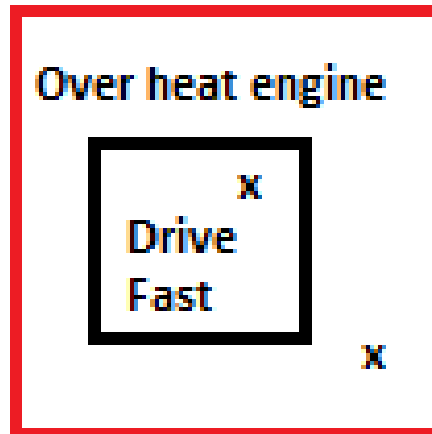

These types of fallacies can occur in science, consider this argument from biology:-

If there is natural selection then life will evolve. Life has evolved therefore natural selection was the cause.

Is this a valid argument? Actually this is invalid because life could have evolved by other means. Charles Darwin recognised that there were causes other than natural selection for the evolution of life, he just thought natural selection was the main cause. For this argument to be valid the first would need to be re-written as *If, and only if, there is natural selection then life will evolve.*

Testing negatives

If it does not rain the plants will not survive.

The plants did survive.

Therefore it rained.

When negatives are involved things become more difficult to follow and to draw the appropriate diagram. To make things easier one can learn and employ what is known as a contrapositive. This means that we can alter a statement without changing its meaning, the two statements are equivalent. Take, *if it does not rain the plants will not survive* and convert this to *if not p then not q*. To obtain the contrapositive one removes both the *nots* and switches the *p* with the *q*. The result is *if q then p*. One can now convert our original statement to its contrapositive – *If the plants survive then it has rained*. This contrapositive form can now be placed in the argument.

If the plants survive then it has rained.

The plants did survive.

Therefore it rained.

To represent this –

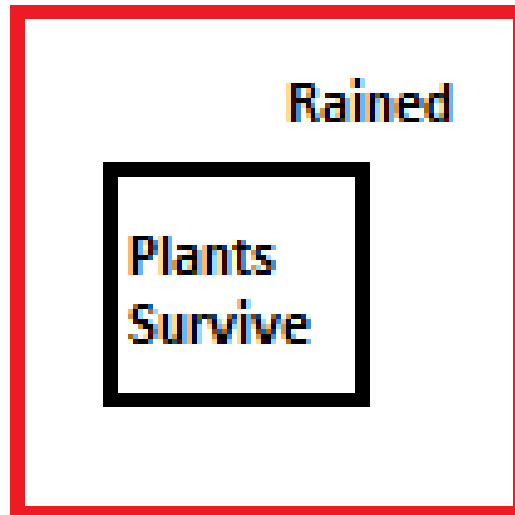

This diagram illustrates that the *if plants survive* box is within the *rained* box showing the argument to be valid.

How to spot invalid arguments

There must be three and only three unambiguous terms in the syllogism, the subject, the predicate and the middle term. Often these terms appear twice but one has to be careful for sometimes they are unwritten but implied. One example is the enthymeme. It has already been mentioned that the terms of a categorical syllogism must be in the correct positions and that the middle terms of the premises should not constitute the content of a conclusion. The subject and predicate of a conclusion must also be present or at least implied in the premises. Another thing to check for, is that if one or more of the premises, *no ducks are pink / some ducks do not fly*, are negative then the conclusion should also be negative. Again, if both premises are universal, *all ducks quack / all animals that quack*, then the conclusion must be universal too. Similarly, if there is one or more particular premise, *some birds eat only nuts*, then the conclusion must also be particular, not universal. If one notices that both premises are negative, *some ducks are not for sale / no ducks like a drought*, then the argument is invalid, even if the conclusion and premises are all true. There are other things that render an argument invalid, some of which will be illustrated here.

Ambiguity.

It is important that premises are clearly written without being open to different interpretation. Take this example: –

God is love
Love is blind
Therefore God is blind

At face value this looks to be a valid syllogism but it carries the charge of invalidity because the term ‘love’ is ambiguous. In the first premise the meaning could be that God is an example of love or that love emanates from God. In the second premise the meaning could be that one is infatuated and the biological pheromones are interfering with ones’ normal rationality. With so many interpretations of the word ‘love’ the argument is invalid.

Consider another example:-

Hospital maternity wards are the places where all women traditionally had their babies.
Mary had a little baby lamb.
Therefore Mary gave birth to a lamb in hospital.

Assuming Mary is a woman does it not follow validly that she gave birth to a lamb in a hospital maternity ward? After all an argument can hold absurd premises but still be valid. Well, not in this instance, the problem is the ambiguous nature of the word

'had'. In the first premise 'had' means women *give birth* and in the second premise 'had' means *to possess*.

Metaphor

Metaphors are often used in literature to provide clarity or emphasise a point by using a completely different and unrelated concept. Metaphors are not analogies or similes. In science metaphors can be used to illustrate phenomena that are normally difficult to explain in non-mathematical terms. Logicians try to avoid their use whenever possible for they cause confusion and can lead to fallacies. In the 1970s Richard Dawkins wrote the 'Selfish Gene', which was intended to explain the importance of genes in evolution. His choice of the metaphor 'selfish,' however caused much debate and confusion amongst biologists and philosophers that became quite acrimonious. Fortunately, the debate has subsided as biologists began to recognise other important factors of evolution other than genes, such as RNA, proteins and the influence of epigenetics. Let's take some examples:–

All the world's a stage, and all the men and women merely players.
My Aunt, who plays hockey and lives over a thousand miles away in Canada.
She must also live on a stage.

All things made of gold are good investments.
Shelly has a heart of gold.
Shelly, therefore has a good investment.

Shakespeare's '*all the world's a stage*' and '*Shelly has a heart of gold*' are the obvious metaphors that make both arguments above invalid. The difficulty with spotting metaphors is that one must know they are metaphors beforehand which is easier with well-known ones but difficult with novel ones.

Contradiction, Oxymoron and the Contrary

A proposition that contains contradiction in logic is different to a proposition or propositions that are contrary. So what is the difference? Contrary propositions or statements are where two or more pieces of information given cannot both be true but both could be false. For instance, one person may say, *the pigeons ate all the strawberries* but another person may say contrarily, *no, the blackbirds ate all the strawberries*. Both birds could not have eaten all the strawberries, one of the birds could have but it is also possible that neither did and in fact it was another type of bird.

With a contradiction, if one piece of information is true then the negative must be false and vice versa. Both, cannot be true or both false. For instance, if someone says, *the blackbirds ate the strawberries* and another person says, *no, it was not the blackbirds that ate the strawberries*, this is a contradiction. Either the blackbirds ate the strawberries or the blackbirds did not eat the strawberries. It is easy to confuse the contrary with a contradiction, consider this proposition taken from a logic internet site- *All lemons are yellow and Not all lemons are yellow*. According to the authors this is an example of a contraction but can you see the problem here? The negative of

All lemons are yellow is *No lemons are yellow*. Both are universal statements but if one says *not all lemons are yellow* then this leaves the possibility that some lemons are yellow and therefore is contrary. *All lemons* and *some lemons* could both be false because it is possible there are no lemons.

With an oxymoron the contradiction could be contained within a statement. Some examples:–

Appear invisible.
Lead from the rear.
Controlled chaos.
Beauty in ugliness.
Growing small.
Known secret.

An example of a syllogism that contains an oxymoron:–

The police are arresting only those vendors who are selling cheap copies of the genuine brand named handbags.
Jim is a street vendor who only sells handbags that are genuine fakes.
Jim will not therefore be arrested by the police should they find him.

It is the use of the term ‘genuine fake’ that is an oxymoron and therefore, it is an invalid argument.

Tautology

A tautology is always held to be true but this is where information is repeated unnecessarily in a statement or an argument. The classic example of this is ‘I believe in fate because everything that could happen will happen and everything that did happen was meant to happen.’ Sometimes the tautologies are more subtle, consider this – *All things being equal, an investment which pays a higher interest rate will provide a better return than an investment which pays a lower interest rate.* Although true, this statement would only be of value if one had no understanding of the difference between higher and lower. Consider this argument:–

I predicted that either it will snow or it will not.
It did not snow therefore my prediction was correct.

Once again the conclusion is true but then it could not be false. If it snowed then the prediction would also have been correct.

Exercise 3

Are the following valid or invalid:-

1. All M are P. All S are M. Therefore, All S are P.
2. Some M are not P. All M are S. Therefore, Some S are not P.
3. No P are M. All S are M. Therefore, No S are P.
4. All P are M. No S are M. Therefore, Some S are P.
5. Some M are S. Some S are P. Therefore Some M are P.
6. No P are M. No M are S. Therefore no P are S.
7. Some P are not S. Some S are not M. Therefore Some P are not M.
8. Most of P are S. Most of P are M. Therefore some S are M.
9. Most of P are S. Most of S are M. Therefore some P are M.
10. Most of P are S. Some of S are M. Therefore some P are M.
11. Most of P are not S. Most of P are M. Therefore some S are M.
12. Some P are not M. Most P are S. Most S are G. Therefore some M are G
13. In a recent birthday event 5 friends participated in a Go-Kart race, averaging speeds of 40, 30, 20, 10 and 5 mph. Terry finished directly behind Jennifer and Mike averaged exactly three times the speed of another contestant. Amy was faster than Terry but did not finish first. One can conclude therefore that Sally was the winner.
14. If there is a dog in the room there will be a cat also in the room. There is no cat in the room therefore there is no dog in the room.

Answers to exercises

Exercise 1

A11-1 and 1A1-4

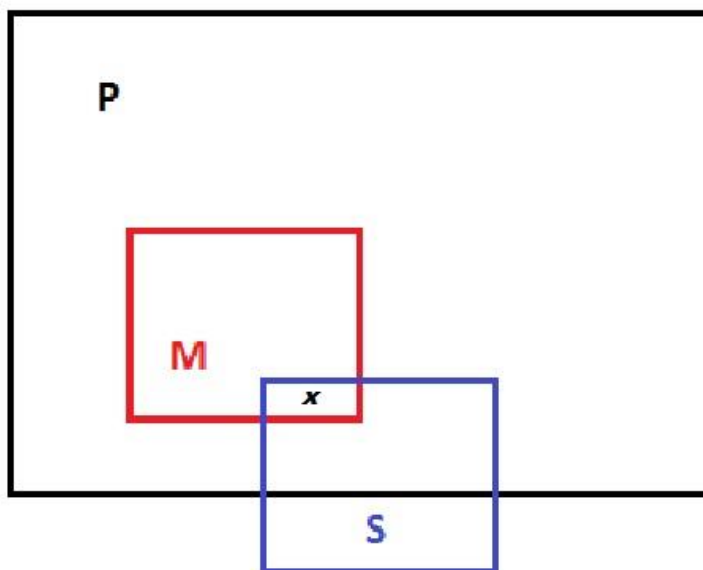

A11-1

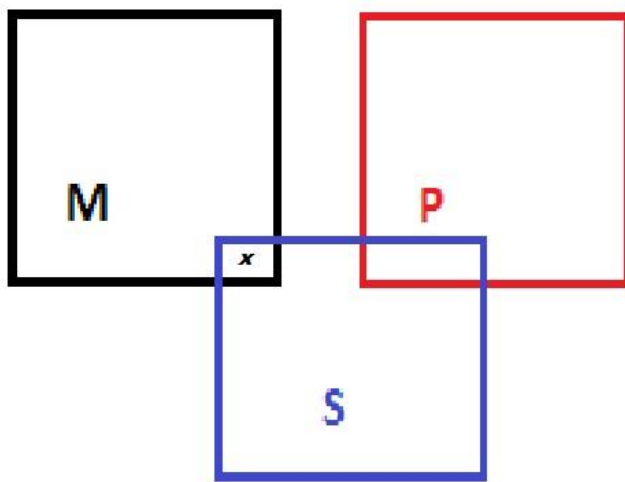

Exercise 2

The following forms of conditional syllogism differ in conclusion to those analysed by modern Euler diagrams.

EAO-1

AAI-1

EAO-2

AEO-2

AEO-4

The remaining four conditionals concur.

Exercise 3

1. *All M are P. All S are M. Therefore, all S are P. Valid*

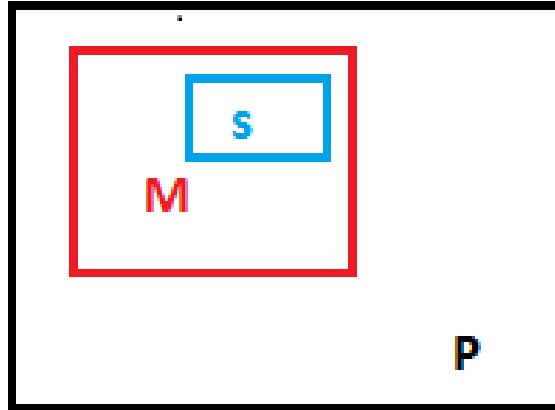

2. *Some M are not P. All M are S. Therefore, some S are not P. Valid*

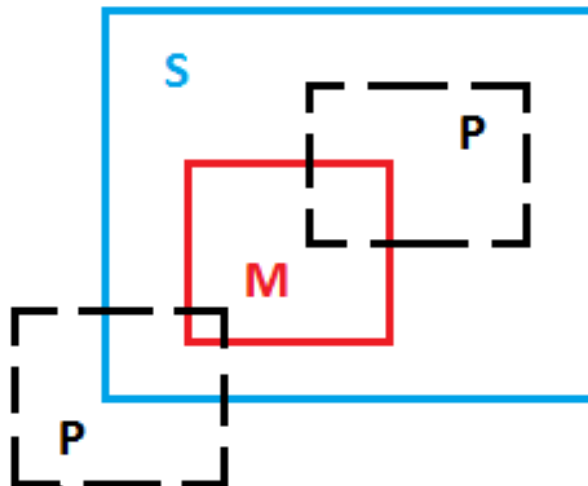

3. *No P are M. All S are M. Therefore, no S are P. Valid*

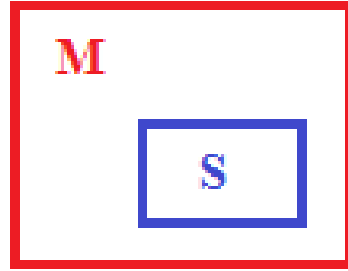
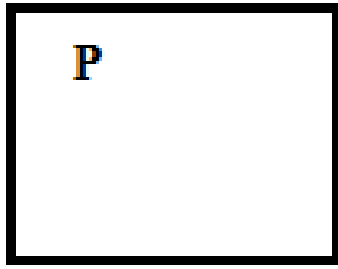

4. *All P are M. No S are M. Therefore, some S are P. Invalid*

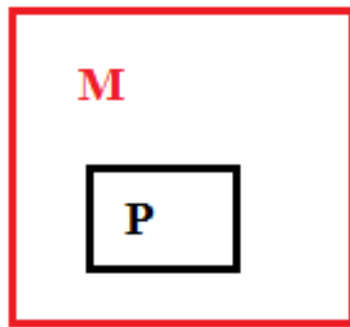

5. *Some M are S. Some S are P. Therefore some M are P, Invalid*

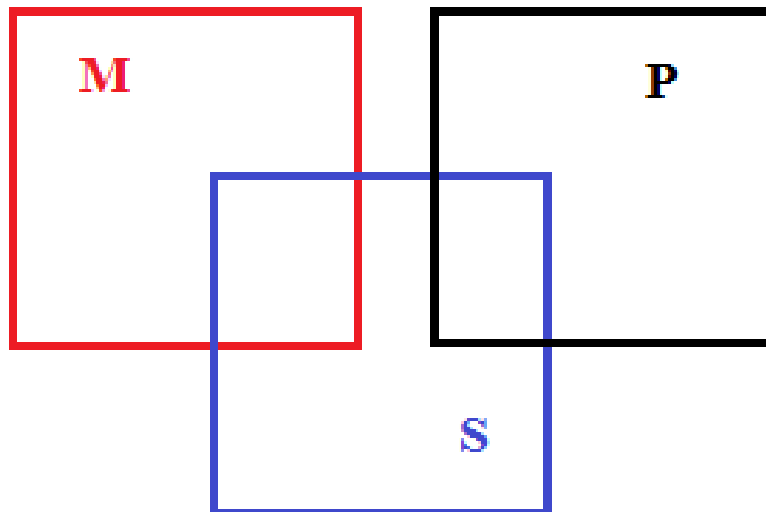

6. *No P are M. No M are S. Therefore no P are S. Invalid*

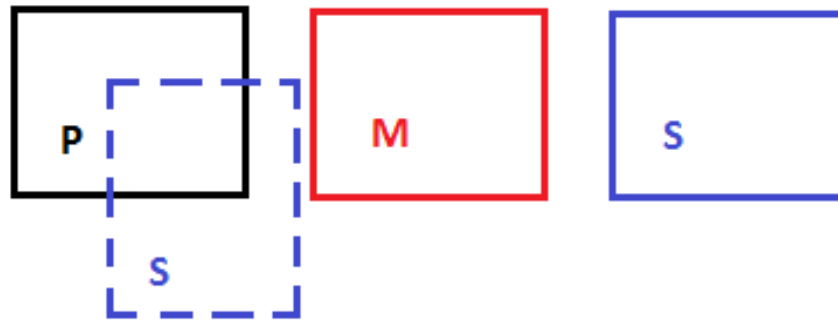

7. *Some P are not S. Some S are not M. Therefore, some P are not M. Invalid*

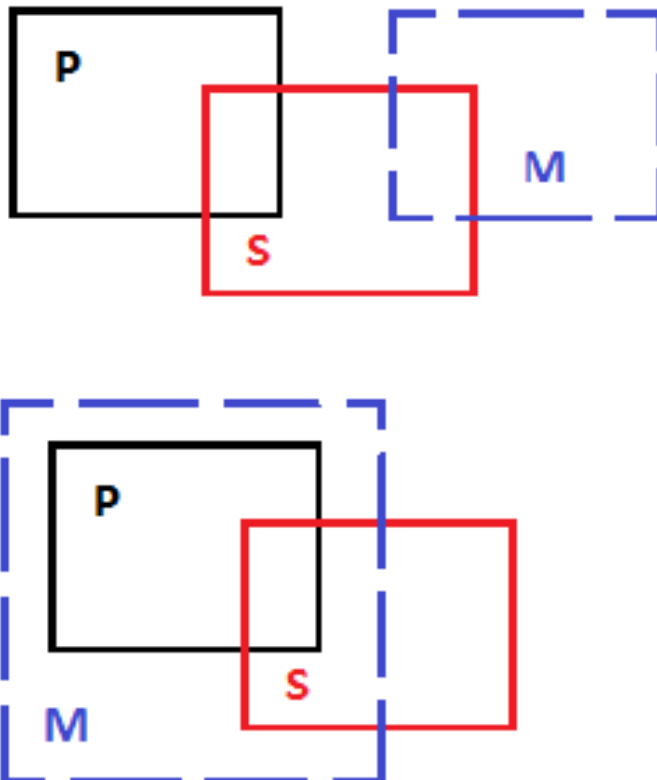

8. *Most of P are S. Most of P are M. Therefore, some S are M. Valid*

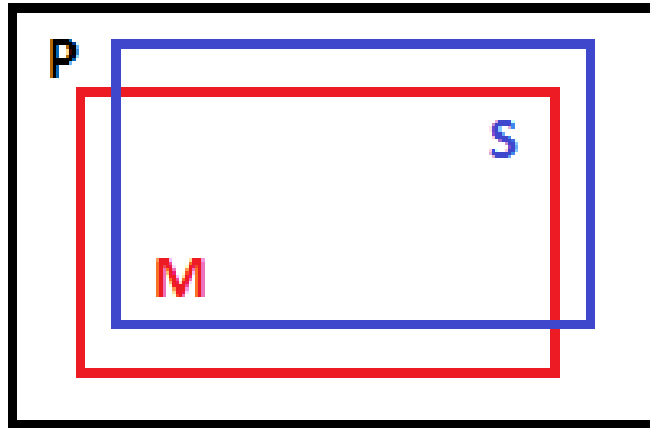

9. *Most of P are S. Most of S are M. Therefore, some P are M. Valid*

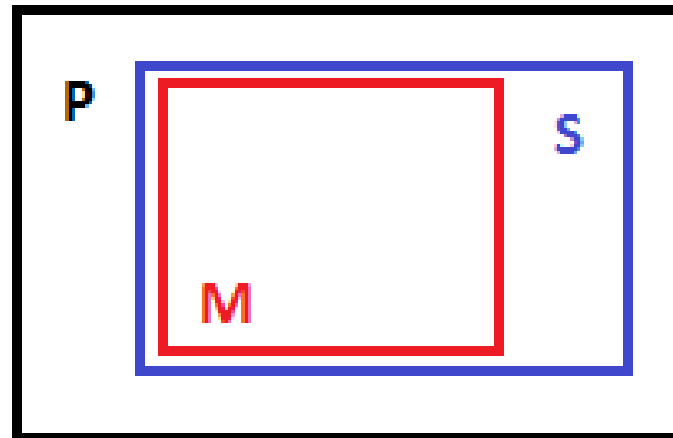

10. *Most of P are S. Some of S are M. Therefore, some P are M. Valid*

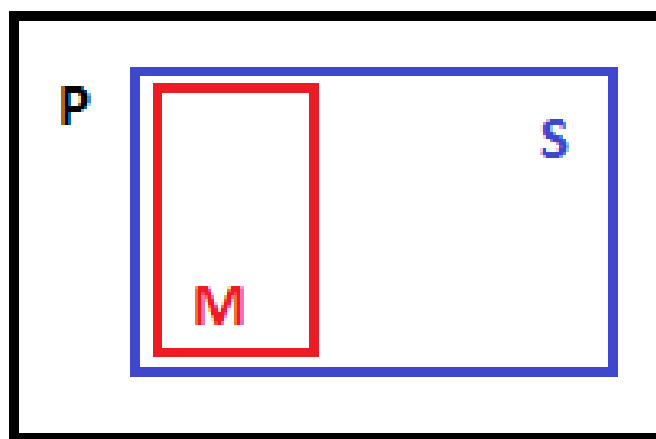

11. Most of P are not S. Most of P are M. Therefore, some S are M. Invalid

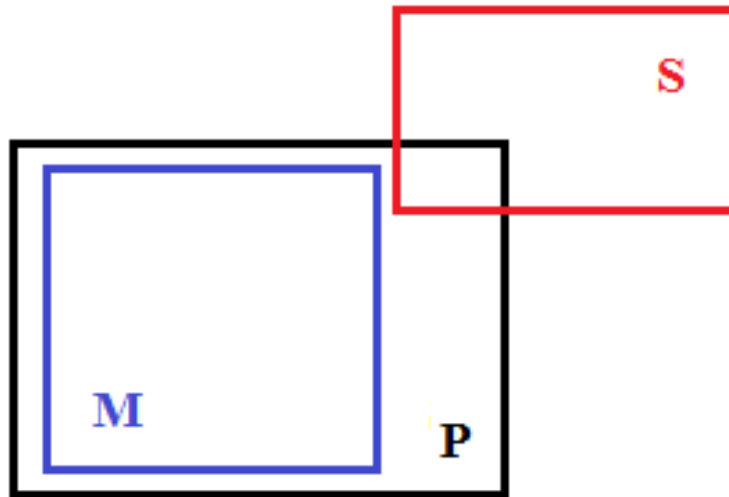

12. Some P are not M. Most P are S. Most S are G. Therefore, some M are G. Invalid

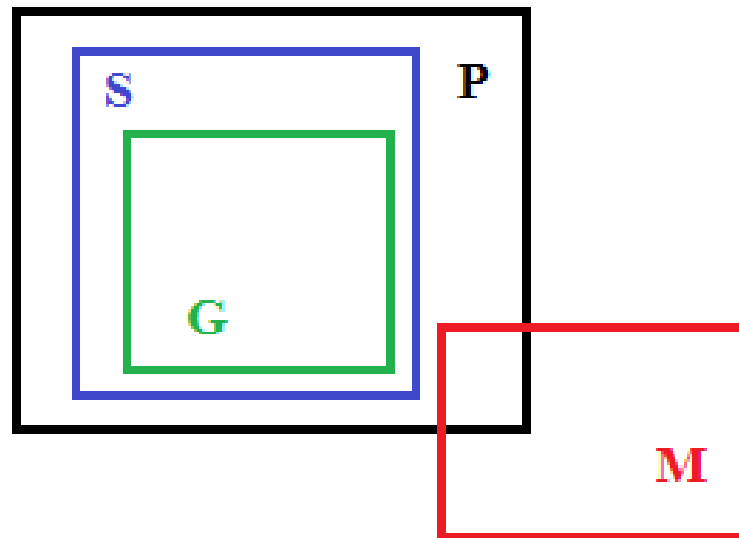

13. *Valid, Sally was the fastest.*

Sally	40mph
Mike	30mph
Amy	20 mph
Jenifer	10 mph
Terry	5 mph

15. *If there is a dog in the room there will be a cat also in the room. There is no cat in the room therefore there is no dog in the room. Valid, if the cat is not in the room then the dog is not in the room.*

