



Hidden Concepts in the History and Philosophy of Origins-of-Life Studies: a Workshop Report

Carlos Mariscal, et al. [full author details at the end of the article]

Received: 21 February 2019 / Accepted: 12 June 2019 / Published online: 09 August 2019
© Springer Nature B.V. 2019

Abstract

In this review, we describe some of the central philosophical issues facing origins-of-life research and provide a targeted history of the developments that have led to the multidisciplinary field of origins-of-life studies. We outline these issues and developments to guide researchers and students from all fields. With respect to philosophy, we provide brief summaries of debates with respect to (1) *definitions (or theories) of life*, what life is and how research should be conducted in the absence of an accepted theory of life, (2) *the distinctions between synthetic, historical, and universal projects* in origins-of-life studies, *issues with strategies for inferring the origins of life*, such as (3) *the nature of the first living entities* (the “bottom up” approach) and (4) how to infer *the nature of the last universal common ancestor* (the “top down” approach), and (5) *the status of origins of life as a science*. Each of these debates influences the others. Although there are clusters of researchers that agree on some answers to these issues, each of these debates is still open. With respect to history, we outline several independent paths that have led to some of the approaches now prevalent in origins-of-life studies. These include one path from early views of life through the scientific revolutions brought about by Linnaeus (von Linn.), Wöhler, Miller, and others. In this approach, new theories, tools, and evidence guide new thoughts about the nature of life and its origin. We also describe another family of paths motivated by a “circularity” approach to life, which is guided by such thinkers as Maturana & Varela, Gánti, Rosen, and others. These views echo ideas developed by Kant and Aristotle, though they do so using modern science in ways that produce exciting avenues of investigation. By exploring the history of these ideas, we can see how many of the issues that currently interest us have been guided by the contexts in which the ideas were developed. The disciplinary backgrounds of each of these scholars has influenced the questions they sought to answer, the experiments they envisioned, and the kinds of data they collected. We conclude by encouraging scientists and scholars in the humanities and social sciences to explore ways in which they can interact to provide a deeper understanding of the conceptual assumptions, structure, and history of origins-of-life research. This may be useful to help frame future research agendas and bring awareness to the multifaceted issues facing this challenging scientific question.

Keywords Theories of life · LUCA · Multidisciplinary science · Prebiotic evolution · Self-organization · Artificial life · Epistemology

Introduction

The origin of life is among the most fundamental open questions in science. It can be difficult for even practicing scientists to agree on the object of inquiry, standards of evidence, or even their own disagreements. To an extent, these problems are common to all sciences, but they face a new challenge in cutting-edge, multidisciplinary and empirically under-constrained fields like the origins of life. Scientists investigating the origins of life generally acknowledge the depth and complexity associated with the topic, which often requires input from many different scientific disciplines. Less recognized is the historical, sociological, and philosophical context surrounding the ways researchers in different disciplines work together to investigate this problem.

There is ample scope for historical and philosophical work on origins-of-life studies to explore broad questions such as: (1) whether and to what extent origins-of-life concepts, hypotheses, and principles fit together logically, methodologically, theoretically, and empirically; (2) how and to what extent diverse empirical methods can provide evidence to support or refute claims about origins, including traditional questions of explanation and confirmation; (3) what are the scope and limits of origins-of-life studies in relation to other sciences, including traditional questions about reduction and emergence (Griesemer 2008).

In this paper, we discuss broadly some of the ways in which philosophers, historians, and other scholars in the natural and social sciences and humanities can inform and impact research about the origins of life. We do not intend this to be an exhaustive survey of the history of the field or a history of the field per se, rather it is intended as a survey of the broader concepts which underpin modern research. Readers seeking critical discussions of current technical scientific debates or more comprehensive historical treatments of various more focused issues are encouraged to use the references included here as a connection to this literature. We begin this survey by considering the conceptual issues in origins-of-life research, in which philosophers may play a fruitful role. We then consider historical and societal impacts on current origins-of-life research, and trace the historical development of two distinct threads of modern inquiry on the topic. Finally, we conclude with a call for breaking down disciplinary walls that are demonstrably harmful to scientific progress. We hope this will provide a roadmap for origins-of-life scientists interested in the broader historical and philosophical basis of their work, as well as scholars in the humanities interested in exploring this exciting area.

Philosophical Considerations with Respect to the Origins of Life

In this section, we discuss some key philosophical issues in the origins of life. Out of dozens of philosophical and epistemological issues, five are highlighted: (1) *the definition (or theory) of life*, (2) *what origins-of-life models explain*, (3) *issues in inferring the origins of life from simple starting materials (the “bottom-up” approach)*, (4) *issues in inferring the subsequent steps in life given current descendants (the “top-down” approach)*, and (5) *the current status of the study of the origins of life as a science*. Compared to workers in more traditional areas of biology, scientists in the origins-of-life community tend to be more sensitive to the philosophical issues in their field, so some of these areas may be familiar to practicing origins scientists, though all remain contentious.

The Nature of Life, and the Distinction between Living and Non-Living Phenomena

How a non-living world can give rise to a living world is a deep question. Not only are there significant differences between living and non-living objects, but the emergence of life and subsequent biological and geological evolution may have erased or over-printed all evidence of any or many intermediate steps between purely abiotic processes and the simplest forms of life. Organizing these problems into a unified and successful research program requires a comprehension of the type of “biological” systems whose origins we are trying to understand (Ruiz-Mirazo et al. 2004; Bich and Green 2017). Many researchers explicitly assume that studying the origins of life requires a definition of life, a proposal which sounds straightforward, but may be problematic (Cleland and Chyba 2007; Cleland 2020). For any definition of life, clever philosophers can pose apparent exceptions. It is possible that there is no defensible basis for assuming a clear, widely accepted dividing line between life and non-life. If this is true, there are several potential alternatives.

1. **Life’s essence.** One path may be to capture the aspects of life that come closest to *the essence of life* (Cornish-Bowden and Cárdenas 2017).
2. **Life as consensus.** Others argue “life” means different things for the public than it does for scientists (and even among different kinds of scientists), making a *consensus more a matter of sociology than scientific discovery* (Keller 2009; Machery 2012).
3. **Life is defined by its participation in the biosphere.** Another pragmatic approach, which cuts across efforts, is to adopt a view of life from the perspective of a biosphere (Feinberg and Shapiro 1980; Smith 2018). From this point of view, rather than conceiving of organisms as living, one might better view organisms as “alive” derivatively due to being part of a living biosphere.
4. **Life will be defined when we see it again.** Some may suggest *skepticism or caution*, urging continued research in the hopes of discovering or creating an accepted second instance of life (Cleland and Chyba 2007; Cronin et al. 2006).
5. **A “theory” of life is needed, rather than a definition.** Some authors challenge the entire project of seeking a “definition” of life and instead suggest *the goal is to develop a “theory” of life* (Cleland and Chyba 2007).
6. **No definition is required.** These pragmatic approaches have been championed by researchers like Szostak (2012). This family of approaches takes the task of science as being divorced from philosophical definitions. These authors prefer general characteristics, operational definitions, or stipulative definitions over precise formal definitions.
7. **There is no such thing as life.** The most extreme accounts are provided by eliminativists, who maintain there is no objective category as “life,” though they may still accept pragmatic approaches to origins-of-life research (Descartes 1664/2010; Jabr 2013; Mariscal and Doolittle 2015).

It may be that the need for a definition of life is not as important as an understanding of the series of processes that can give rise to complexity and life-like processes (Smith and Morowitz 2016). It is also possible that an improved definition of life may emerge as a product of a more complete origins theory in the future. Despite the difficulty of a single account for something as multifarious as life, most scientists would feel such an approach too distant for the problem at hand. Philosophy in this domain serves the synthesis role, helping grasp the stages of the transition from chemistry to biology and building a fruitful conceptual

framework. Philosophers may be concerned with issues like the emergence of functional organizations, of individuality and its self-reproduction; the origin of evolution and the unfolding of biological phenomenology; the appearance of genetic information, agency and regulation; or the origin of cooperation and symbiosis, as well as their interrelationship (Moreno 2016). Complementarily, historians and social scientists can help recover the social networks and investigative and theoretical pathways on which current and future thought on the origins of life are and will be built, situating it for future scientists and the broader public (Latour 1987; Holmes 2004).

Necessity, Contingency, and Chance

Scharf et al. (2015) point out three overlapping questions relevant to the origins of life: (1) universal, (2) historical, or (3) synthetic. Each of these is the project of some origins-of-life research, although this is rarely made explicit.

“Universal” explanations focus on *necessary* steps in the origins of life. Scientists seek such steps when they wish to understand universal processes in biology or the evolution of life itself. These are risky scientific conjectures, as universal claims are true only if their opposite cannot be true. This means that truly universal explanations ought to apply to any life we discover or create. Some of the present authors are skeptical of such claims, noting the difficulty in justifying inferences from a single example of life (Cleland and Copley 2005). The specificity and rigidity of universal claims are still open questions.

The second type of explanation is “historical” and refers to the path life on Earth could have taken from its inception (B in Fig. 1). These explanations are contingent on knowledge of Earth history. To give accurate historical explanations, prospective modelers or experimenters must keep up with geological models for the early Earth, e.g., the nature of the early oceans, the temperature of the environment, the existence of free energy sources, and so forth. As such models shift, so do the problems and paradoxes origins-of-life researchers must solve. For example, there is some disagreement about whether there was any dry land available on Earth for the origins of life. A completely water-covered planet would offer support for origins models positioned in deep-sea environments (see, for example, Russell et al. 2005), and at the same time, undermine those that require intermittently dry conditions (e.g., Nelson et al. 2001; Maruyama et al. 2013; Damer and Deamer 2015). Historical explanations typically assume that there was a single origin of life on Earth, although this may simply be because this situation is currently indistinguishable from the scenario in which life originated several times. Nevertheless, in the future, it may be possible to distinguish the alternative possibilities of other original lineages having gone extinct or even having hybridized with our own lineage (Gogarten-Boekels et al. 1995, see Fig. 1, Cornish-Bowden and Cárdenas (2017).

Synthetic explanations are the least constrained of the three types. They seek to show how life could *possibly* come to be and are somewhat analogous to existence proofs in mathematics: they show that something is possible by demonstrating it. Thus, synthetic explanations include experimental demonstrations of plausible prebiotic synthesis of biomolecules, the experimental construction of protocells, and many applications of synthetic biology as well as computational demonstrations of phenomena in evolution or self-organization. Typically, the value of synthetic approaches is not in directly answering questions about the world. Their value is in showing that something is possible that might have been thought impossible (Dray 1957), or that something is simple that might have been thought difficult (or the converse), or simply in understanding a phenomenon with a concrete, proof-of-principle example.

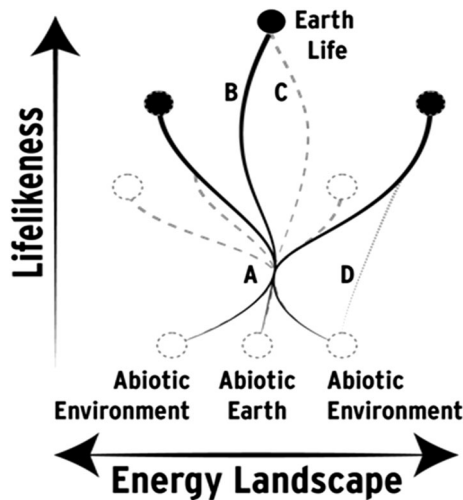

Fig. 1 An illustration of paths from lifeless environments (dashed circles) to living worlds (black circles). Black lines mark paths actually taken somewhere in the Universe, dashed lines mark possible paths. Axes are unspecified metrics of “lifelikeness” (y) and an energy landscape through which precursors to life travel (x). A) universal explanations for the origins of life: steps that scientists think must be taken in any path from a lifeless world (bottom) to a living one (top); B) historical explanations, about the path life on Earth could have taken from a lifeless Earth to LUCA; C) *synthetic explanations, which detail other possible paths life might have taken*; and D) *synthetic explanations, which challenge universal explanations and detail how life may have been created under alternative scenarios*. If there are few synthetic paths relative to universal paths, life on Earth would be highly convergent with life elsewhere, and vice versa. Adapted from Scharf et al. (2015). Exploring this possibility space is part of the difficulty of origins research

Synthetic explanations are closely associated with questions about whether alternative forms of life are possible. These include alternative chemistries (Bains 2004; Cleaves et al. 2015; Ilardo et al. 2015), alternative energy sources (Schulze-Makuch and Irwin 2006), and alternative substrates (Langton 1998). Particularly exciting is the (possibly remote) possibility of discovering extraterrestrial examples of these on nearby planets or moons. If anything is discovered, its relationship to life (see 2.1) will be a matter of intense debate, but so, too, will its relationship to the historical and universal projects in origins of life. Synthetic approaches assume that the nature and origins of life can be understood by analogy or abstraction rather than merely appealing to Life’s history on Earth. Critics point out that the material composition of a physical system is often crucial to its causal capacity to perform a given function (e.g., Di Paolo et al. 2000; Silverman and Bullock 2004).

One can gain important insights into the nature and origins of life by abstracting from the physical and chemical characteristics of life and simulating them on a computer, although downplaying the importance of the differences may presuppose an answer to the very question at issue. There is typically a trade-off between accuracy and generality. More accurate synthetic explanations, such as those from experimental evolution or synthetic biology, may add interesting details about scenarios for life as we know it (C in Fig. 1). Meanwhile, abstract functional computer models may yield broad insights about many kinds of life as it could be. Each offers distinct evidence and implicit assumptions, and both may be important scientifically. Synthetic origins-of-life explanations can serve as tests to strong claims of universal biology (D in Fig. 1, which may violate the assumption that A is universal).

Origins-of-life researchers are engaged in different research programs, which use different tools and accept different standards of evidence. Much argument could be avoided if it were acknowledged within the origins-of-life community that these research programs overlap and interact. While researchers in one camp may find alternative research programs boring, impossible, or even irresponsible, standards of evidence are sometimes informed by unstated epistemic values. A researcher valuing general explanations may be skeptical of relying on ever-changing conceptions of conditions on the early Earth, while a researcher valuing accurate explanations may worry about universal or synthetic explanations which appear ungrounded by real-world examples. The philosophical literature on the various epistemic values of science may be helpful in making sense of such fundamental differences in scientific temperament (Kuhn 1962; Beatty 1997; Douglas 2016).

The relationship between these explanatory projects and the traditional worries of contingency and necessity in the origin of life cannot be ignored. Figure 2 illustrates that the answer need not be a stark choice between deterministic necessity and random chance. Aspects of the origins of life could be necessary (A) or highly contingent (B & C). The roots of this debate go as far back as Oparin arguing for the ‘lawfulness’ of life’s origin against Eigen (Cairns-Smith 1971; Wetter 1958; O’Malley 2014), and have been later discussed by authors like de De Duve (1991) and Morowitz (1991), in connection with the continuity thesis and the problem of carrying out scientific inquiry regarding the origins of life, as reviewed by Fry (1995).

Bottom-up Issues

One approach to origins-of-life research, the ‘bottom-up’ one, begins with known or inferred features of the early Earth and modern examples of chemistry, which have been studied over very short periods of time in laboratories (Orgel 1998a, 1998b). These approaches infer the self-organization and evolution that might have led to the formation of life (Lazcano and Miller 1996). The field of prebiotic chemistry is central to bottom-up approaches. The purview of this field is to assess exactly what types of molecules could have been synthesized in the early solar

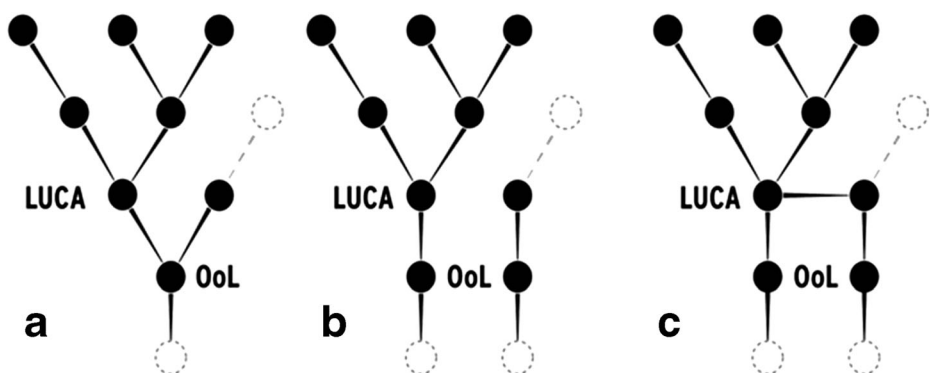

Fig. 2 Three possibilities since the origin(s) of life (OoL) that are currently indistinguishable. Solid circles represent living taxa, dashed circles and lines represent non-living or extinct taxa, solid lines connect living taxa with their ancestors. A) All life on Earth shares a Last Universal Common Ancestor (LUCA). B) Life originated multiple times, but all other lineages have either gone extinct or are yet to be discovered (Cleland and Copley 2005; Davies and Lineweaver 2005). C) Life currently contains genes or other information from a second origin (or perhaps a distant relative), from which no descendants remain or have not yet been discovered. Adapted from Powell and Mariscal (2015)

system, with the goal of trying to understand how the compounds known life is composed of could have been synthesized without the intervention of pre-existing biochemical processes. Bottom-up approaches require knowledge of the available molecules, environmental parameters, interaction rates, and so on. They also require a philosophical stance as to which events in an origin story are conceptually important enough to be considered ‘steps’ on the road to life.

Note also the possibility that starting life could require a rather different suite of molecular compounds than maintaining/evolving life. It is tacitly assumed that we should only pursue the synthesis of familiar compounds or classes of compounds (amino acids, nucleotides, sugars, fatty acids etc.). We cannot ignore the inconvenient possibility that such compounds only function as downstream products of evolutionary optimization of existing processes. It may be impossible for life to emerge in systems dominated by only those familiar biomolecules.

Among the abstract functional characteristics of familiar Earth life, the most often noted as essential are:

- (1) the capacity to maintain self-organization for an extended period against perturbations,
- (2) the capacity to reproduce and transmit to progeny adaptive characteristics,
- (3) both of those capacities and more, but which only emerge when certain systemic clusters occur.

Examples of the first include metabolic (e.g., Oparin 1924), thermodynamic (e.g., Kauffman 2000), and organizational ones (e.g., Maturana and Varela 1980; Rosen 1991; Gánti 2003). Darwinian (e.g., Dawkins 1982), genetic (Joyce et al. 1994), and informational (e.g., Korzeniewski 2001) definitions of life, tend to emphasize reproduction. In this context, reproduction and replication should not be conflated: replication is perfect (or nearly perfect) reproduction. Organisms reproduce, genes replicate. Models of the origins of life typically bifurcate along the same lines as definitions of life. Gene-first models of the origins of life (e.g. Gilbert 1986) parallel evolutionary-genetic definitions, and metabolism-first theories (e.g., Oparin 1924, Eakin 1963, Morowitz 1968, Hartman 1975, Shapiro 2006, see also Orgel 2008 for counter-arguments) parallel metabolism-thermodynamic based definitions of life. Systemic accounts (Bunge 2003), cluster kinds (Diéguez 2013; Ferreira Ruiz and Umerez 2018), lists (Joyce et al. 1994), synthesis (Dyson 1999), neo-vitalist accounts (Canguilhem 1966), and autocatalytic accounts (Eschenmoser 2007; Pross 2012) are examples of the third approach.

Numerous other models are possible. Many contemporary advocates of the RNA World (e.g., Cech 1993; Lazcano 2010) contend that primitive autocatalytic “metabolic” cycles may have been required to generate self-replicating collections of RNA oligomers. Why postulate a double origin involving the emergence of first a metabolic form of life which may have independently recurred several times and then a genetic form of life (or vice versa)? However, a reproducing form would necessarily remain inert until metabolic or environmental forces acted upon it. The emergence of a proto-metabolic system may represent a complex, non-living system which is nonetheless a necessary stage in the origins of life. Alternatively, the emergence of self- or mutually-catalytic interactions among RNA oligomers (disconnected from the metabolic pathways that carry out their synthesis), could similarly represent a necessary prebiotic stage in the emergence of life. In other words, the origins of self-organization or reproduction as we now know them may have been preceded by analogues or alternatives, suggesting that the question of priority is at best underspecified. To further complicate discussion, metabolism and reproduction may be equivalent at some level of description (e.g., Eschenmoser and Kiskakürek 1996; Pross 2012).

Whether one focuses on one factor of life and treats the other(s) as arriving later may depend on a choice of definitions or understanding of the relevant factors. This brings us to a central problem with tailoring a model of the origins of life closely on a definition of life: there may be little reason to suppose that one could extract a causal “recipe” for life (in general, or specifically with regard to life on Earth) from a description of the fundamental properties of life (even assuming that we know what they are) (Cleland 2013; Cleland 2020). It is not true in general that knowledge of the identifying properties of a material thing will reveal how it was produced. As an analogy, descriptions of quartz at the macro-mineralogical level (hardness, crystal habit, etc.) or the molecular level (SiO_2) both explain how to identify quartz. Neither, however, explains how quartz is produced under natural conditions. Geochemists have discovered that quartz crystallizes in magma and precipitates in hot springs, and there are possibly other ways in which it forms under conditions very different from those found on Earth. Moreover, there is a fear in any subject that our observations are ‘theory-laden’ and so what appears essential to us is merely essential to the implicit theoretical commitments with which we approach life (Kuhn 1962). The point is a lack of clarity about one’s commitments to the nature of life can lead to theoretical confusions and ambiguities over what needs to be included in a model of the origins of life, and in fact, a commitment to a theory or definition of life may not even be entirely necessary for the sake of making progress in understanding steps in the emergence of life.

Top-Down Issues

‘Top-down’ approaches to origins-of-life research begin with contemporary life on Earth and use the tools of comparative biology and systematics to infer the nature of prior biological states, with the hope that such extrapolations may carry all the way back to life’s origins. Top-down approaches often aim to infer the nature of LUCA, its contemporaries, and sometimes, the common ancestors of the genes present in either (e.g., Weiss et al. 2016; Giovannelli et al. 2017; Koonin 2016; Koonin et al. 2017; Williams et al. 2017; Martin et al. 2016; Tuller et al. 2010; Cornish-Bowden and Cárdenas 2017). Some of these approaches consider LUCA to be close to the origin of life and thus not significantly advanced (Martin et al. 2016). Others think that it lived at the time of the bifurcation of the Bacteria and Archaea and resembled a modern bacterium with various modern features, such as energy management by an ATP synthase working across a membrane (Tuller et al. 2010, Cornish-Bowden and Cárdenas 2017).

To date, there is little consensus as to what LUCA was, when it existed, and when life started, so there is potentially as much as a billion years of evolution preceding LUCA. While a billion years may be a somewhat comfortable time period for discussing microbial evolution post-LUCA, before LUCA the tempo of evolution could have varied.

There are at least three possibilities for the origins of life on Earth, as illustrated in Fig. 2:

- (1) only one kind of life emerged on the early Earth,
- (2) alternative forms of life, differing biochemically from ours in important ways, emerged on the early Earth, and
- (3) modern Earth life is the result of the fusion of two or more separate origins, which may or may not have been considered fully living by present criteria.

The efficacy of top-down approaches depends on whether A, B, or C is true, the extent to which past taxa have gone extinct, and whether other life origins or branches on Earth exist but remain undiscovered (Cleland and Copley 2005; Davies and Lineweaver 2005; Cleland 2020).

There may have been earlier biological states on which biology depended to reach its present state, but which were subsequently discarded or outcompeted during the evolutionary development of the biosphere (Caporael et al. 2013). As an example, it is generally held that RNA preceded DNA as an information storage molecule in living systems (Dworkin et al. 2003). This notion is supported by several lines of evidence, including that DNA monomers are often biosynthesized from RNA monomers, the use of RNA primers in replication, the composition of key components of the translation apparatus, and more. A considerable amount of evidence may have been erased as RNA shifted from an informational role to a subsidiary role. If biology has wiped away earlier traces of the lines of evidence we use to infer the nature of LUCA, then there may be little to learn and much to misinterpret about the origins of life from studying modern biology. This topic is complex and different authors are likely to have their own opinions.

One philosophical worry that has received some attention is whether pre-LUCA evolution should be considered “Darwinian” in the way we typically think of evolution occurring for modern life (Goldenfeld and Woese 2007; Fry 2000; Moreno and Ruiz-Mirazo 2009; Malaterre 2015). Investigating this is both an empirical and philosophical question, requiring details about chemical and early biological evolution as well as a thorough account of what “Darwinian” evolution means. There is such a wide disagreement on both accounts that it may prove impossible to come to a consensus regarding the events of early evolution, much less as to whether the overall process may qualify as “Darwinian.” For some, “Darwinism” can only refer to the “Modern Synthesis” of Mendelian inheritance and natural selection. For others, it is a looser notion of heredity, variation, and differential fitness (Lewontin 1970). Most evolutionary change is not Darwinian in either sense. For instance, in the study of the evolution of protein sequences, neutral evolution plays a much larger role (Kimura 1983). It is possible that processes during the emergence of life were “evolutionary” without being “Darwinian” as evidenced by the history of evolutionary thought before Darwin (Stott 2013; Bowler 1992; Bowler 2013), though the details matter greatly.

Early evolution may have involved processes that were, to some degree, different than contemporary evolutionary processes. For example, primitive cells may have lacked the strong digital heredity we now see in the form of genes, though there may have been an ancestor-descendant relationship that allowed for weak Darwinian processes. Whether one chooses to label such proto-biological processes as “Darwinian” may depend on their perceived similarity to current processes. In any event, some form of purely chemical (i.e., non-shape complementarity or information-based) evolution may have preceded more familiar Darwinian ones (Meléndez-Hevia et al. 2008).

Top-down and bottom-up approaches do not necessarily conflict, but neither do they necessarily coordinate. Bottom-up approaches, for example, can span the range of the explanatory projects discussed in the previous section, while top-down approaches are firmly historical in nature.

Communication across Scientific Disciplines

One of the most interesting aspects of the field of origins of life is how many disciplines must work together to address the most current and pressing questions (Griesemer 2008). Multidisciplinary endeavors, such as research into the origins of life, face special obstacles to defining themselves and organizing funding sources as multiple scientific communities must come together to determine the most important research questions, shared standards of

evidence, and methods to communicate across disciplinary boundaries (Eisenberg and Pellmar 2000; National Academy of Sciences 2005; Hilton and Cooke 2015). For historians and social scientists, origins-of-life studies provide an exciting opportunity to explore the social organization of research, the integration of empirical and theoretical results from many different backgrounds (biology, chemistry, geology, etc.), as well as the diversity of methods, theories, and principles each field uses and how they can be collectively productive.

In multidisciplinary science, the disciplinary elements retain their original identity as such fields represent an ad hoc mix of knowledge, information, and methods. By comparison, interdisciplinarity requires a higher degree of integration to create a holistic view which generally results in the emergence of a new disciplinary community, a new shared terminology, a new set of research questions, a communal understanding of research problems, and sometimes even an organizational framework for collaboration (Stokols et al. 2003, National Academy of Sciences 2005, Porter et al. 2007, Wagner et al. 2011).

The fields of study we presently recognize as “traditional sciences” often are more conceptually unified as they were constructed based on their perceived investigation of observationally discrete types of phenomena. Of course, many traditional sciences have only been demarcated in the last few centuries and even those faced the same issues as contemporary interdisciplinary sciences when considered over great temporal, cultural, or geographic distances. It may turn out that some of the issues which present themselves for multidisciplinary and interdisciplinary sciences are also manifested in traditional sciences, so the difference may be merely one of degree and not kind.

Philosophical, historical, and sociological research into similar cases in which dissimilar fields have needed to work together may yield insights into how origins-of-life research may avoid the pitfalls which have plagued other multidisciplinary and interdisciplinary endeavors. For example, the same term may be used by scientists with different backgrounds in slightly different ways (“conceptual slippage”). This may lead to a community that interacts in ways that are baroque and inconsistent from a philosophical perspective. Such disagreements may help science progress, hinder it, or simply waste researchers’ time.

An alternative to conceptual slippage is a holistic system designed by one researcher or research program, but this can be just as problematic when holistic systems come into conflict. We see this in debates about definitions of life, metabolism vs. reproduction first models, top-down vs. bottom-up models, and so on (see sections 2.1–2.4). Multidisciplinary sciences may have a harder time finding stability (as measured by identification, funding, and institutional commitment) than interdisciplinary sciences. Multidisciplinary sciences may see their component sciences come and go in popularity, periodically favoring some holistic program, or proceed with unexamined tensions and never develop a common language or research program.

Different disciplines use different methodologies, instruments, and techniques and thus, have different levels of acceptance for their findings. For instance, Benner et al. (2013) explained how chemistry, geology, biology, and physics operate and use models differently and as a result, had different standards of proof for discussing the claims of arsenic DNA made by researchers with insufficient knowledge and understanding of the differences in chemistry between phosphorus and arsenic (Wolfe-Simon et al. 2011). Similarly, a vigorous debate was created in the scientific community when it was argued that the ALH84001 meteorite contained evidence of past life on Mars (Dick and Strick 2005; Mesler and Cleaves 2015).

While such tensions can have long-term detrimental effects on scientific communities, they can also serve to crystallize the terms of debate. There have been some initiatives to develop more integrated approaches to origins-of-life research. In 1973, the International Society for

the Study of the Origin of Life (see www.issol.org) was established to bring together the scientific thoughts behind the contributions of Oparin, Urey, Miller, Fox, Ponnampertuma and others, and the Society has held triennial conferences since. In a similar effort, the Origins of Life Gordon Research Conferences have been held every other year since 1982. More recently, the ELSI Origins Network (EON) at the Earth-Life Science Institute with support from the John Templeton Foundation was launched to create a sustainable origins-of-life studies community by fostering its transformation from multidisciplinary to interdisciplinarity.

Partially as a result of these efforts, the number of peer-reviewed publications on the subject of origins of life has increased from about 50 to 400 per year between 1993 and 2011, and cross-disciplinary interaction has increased enormously among researchers from different disciplines as well (Taskin and Aydinoglu 2016, Aydinoglu et al. 2016, Aydinoglu and Taskin 2017). However, some of the challenges for the sustainability of origins-of-life research still remain. When better-established disciplines compete to claim limited available funding, establishing new academic structures or organizational frameworks can meet with resistance. Securing resources (funding, jobs, and graduate students) becomes a challenge. This makes origins-of-life studies vulnerable to changes that happen over time, such as periodically favoring some holistic programs or research questions. In such cases, it may help to look to experts with an understanding of the change of multidisciplinary sciences over time.

Historical and Sociological Considerations with Respect to Origins of Life

As in any scientific field of inquiry, one can trace the present state of the art via various discoveries, techniques, or publications and their subsequent canonization or rejection. That said, we can roughly split the history of origins-of-life studies into two parallel strands. The first deals with the development of origins of life as a research topic within empirical fields, primarily chemistry, Earth science and biology, while the second traces the development of theoretical questions relating to the origins of life, crossing between the fields of physics, evolutionary theory and computer science. The less-documented history and landscape of the second is explored more extensively here. For the reader interested in the first, extensive surveys of contemporary chemical models for the origins of life can be found elsewhere (Orgel 1998a, b; Fry 2000; Luisi 2006; Cleaves 2012; Ruiz-Mirazo et al. 2014).

The first strand can be divided into several phases:

- (1) The pre-systematization of biology period,
- (2) the post-systematization of biology period,
- (3) the chemistry period,
- (4) the molecular biology period, and
- (5) the informatics period.

Undoubtedly, other logical divisions could be proposed, and the ideas developed in these periods outstrip the names given here. We argue the major transitions in these periods are in the background availability of data and the ease of its collection as facilitated by increasingly sophisticated instrumentation or technique. Theory in this field has lagged significantly behind experiment and measurement, though increasingly, theory has become a driver of discovery in its own right.

Strand 1: From Chemistry to Molecular Biology

The Pre-Systematization of Biology Period

Drastic changes in the structure of biological theory were driven by the remarkable surveys of biological phenomena facilitated by the advent of global seafaring and trade encouraged during the Age of Exploration and the expansion of European colonialism. Indeed, while previous thinking on the organization of biology was largely produced by relatively localized thinkers (e.g. Aristotle), who had access to the biological diversity surrounding them or collected anecdotally, the global voyages of seminal theorists, such as Darwin and Wallace, contributed to their ability to construct general comparative theories of evolution. Even in earlier times, the theories of Linnaeus, Lamarck, Goethe and others were highly dependent on fossils and remains returned to Europe by colonial enterprises. In analogy, it is intriguing to speculate that the next revolutions in models of the universal aspects of biology may depend on exploration of far-flung solar system environments.

The Post-Systematization of Biology Period

The construction of phylogenetic trees to establish kinship has a long history. It can probably, at least intellectually, be traced to the genealogical trees that were already customarily constructed by virtue of the need to assure systematized inheritance of owned goods and responsibility for child-rearing (Fox 1967). The earliest attempts to aggregate organisms into systematic classification schemes (e.g. von Linn. et al. 1735/1964) relied on naked-eye observable similarities between organisms. While there are numerous aspects of such classification schemes which have since been discarded or superseded by molecular methods, this sort of hierarchical classification and the history it implies lies at the heart of the biological sciences. In his evolutionary theory, Lamarck introduced a temporal dimension in the classical, widely-accepted concept of the “Great Chain of Being” derived from the ideas developed by Aristotle and Plato (Lovejoy 1936; Bowler 1989). According to this view, organisms climb to more complex and perfect organization, starting at the bottom of the ladder with the lowest forms of life. Lamarck proposed that the first rung was populated by simple organisms which originated by spontaneous generation, hence integrating the traditional belief of the possibility of life being suddenly generated from inanimate matter into an evolutionary framework (Farley 1977; Bowler 1989). For his part, Darwin, despite having been reluctant to discuss the origins of life in public, never rejected the possibility of a kind of natural transition from pure chemistry to simple organisms (Peretó et al. 2009). His writing coincided with the Pasteur–Pouchet debate over whether the spontaneous generation of life was common (Farley and Geison 1974). The alternative, the maxim of Remak (1852) and Virchow (1859) that living cells must always come from other living cells, pushed the origins question back to a hypothetical first origination event. Several early scientists, including Haeckel, proclaimed that to be logically consistent an evolutionary scheme had to contemplate the appearance of the first organisms by natural mechanisms. He, and others of his period, postulated that there was no reason to assume an insurmountable barrier separating inert and living matter. The acceptance of this continuity, negated by many vitalist scientists of the time, was essential for the first attempts to experimentally synthesize living forms. The work of, among others, H. C. Bastian, J. Burke, A. L. Herrera, and S. Leduc can be retrospectively seen as sincere efforts to cross the frontier between the inanimate mineral world and the biological realm (Keller

2009; Strick 2009; Letelier et al. 2011; Barge et al. 2015; Cleaves et al. 2014; Campos 2015; Peretó 2016). The criticisms of vitalist scientists were justified based on their belief that non-material causes were involved in the functioning of life. Many materialist scientists, perhaps most prominently Jacques Loeb, qualified those early synthetic biology attempts as naive. Loeb's thinking embodied the transition from a colloidal chemistry view of the cell to a more chemically precise description based on the existence of macromolecules, such as proteins, and he was in a privileged position to proclaim the artificial synthesis of life as the ultimate goal of biology, although recognizing that his and his contemporaries' attempts were possibly premature (Deichmann 2009a, b, 2012). Present-day synthetic biologists share the same ambitions and incentives of the pioneers of one hundred years ago, and it is clear that a materialist approach remains seen as a prerequisite for developing a scientific approach to the origins of life (Fry 2000, 2006; Lazcano 2010).

The Chemistry Period

Friedrich Wöhler's demonstration of the abiotic synthesis of urea is often noted as a transition between pre-chemical and chemical conceptions of biology (Campaigne 1955). However, McKie (1944) described this as a chemical legend, saying that science does not advance in sudden leaps; in addition to McKie's comments, the "inorganic" ammonium cyanate that Wöhler used was of biological origin. Notable achievements in chemistry that have contributed to models for the origins of life include the elucidation of the structures of the biological molecules (including biopolymers) and their commonalities, the metabolic pathways which allow their synthesis and interconversion, as well as various other subtler inferences which can be scaffolded from this body of knowledge. One could add to this the discovery of the cofactors, driven largely by medicinal observations of nutrient-deficiency diseases, and the development of the chemiosmotic theory (Mitchell 1961). The development of experimental abiotic organic synthesis, later termed "prebiotic chemistry," during the 19th and 20th centuries converged within a historical framework with the Oparin and Haldane proposals for the origins of life on Earth (Oparin 1924; Haldane 1929). Prebiotic chemistry emerged as the study of abiotic synthesis leading to the origins of life under plausible primitive conditions, taking into consideration the data reported by planetologists, cosmochemists, and geologists (Bada and Lazcano 2003). Several laboratories are presently engaged in a "systems chemistry" approach to prebiotic chemistry aiming to functionally integrate diverse complex subsystems, such as lipid vesicles and self-replicating ribozymes (de la Escosura et al. 2015).

The Molecular-Biology Period

It is now widely recognized that all known life on Earth shares a generally common set of biochemical attributes, for example the use of DNA as an information storage reservoir, the use of various RNA/protein-based biomolecular machines as a means for decoding this information, the use of an essentially common genetic code, the use of common energy currencies and metabolic intermediates and the use of protein enzymes to mediate the majority of biochemical transformations. These commonalities may contribute to a circular definition which constrains thinking on the topic, as with the exclusion of RNA as an information storage molecule, which implicitly excludes RNA viruses from the realm of the "living." Importantly, the identification of these well-defined chemical systems relied on the development of analytical tools capable of assigning molecular identities to the agents of apparent transformations (see section 2.8). For

example, the realization that biological systems are predominantly composed of, besides water, “protein” preceded the modern chemical understanding of the mechanisms of protein biosynthesis. Likewise, the discovery of DNA as a molecular entity (Miescher 1871) long preceded its identification as the principal carrier of genetic information (Avery et al. 1944; Hershey and Chase 1952), which overlapped with the determination of its composition (Chargaff et al. 1952), and preceded the elucidation of its double-helical structure as the basis of the biochemical means of reproduction (Watson and Crick 1953; Judson 1979). The discovery process surrounding the structure and function of DNA and the central dogma of biology, which has been well-documented elsewhere, has provided a “Rosetta Stone” for the understanding of biology. While this has offered a unifying framework for understanding all known forms of life on Earth today, it has raised other conceptual issues, such as how the apparent complexity of the interdependency of the DNA–RNA–protein system arose, and whether this system is truly the first, first and only, or only surviving system to have originated on Earth (Joyce et al. 1987; Dworkin et al. 2003) (see section 2.3.) Although during the development of molecular biology in the twentieth century the question of what is life was eclipsed by the description of life in physicochemical terms, at present there is a renewed interest in the nature and origins of life in the context of systems and synthetic biology (Morange 2009, 2013, 2016).

The Informatics Period

This last period, which continues today, is marked by a significant increase in the ability to collect large amounts of salient data quickly and cheaply, such that even the earliest-career students and scientists may add to the repository of information about the Tree of Life in remarkably short order. For example, whole-genome sequencing and the rapid decrease in the cost of DNA sequencing has led to an explosion in notions of species diversity on Earth (Mora et al. 2011; Locey and Lennon 2016; Hug et al. 2016). Other techniques have also allowed for remarkably detailed molecular-scale descriptions of complex chemical systems, which were in retrospect relatively poorly described (Schmitt-Kopplin et al. 2010). Lastly, we note that the impact of developments in computing power and resources, which are now common accessories to all modern scientific research, cannot be underestimated in the current period. It seems likely they will play an accelerating role in the future of discoveries in this field. It should be noted that this brief history largely tracks thinking from the perspective of biology and chemistry. However, superposed on these discoveries has been the increasing realization that prebiotic chemistry occurred in a geological context and that the modern constructions of phylogenetics and geochemistry allow for some deconvolution of the interlinked effects biology has had on the evolution of Earth (Smith and Morowitz 2016). The composition, dynamics and evolution of the Earth have guided or at least prepared the playing field for biological evolution, and there is significant feedback between these two systems. The recognition of the tight coupling between the biosphere and geosphere can be traced to Vernadsky (McMenamin et al. 1998) and Henderson (1913), and in the context of the origins of life to Chamberlin and Chamberlin (1908), Oparin (1924) and Haldane (1929), among others. This remains a central thread in origins-of-life research, and contributions from geochemistry and planetary science should not be underestimated.

Strand 2: From Physics to Evolutionary Theory and Computation

As well as being a history of empirical measurements, the history of origins-of-life research is also a history of ideas. Here, in broad outline, the development of some of the more important theoretical ideas in the field is presented. While the history sketched in the previous section deals mainly with historical approaches to origins of life, this history covers mostly universal and synthetic approaches (in the senses described in section 2.2). Accordingly, the two histories cover largely disjoint sets of researchers, and the integration of these two strands will be an important future challenge. A common theme runs through many of the approaches below, termed here “circularity.” This is the idea that some process or phenomenon is a cause of itself, perhaps via a complex chain of intermediate causes (Rosen 1991; Letelier et al. 2011). As has been noted (Ruiz-Mirazo et al. 2004), there is a particular challenge in integrating this notion of circularity with that of open-ended evolution discussed below. The history of theory in origins-of-life research is difficult to tell in a linear way since so much of it was developed in parallel by different communities of researchers. Accordingly, we organize it according to multiple sub-themes rather than temporally.

Thermodynamics and Dissipative Structures

This class of ideas largely has its origins in the work of Boltzmann (1886/1974). Although isolated physical systems approach a state of thermodynamic equilibrium, living organisms can, and must, maintain themselves out of equilibrium while pushing their environment closer to equilibrium. This idea was popularized by Schrödinger (1944) who referred to “negative entropy” using the modern sign convention, and by Prigogine (1969), who observed that this applies not only to living organisms but to a host of purely physical phenomena (such as cyclonic storms), which he termed “dissipative structures.” He also coined the phrase “order through fluctuations”. A storm system arises through the (initially) exponential growth of a local fluctuation in an otherwise dynamically stable environment. The vertical temperature gradient promotes the ascension of warm air parcels through buoyancy forces, eventually leading to a quasi-stable dissipative structure, in the form of a cyclonic storm. This type of phenomenon could potentially serve as an analogue for life: a fluctuation in a nonequilibrium system grows exponentially due to external gradients and persists as it exports entropy to its environment while its own entropy remains steady or decreases with time. Thus, storm systems “feed on negative energy” just as do living organisms. Building on Alan Turing’s early work on self-organization (Turing 1990), Nicolis and Prigogine (1977) developed the theory of chemical systems that can form dissipative structures, for example, in reaction-diffusion systems (Pearson 1993). These have recently been reviewed by Goldbeter (2017), with particular emphasis on biological rhythms. Dissipative structures form spontaneously under the appropriate conditions, such as the storm systems described above and their analogy to the origins problem: that life arose as a physical response to chemical gradients on the early Earth, allowing them to be dissipated at a greater rate than by purely abiotic mechanisms (see also Smith and Morowitz 2016). How thermodynamic driving forces could drive organization in complex chemical reaction networks is explored further below.

Self-Organization: Autopoiesis, Metabolism-Repair Systems, the Chemoton and Related Ideas

The term “self-organization” has become something of a catch-all term for phenomena that appear organized without external cause. Self-organization is now recognized as a common and mundane feature of nature, rather than a distinguishing feature of life (e.g. Ball 1999). This includes dissipative structures but also other physical phenomena, such as self-organized criticality (Bak et al. 1987) and pattern formation in less physically-motivated systems, such as cellular automata (Wolfram 2002). Self-organizing phenomena have been seen as relevant to the origins of life, in that they demonstrate that complex forms of order can emerge from simple systems under certain conditions.

Models for self organization include:

1. **Autopoiesis**, which understands cognition and living systems in terms of dynamical systems theory and feedback loops that are circular (transform, destroy, repeat), and localized as the result of the processes themselves rather than some external cause (Maturana 1970, Maturana and Varela 1980, Maturana and Varela 1992, Beer 2004, but see also Ashby 1966, Letelier et al. 2011, and Froese and Stewart 2010). Maturana and Varela’s ideas have been subject to different interpretations and developed in different directions by multiple groups of researchers. Some hold that life simply *is* a network of processes, while others believe additional concepts are needed (as in Di Paolo’s 2005 concept of adaptivity). Some maintain that the network of processes must exist entirely within a surrounding membrane-like enclosure (Luisi 2006), while others allow processes that occur outside the physical boundary of the organism (Di Paolo 2009; Virgo et al. 2011; Froese et al. 2012), opening up the possibility that interactions with the environment might have played key roles even at the origins of life (Egbert et al. 2012; Froese et al. 2014).
2. **Metabolism-Repair (M,R) Systems** were developed by Rosen (1991), who saw living organisms as networks of processes “closed to efficient causation,” a phrase implying that all catalysts needed by an organism must be produced by the network of processes itself and cannot be imported from the environment (apart, perhaps, from metals). His work is highly mathematical, but attempts have been made to make Rosen’s work more intelligible to non-mathematicians (Cornish-Bowden et al. 2007, Letelier et al. 2011, Cárdenas et al. 2018). Rosen’s ideas are usually taken to consider single organisms, but he also saw them as relevant to webs of interactions between organisms (Cárdenas et al. 2018). The relationship between autopoiesis and metabolism-repair systems has been explored elsewhere (Letelier et al. 2003).
3. **The Chemoton** model, developed by Gánti, but translated and popularized by Szathmáry (e.g. Gánti 2000), treats living organisms as three interacting chemical cycles: metabolic, information/reproduction, and a process to achieve structural closure, the last of which Rosen did not consider (Cornish-Bowden 2015). Perhaps Gánti’s greatest insight was that although modern cells implement the key features of the chemoton using finely tuned catalysts and complex molecular machines (i.e., proteins and nucleic acids), it should also be possible to implement them using stoichiometrically coupled reactions, though he did not explain how such reactions would avoid competing side-reactions. This problem applies to all of the theories, but it is less severe with minimal models of metabolism-repair systems in which only a very small number of molecules need to have a high degree

of specificity (Piedrafita et al. 2010). Thus, in this view, the basic properties of metabolism, cellular individuality and evolution could all have arisen before the emergence of complex protein or ribozyme catalysts. This idea has been influential in work on reaction networks, as discussed below.

4. **Biological Autonomy**, as developed in particular by Kauffman (2000) and Moreno and Mossio (2015), builds on Maturana and Varela's ideas of closure but more explicitly focuses on thermodynamic constraints and the specific chemical relations that can achieve them. Biological autonomy (which is itself an underspecified term: it is not clear to what degree of autonomy from the environment constitutes true autonomy, and there is likely no conception of an organism which can be completely disconnected from its environment as organisms are inherently throughput systems) was explicitly proposed as a necessary but insufficient condition for life and as a possible intermediate step on the pathway from abiotic chemistry to modern cellular life (Ruiz-Mirazo et al. 2004). This concept was developed further by Kauffman (Kauffman 2004; Kauffman and Clayton 2009) to address the way that even the simplest organisms "act on their own behalf" in his concept of "autonomous agency." Kauffman emphasized that the self-preserving and self-reproducing dynamics of living organisms required preserving a work cycle capable of countering the incessant degradation imposed by the second law of thermodynamics.
5. **Autogenesis** (e.g. Deacon 2011; 2015), is the view that autonomous agency can be produced by the codependent linkage between complementary types of self-organizing processes. In isolation, self-organizing, self-replicating, autocatalytic, or self-assembling chemical processes are intrinsically self-limiting. Their potential to persist is lost when they eventually exhaust substrates or deplete local free energy. But codependent linkage between reciprocal catalytic processes and self-assembling containment processes such that each provides the supportive and limiting boundary conditions for the other can prevent loss of the synergy constraint linking these processes. Each thus limits the extent to which the other can deplete the environmental conditions it depends on. As a whole, the system effectively acts to repair damage, and if its components are more widely redistributed by damage, localization of repair processes can result in reproduction. This does not fit into either a metabolism-first or a replicator-first paradigm, though it is closer to the former since it has been used to account for the subsequent evolution of a simple form of molecular information (Deacon 2011; 2015; Deacon et al. 2014).

These theories, especially autopoiesis, metabolism-repair systems, and the chemoton, have left intellectual successors that are now central to origins-of-life research and have been discussed since at least the 1960s (Bahadur 1966; Kampitz and Fox 1969). Some of these ideas are now embodied in the concept of the "protocell," a membrane-enclosed compartment, inside which is either a "metabolic" set of autocatalytic reactions, an information-copying replicator, or both (Rasmussen et al. 2008; Rasmussen 2009). The conceptual and temporal relationship between a protocell, the progenote and LUCA remains somewhat blurry.

Replicators, Information and Evolution

Schrödinger (1944) predicted the existence of an "aperiodic crystal" to carry hereditary information, characterizing this as "order from order," as distinct from the "order from disorder" that occurs with the formation of what are now termed dissipative structures. For Schrödinger, life combined both of these sources of order. Von Neumann had begun thinking

about the instantiation of a “universal constructor” already in the 1940’s, though his ideas were published posthumously only two decades later (Von Neumann and Burks 1966). He suggested how a machine might be constructed which was capable of constructing any object using coded instructions, which could describe how to copy its own contents, effectively making a copy of itself. This process is analogous to the biological processes of translation and replication, although those molecular processes were not known at the time. Von Neumann’s replicator is related to the concept of a quine in computer science, self-reference in logic, and Gödel’s incompleteness theorems in mathematics.

Quasispecies Theoretical developments in the origins of life had a close relationship with the development of evolutionary theory in the twentieth century, with a great deal of cross influence. A key development was Eigen’s quasispecies model (Eigen and Schuster 1979). In the absence of highly evolved mutation repair mechanisms, one would expect mutation rates to be far higher in primitive organisms than in modern biology. The result, when mutation rates are high, is a much fuzzier kind of evolution, in which the steady state is dominated not by the single fittest sequence but by a broad “cloud” of many sequences, all constantly mutating among a set of accessible sequences. This cloud can be conceived of as a “quasispecies.” Although formulated in the context of prebiotic evolution, quasispecies theory was found to be useful in biology as well, particularly when dealing with viral evolution, in which mutation rates can be very high. It has since become a standard tool in the evolutionary theory toolbox (Domingo et al. 1985, Holland et al. 1992, Eigen 1993, Domingo and Holland 1997, Lauring and Andino 2010). A key result of quasispecies theory is a phenomenon called the “error threshold.” This says, in essence, that if the mutation rate is high then evolution might not converge to the highest fitness peak because less fit mutants are produced at such a high rate that they out-compete fitter sequences. This can take the form of a “sudden threshold,” where if the mutation rate is above a critical value the fitness peak suddenly becomes unobtainable (Nowak and Schuster 1989; Takeuchi and Hogeweg 2007; Nilsson and Snoad 2000). Eigen’s result showed that natural selection requires that organisms have a high fidelity mechanism of heredity, making the origins problem more difficult than might otherwise be assumed. This reasoning leads to what Maynard Smith and Szathmáry (1995) called Eigen’s paradox (Eigen 1971): to replicate a polymer with sufficiently high fidelity one needs complex enzymes, but complex enzymes cannot evolve without sufficiently high fidelity. This is no less of a problem for metabolism-first theories (or autopoiesis-first, chemoton-first, etc.) than it is for replicator-first theories, since no matter the starting point, systems must somehow end up with the modern biological mechanisms, or some equivalent, which one way or another solve this problem.

Hypercycles To resolve this paradox, Eigen and Schuster (1978) proposed the hypercycle model, a conceptual evolving system in which multiple short sequences exist, each coding for an enzyme (or, in more modern formulations, a catalyst) that is not capable of replicating every possible sequence with high fidelity, but which is able to selectively catalyze the replication of one of the other sequences. These sequences form a cycle, each catalyzing the replication of the next. However, while the hypercycle may solve Eigen’s paradox in principle, it is open to a different problem, as pointed out by Nee and Maynard Smith (1990). This is the problem of “parasites.” A sequence can mutate such that it no longer catalyzes replication of the next sequence in the cycle but still benefits from being replicated by the previous one. If this happens there is no immediate selective pressure against the mutant sequence and so such

“parasitic” sequences can take over the hypercycle, causing its overall self-replication to cease. The chemoton suffers from the same problem, as indeed does autopoiesis, as McMullin (2004) observed when attempting to model it in silico. One solution proposed for this problem, by Maynard Smith and Szathmáry (1995), is compartmentalization. The idea here is that the hypercycle chemistry could be contained in many separate compartments (e.g., vesicles), which need not all contain exactly the same set of sequences. In this case, if the hypercycle in one particular vesicle is taken over by parasites, it will be at a selective disadvantage compared to those vesicles that are parasite-free. This can be seen as a form of group selection at the molecular level. Maynard Smith and Szathmáry (1995) saw this as the first of their identified “major transitions in evolution.” This set of ideas, alongside those connected to autopoiesis and the chemoton, have reinforced the idea of the protocell as a key concept in origins of life (Rasmussen 2009). Origins-of-life and evolutionary theory also have connections at later stages in the evolution of life, for example, in the form of a model of the evolution of the genetic code and the transition from a mode of evolution dominated by horizontal gene transfer to one dominated by vertical descent (Vetsigian et al. 2006).

Reaction Networks, Autocatalysis and the Origin of Heredity

Living cells consist of both a system for storing, translating, and copying genetic information and a network of metabolic reactions that produce informational molecules. These are so tightly integrated into the same self-producing network of processes that it is hard to imagine either existing in its modern form without the other. Historically, both the empirical and the theoretical sides of the field have been split into two camps, known as “replicator first” and “metabolism first.” While the former group has focused attention on the possibility that evolution could occur among heteropolymers in the absence of enzymes as discussed in section 3.2.3 above, the latter are more focused on how chemistry resembling metabolism might arise in the absence of heteropolymers. While these have often been posed as diametrically opposed hypotheses, there is now a great deal of cross-communication between the two communities of researchers, along with a growing realization that this might not be the strictly either-or question it originally seemed. It should be noted that “metabolism first” denotes a very broad spectrum of approaches, in part because the term “metabolism” has different meanings to different researchers. To some, it refers specifically to small-molecule reactions that resemble extant biochemical pathways (e.g., the reductive tricarboxylic acid cycle), whereas to others, it has come to denote the entire network of processes that constitutes an individual, as per the concepts of autopoiesis and metabolism-repair systems discussed above. Thus the first group is more concerned with how specific reaction mechanisms could be catalyzed prebiotically, whereas the latter are more interested in what could lead to the emergence of a self-maintaining reaction network, all the better if it enables open-ended evolution, regardless of what chemical substrates it uses. A key concept for both groups is autocatalysis. One example is the so-called “formose reaction,” in which a small amount of glycolaldehyde (GA) is added to, or spontaneously forms, in a solution of formaldehyde under appropriate conditions (Boutlerow 1861; Breslow 1959). GA, a simple two-carbon sugar, reacts with formaldehyde, a simple one carbon compound, to produce a cycle of reactions that both add additional formaldehyde molecules or other aldehydes and ketones produced by the reaction, and split the products up into smaller molecules. The result is that more GA is produced, along with a variety of other sugars. Each GA molecule is causally responsible for

the production of more GA via a network of several reactions. This can be seen as a very simple kind of circularity. Morowitz (1968) and then Wächtershäuser (1988) proposed that autocatalytic cycles resembling the reductive tricarboxylic acid (rTCA) cycle (which had recently been proposed as perhaps the most ancient biological carbon-fixation pathway) could be catalyzed by minerals on the early Earth. Similar ideas have also been proposed by Russell and colleagues (Russell et al. 2005). Morowitz stressed that this would be a natural result of energy gradients on the early Earth, i.e., that autocatalytic cycles are close relatives of dissipative structures, but occurring in the domain of chemistry rather than physics. This idea had already been spelled out in some detail by King (1980), though not in a geochemical context (see also Virgo et al. 2016). Wächtershäuser's model stressed the importance of mineral surfaces in these processes, in particular of minerals that could reasonably be expected to be present in submarine hydrothermal environments which had recently been discovered, found to host ecosystems at least in part disconnected from solar energy, and proposed as sites for the origins of life (Corliss et al. 1981).

Cycles of intermediates, essential in the chemoton, are also essential for seeing the flaw in the traditional distinction between enzymes and metabolites. The distinction breaks down when it is recognized not only that all enzymes are metabolites, because they are synthesized within an organism, but also that all the metabolites in a cycle are also catalysts, because they are regenerated by the cycles in which they are used (Cornish-Bowden and Cárdenas 2007, 2008). Thus, such cycles may have played important roles in the origins of life. The notion of autocatalytic metabolic reaction networks, particularly in instances in which they were explicitly described, was quickly criticized on the grounds that under "reasonable prebiotic conditions" (a criticism generally levied by chemists to point to instances where chemistry in silico or on paper is unlikely to translate meaningfully to real-world chemistry) there would also be side reactions that remove intermediates from such cycles, producing products that do not contribute to the self-production and possibly making them too "leaky" to self-propagate. Taking the example of the rTCA cycle, which has at least eight enzymatically controlled steps depending on how one does the accounting, each step must proceed in high enough yields in order for the cycle to self-reproduce (Orgel 2008; King 1982). The self-reproduction of this cycle remains, to date, experimentally unvalidated, but results of Muchowski et al. (2017) are encouraging. While this yield/cycle completion problem is conceptually related to the problem of parasites in hypercycles, it is a fundamentally different problem in methodologically subtle but important ways (Szathmáry 2013). These criticisms highlight significant experimental and conceptual hurdles which must be overcome for these explanations to have strong explanatory value in this field. Besides the few proposed examples which seek to link modern biochemical pathways with geochemistry, and which have met with hard criticism, there are undoubtedly many ways that mutually catalytic chemistry could be engendered which need not have parallels or surviving parallels in modern biochemistry. The emergence of the field of systems chemistry (Nitschke 2009; von Kiedrowski et al. 2010) and the quick realization of its potential importance to origins questions (Ruiz-Mirazo et al. 2014) highlights the hopes scientists have that such approaches may be fruitful. Another approach to autocatalysis is that of Kauffman (1993), who proposed a prebiotic scenario in which peptides (or some other polymer, such as RNA) would be able to selectively catalyze ligation and cleavage of other specific peptides (or ribozymes). In his model, for every such reaction, there is a probability that it is catalyzed by any other polymer present in the system. He showed mathematically that this model has a phase transition. According to his analysis, at certain threshold values of system component diversity and probabilities of catalysis, very large autocatalytic sets may

form, in which a large number of species all catalyze the production of at least one other member of the set, and which are also catalyzed by at least one other member of the set. Friston (2013) has proposed a model that resembles Kauffman's in some respects and reaches the similar conclusion that "biological self-organization is not as remarkable as one might think." However, it is not clear whether Kauffman's model provides a realistic model of peptide catalysis with respect to energetics or specificity. The indication that phase transition behavior may be displayed by such sets is nevertheless potentially important for origins research, as it suggests that under at least some theoretically possible conditions, it can be easier to create a large, complicated system whose many parts play loose functional roles than it is to create a smaller system with a minimum of functional parts (which is perhaps more similar to the present actualized biological state of affairs). This suggests the possibility that the origins of life might not have been simple but instead might have passed through stages which were more complex than they might otherwise seemingly have needed to be, and consequently, approaches to understanding the origins of life which seek to draw short and straight lines between modern biology and prebiotic chemistry may be misguided. A serious problem with Kauffman's model is that although it explains how large systems can arise from simple properties of molecules, it does not explain why uncontrolled growth should not continue forever, until all that is left is tar (see Section 3.2.5).

A key challenge for metabolism-first approaches (and indeed all approaches) is to explain the emergence of heredity. If information-carrying polymers are the result of evolution, then it is crucial to understand the nature of evolution prior to their emergence and the reasons for their emergence. One concept that has been proposed for this is compositional heredity, the idea that early life was comprised of molecular aggregates or coacervate-like assemblies that reproduced by simple fission, with their offspring having a similar composition to their parents, which might provide "enough" heredity for more complex mechanisms to evolve (Segrè et al. 2000; Lancet et al. 2018). Whether hereditary information can be passed on by system dynamics, diffuse structural information, or exclusively by covalently-bonded linear polymers remains a contentious issue, and regardless of which, or which combination of these is correct, more work is needed to understand why, in present life, more sophisticated heredity mechanisms potentially emerge as a result.

A more abstract approach to the emergence of complex autocatalytic systems was pioneered by Fontana and Buss (1994), who defined an "artificial chemistry" in which simple computer programs (e.g., lambda calculus expressions) play the role of molecules. In their model, when two programs react, their "product" is determined by running one program with the other as an input. This was not intended as a realistic model of chemistry but as a way to conceptually probe how complex self-maintaining structures can emerge. A key result was that the system converged onto compositions that were collectively autocatalytic (or self-maintaining in their terminology), as well as being "closed," meaning that they contained only a small subset of all possible molecules. Nevertheless, the mechanisms involved in self-maintenance could be quite complex. These concepts were generalized by Dittrich and Di Fenizio (2007) into "chemical organization theory," which can be applied to more realistic models and real chemical systems.

Artificial chemistry has become an active research topic (Banzhaf and Yamamoto 2015) and now includes approaches such as that of Benkő et al. (Benkő et al. 2003a,b; Benkő et al. 2004; Benkő et al. 2005) and Andersen et al. (2013a, b), Andersen et al. 2014), that are attempting to more closely approximate the details of prebiotic chemical systems, such that they can be compared against experimental measurements. There is already a rich body of

computational work which can potentially be screened for applicability to real world chemistry. The cross-pollination of experimental and computational chemistry approaches to the question of origins is ripe for new discoveries.

“Tar,” Combinatorial Explosions and Alternative Chemistries

Modern researchers often use the terms “abiotic chemistry” and “prebiotic chemistry” almost interchangeably. To the extent that a useful distinction is to be had, “abiotic” refers to any chemistry which occurs without biological mediation (e.g., the chemistry which occurs in meteorites, should it be proven they played no role in the origins of life, or the photochemical transformations of smog), while “prebiotic” chemistry describes abiotic chemistry that is purported to be important for the origins of life, often simply because it generates compounds in present in contemporary organisms. Prebiotic chemistry may also include the study of compounds not present in contemporary biochemistry (see for example Cafferty and Hud 2015, and Chandru et al. 2016).

While views entertained before and during the nineteenth century might have allowed the possibility that life could arise independently from biologically-derived precursors, which is distinct from the notion that “imperfect” organisms may arise from more able ones, and from the notion that non-living sets of molecules not present in contemporary biology may actualize living states, it is now generally held that this is extremely unlikely and that there was some special set of attributes of environment and/or chemistry which allowed life to arise. A distinction between environmental biological and abiological organic chemistry was rarely deemed methodologically important until the Miller-Urey experiment (Miller 1953). By that time, serious doubts as to whether biology was the only way organic molecules could be formed had already been raised, and quashed (Campaigne 1955), and synthetic organic chemistry as a field was also extremely mature. Nevertheless, explicit investigation into the mechanisms by which completely abiological processes could produce organic chemical novelty, let alone chemical novelty with unusual properties, such as autocatalysis, are sparse in the literature before that time (e.g., Garrison et al. 1951). It is not clear when they were first investigated with the question of origins, as opposed to the mechanisms by which already biological organisms carried out transformations (Löb 1913).

The Miller-Urey experiment at the very least presented a clear methodological distinction between processes which were guided or unguided by human researchers (and implicitly to what extent this was philosophically tractable). Since the Miller-Urey experiment, it has been evident that prebiotic chemistry can produce diverse sets of products and generally may do so under the set of assumptions of what constitutes reasonable prebiotic conditions. While these often include the building blocks of modern biochemistry they also include a great deal of other molecules, and the overlap may be largely coincidental as the processes of production are distinct for the sake of the question at hand. Other purported prebiotic chemistries (which are often validated by the overlap of their products with the compounds isolable from carbonaceous meteorites) include HCN polymerization (Ferris et al. 1978), the formose reaction (Decker et al. 1982), Maillard chemistry (Baynes 2005) and Fischer–Tropsch-type chemistry (Anders et al. 1973). This diversity of products results from “combinatorial explosions”: a small number of reactive components can be put together in an exponentially increasing number of ways (Schuster 2000). These complex mixtures of products have often been referred to as “gunk” (Schwartz 2007), “tar” or “asphalt” (Benner et al. 2012) because they are often darkly colored, viscous and composed of many compounds, in contrast to what

synthetic organic chemists generally seek as products, i.e., simple mixtures from which single desired compounds can be easily isolated. Many researchers have approached this problem by attempting to constrain the chemistry so that only one or a few specific products are generated. Indeed, it is possible that there is some set of reactions and reaction conditions which might only produce modern biochemicals and do so in high yield, no matter how implausible. Planets offer large surface areas, and large amounts of time are available, so who is to say which set of conditions is impossible? It may be equally possible that this molecular diversity is not a problem to be avoided but instead played an essential role in the emergence of life (Chandru et al. 2018). Investigating this possibility requires not only further development of artificial chemistry models but also new experimental techniques (see for example Andersen et al. 2013a, b and Guttenberg et al. 2017).

A related question is why life is made of the particular set of building blocks that it is. Various computational works (Meringer et al. 2013; Cleaves et al. 2015; Ilardo et al. 2015; Zubarev et al. 2015) have shown that there are many more possible amino acids, intermediary metabolites or nucleosides than those used by life, and moreover, that the set used by life appears to be adapted to provide “optimal” coverage of the space of properties that such building blocks would be expected to have. Given the huge diversity of possible prebiotic molecules, it seems conceivable that the earliest ancestors of life were not made of the same chemical building blocks as modern life at all. If this idea is entertained, it would mean there are a very large number of chemical systems which require exploration to fully understand why life is constructed the way it is, and optimization and contingency deserve greater scrutiny than the simple products of abiotic chemistry.

Computational Approaches

A number of other techniques have become common in addressing questions about the origins of life. In the late twentieth century, it became feasible to simulate evolution computationally, beginning with Booker et al.’s (1989) genetic algorithm. This quickly gave rise to a number of early works in the field that became known as “Artificial Life.” Artificial Life, or ALife, does not refer exclusively to *in silico* evolutionary simulation study. Artificial Life refers more to a broad community of researchers and a loose set of common interests than to any particular methodology or agreed upon set of assumptions. These early works included Tom Ray’s *Tierra* (<http://life.ou.edu/tierra/>), in which self-replicating programs compete and “evolve”; Langton’s “loops” (Langton 1984), a self-replicating cellular automaton far simpler than von Neumann’s original concept; and Sims’ *Creatures* (Sims 1994), a three dimensional physical simulation in which creatures made of cuboid blocks “evolve” surprisingly complex behaviors. However, perhaps the greatest insight from *in silico* modeling of evolution is that *in silico* evolution seems to easily hit limits in terms of complexity, failing to produce further innovations. A famous early example is Ray’s *Tierra*, in which an initial self-replicating program evolves to become parasitic on other programs but further innovations do not occur after that. A similar example of evolution towards simplicity has been observed in an *in vitro* RNA system known as “Spiegelman’s monster” (Spiegelman et al. 1965). In both this and the *Tierra* case, the singular selection pressure for replication rate may have induced the complexity stagnation/regression. In contrast, biology has continued to produce innovations for several billion years and shows no sign of stopping. This capacity for (apparently) unbounded innovation has become known as “open-ended evolution,” and the problem

of fully understanding and reproducing it in simulations is a major current goal of ALife research (Taylor et al. 2016).

The framing of the problem is still in flux, with some groups seeking a numerical measure of complexity (Bedau and Packard 1991; Bedau et al. 2000) while others seek an explanation for more qualitative changes along the lines of Maynard Smith and Szathmáry's major transitions (Maynard Smith and Szathmáry 1995). This is important for origins-of-life research for similar reasons to Eigen's results regarding the hypercycle. Whatever form early evolution took, it must have had sufficient capacity for innovation to be able to reach the complexity of a modern cell. The fact that this has not yet been recapitulated in simulations reinforces the notion that they lack some fundamental understanding of what prerequisites permit this. For this reason, there is now substantial interest in the role of open-endedness in the origins of life (Ruiz-Mirazo et al. 2008, Gleiser et al. 2012, Adams et al. 2017, Adams and Walker 2017) including open-ended evolvability as part of a definition of life. However, others, following Maturana and Varela (1980) and Rosen (1991), regard evolvability as a corollary of life, not a prerequisite (Cárdenas et al. 2018; Cornish-Bowden and Cárdenas 2017). A related topic is the evolution of evolvability, i.e., the study of how the mechanisms of evolution are themselves subject to natural selection (Watson et al. 2016). Insights from simulations have played a key role in the development of this idea (Dawkins 1989; Altenberg 1994). A significant insight is that the variety of phenotypic changes that can be achieved by mutation is strongly dependent on the "genotype-phenotype map" (Wagner and Altenberg 1996), i.e., the biological mechanisms for reading and interpreting the genome.

Summary and Future Challenges

In summarizing theoretical and modeling approaches to the origins of life, we draw attention to two common themes. The first is the notion of *circularity*, that is that components of living systems are both causes and effects of themselves (Maturana 1970; Rosen 1991). "Circularity," rather than more technical terms such as "closure to efficient causation" or "operational closure," emphasizes that this basic idea is a common theme across many approaches to understanding the origins of life. The second is *open-endedness*, or the notion that life is not constant over time but always has the capacity for innovation or increasing complexity.

These two themes are to some extent in tension: circularity suggests constancy over time while open-endedness suggests change. Resolving this tension is an interesting challenge for future work. However, for most accounts, the circularity applies to a particular individual, and it is not an individual that evolves, but a population. Perhaps a much greater challenge is in integrating these synthetic and universal approaches with historical approaches. A full answer to the problem of the origins of life would include understanding how these properties of circularity and open-endedness arose in the geochemical context of the early Earth, what role they played in the transition from chemistry to biology and the evolution of modern life, and indeed, what roles they continue to play. How can the evidence from geology, chemistry, and biology be brought to bear on these questions? Conversely, how should insights from theory inform research in evolution and prebiotic chemistry? Integration of these approaches will undoubtedly open new perspectives on the question, but a full understanding of how this can be done can only come from greater communication and mutual understanding between the researchers involved.

Conclusions

The origins of life on Earth is one of the most important and most difficult unanswered questions in science. There are several ways of approaching its study, and the relative importance of these have changed over time. The scientific community agrees that both the approach and putative answer will likely draw on insights that will be multidisciplinary in nature. In this paper, we described historical and philosophical issues in the study of the origins of life, which we argue may help guide research as much as careful study of biochemistry or evolution. Philosophical issues included: (1) the nature of life, where we outlined several approaches that serve as alternatives to the traditional quest for a definition of life. (2) the explanatory project of origins-of-life research, in which we argued universal (true for origins everywhere), historical (descriptions of life's origin on Earth), and synthetic (possible ways of originating life) research programs overlap, are all interesting scientifically, but are not equivalent or directly transferable. (3) the research strategies for origins-of-life research, typically thought of as either top-down (inferring from current life to LUCA) or bottom-up (starting from non-life and working out how to get life started), which face different epistemological problems and require distinct philosophical commitments. (4) the metabolism-first vs. reproduction-first debate, which we challenged as presuming too much about the nature of life. (5) the nature of evolution prior to LUCA, which was certainly different from contemporary evolution, although we questioned whether the difference was greater than some of the vastly diverse processes we see in life today. (6) the nature of entities prior to LUCA, which are sometimes thought of as loose communities, though whether such communities can serve as ancestral requires rethinking the nature of ancestors; (7) the challenges of origins-of-life which are common to multidisciplinary sciences: competing research programs, diverse standards of evidence, and communicating across disciplinary divisions. (8) the development of new theories or tools, which offer opportunities for new avenues of research, but may also constrain others. We also discussed two complementary approaches toward writing the history of origins-of-life science, each of which spans great swaths of time and several revolutionary changes in the theories, tools, and practices of scientists interested in this area. Those two strands were: (1) From chemistry to molecular biology, tracing the paradigmatic changes made by international travel to develop comparative views of biology, systematizing biology as a historical science in which similarities of taxa were due to descent with modification, chemistry as a guiding force in exploring particular ways biotic polymers could form from their abiotically-produced parts, molecular biology and its focus on genetic material, and informatics, in which new technologies make the production of data vastly simpler than its interpretation. (2) The second strand was from the theoretical questions relating to the origins of life, crossing between the fields of physics, evolutionary theory and computer science. Here the vastly different approaches led by thermodynamics, self-organization, replicators, reaction networks, and artificial life have led to distinct research programs that reveal intriguing features of life and perhaps even its nature or origin. The history of a field and its philosophical commitments shape how we conceive of the problem as well as what would be acceptable as a solution. The ways the understanding of the questions being asked are historically situated, and the ways research programs are loaded with philosophical commitments, many of which are not shared by all researchers in the relevant fields, can induce disagreements. Addressing and acknowledging these disagreements and their histories can go a long way toward resolving debates in this field.

Acknowledgements The authors wish to thank the Earth-Life Science Institute Origins Network (EON) at the Tokyo Institute of Technology for hosting the meeting History and Philosophy of Origins Research Workshop that took place on August 2016 in Tokyo, Japan, which this publication is based. This project/publication was supported by the ELSI Origins Network (EON), which is supported by a grant from the John Templeton Foundation. The opinions expressed in this publication are those of the authors and do not necessarily reflect the views of the John Templeton Foundation. T.F.'s work on this article was supported by an ELSI Origins Network (EON) Long-Term Visitor Award and by an UNAM-DGAPA-PAPIIT project (IA104717).

References

- Adams A, Walker SI (2017) Real-world open-ended evolution: a league of legends adventure. *International Journal of Design & Nature and Ecodynamics* 12:458–469
- Adams A, Zenil H, Davies PCW, Walker SI (2017) Formal definitions of unbounded evolution and innovation reveal universal mechanisms for open-ended evolution in dynamical systems. *Sci Rep* 7:997
- Altenberg L (1994) The evolution of evolvability in genetic programming. *Advances in Genetic Programming* 3: 47–74
- Anders E, Hayatsu R, Studier MH (1973) Organic compounds in meteorites. *Science* 182:781–790
- Andersen JL, Andersen T, Flamm C, Hanczyc MM, Merkle D, Stadler PF (2013a) Navigating the chemical space of HCN polymerization and hydrolysis: guiding graph grammars by mass spectrometry data. *Entropy* 15: 4066–4083
- Andersen JL, Flamm C, Merkle D, Stadler PF (2013b) Inferring chemical reaction patterns using rule composition in graph grammars. *J Syst Chem* 4:4
- Andersen JL, Flamm C, Merkle D, Stadler PF (2014) Generic strategies for chemical space exploration. *Int J Comput Biol Drug Design* 7:225–258
- Ashby WR (1966) *Design for a Brain: the origin of adaptive behaviour*. Chapman and Hall, London
- Avery OT, MacLeod CM, McCarty M (1944) Studies on the chemical nature of the substance inducing transformation of pneumococcal types: induction of transformation by a desoxyribonucleic acid fraction isolated from pneumococcus type III. *J Exp Med* 79:137–158
- Aydinoglu AU, Taskin Z (2016) Origins of life research: a bibliometric approach. *Orig. Life Evol. Biosph.* 48: 55–71. <https://doi.org/10.1007/s11084-017-9543-4>
- Aydinoglu AU, Allard S, Mitchell C (2016) Measuring diversity in disciplinary collaboration in research teams: an ecological perspective. *Research Evaluation* 25:18–36. <https://doi.org/10.1093/reseval/rvv028>
- Bada JL, Lazcano A (2003) Prebiotic soup - revisiting the Miller experiment. *Science* 300:745–746
- Bahadur K (1966) Synthesis of Jeeewanu: the protocell. Ram Narain Lal Beni Prasad. Uttar Pradesh, India
- Bains W (2004) Many chemistries could be used to build living systems. *Astrobiology* 4:137–167
- Bak P, Tang C, Wiesenfeld K (1987) Self-organized criticality: an explanation of the $1/f$ noise. *Phys Rev Lett* 59: 381–384
- Ball P (1999) *The self-made tapestry: pattern formation in nature*. Oxford University Press
- Banzhaf W, Yamamoto L (2015) *Artificial chemistries*. MIT Press, Cambridge
- Barge LM, Cardoso SS, Cartwright JH, Cooper GJ, Cronin L, De Wit A, Doloboff IJ, Escribano B, Goldstein RE, Haudin F (2015) From chemical gardens to chemobryonics. *Chem Rev* 115:8652–8703
- Baynes JW (2005) *The Maillard reaction: chemistry at the interface of nutrition, aging, and disease*. New York Academy of Sciences, New York
- Beatty J (1997) Why do biologists argue like they do? *Philos Sci* 64:S432–S443
- Bedau MA, Packard NH (1991) Measurement of evolutionary activity, teleology, and life. In *Artificial Life II*. Santa Fe Institute Studies in the Sciences of Complexity, Vol. X, (Redwood City, CA: Addison-Wesley, 1992), pp. 431–461
- Bedau MA, McCaskill JS, Packard NH, Rasmussen S, Adami C, Green DG, Ray TS (2000) Open problems in artificial life. *Artif Life* 6:363–376
- Beer RD (2004) Autopoiesis and cognition in the game of life. *Artif Life* 10:309–326
- Benkő G, Flamm C, Stadler PF (2003a) Generic properties of chemical networks: artificial chemistry based on graph rewriting. In *Advances in Artificial Life, ECAL*, Dortmund, Germany:10–19
- Benkő G, Flamm C, Stadler PF (2003b) A graph-based toy model of chemistry. *J Chem Inf Comput Sci* 43(4): 1085–1093
- Benkő G, Flamm C, Stadler P (2004) Multi-phase artificial chemistry. The logic of artificial life: abstracting and synthesizing the principles of living systems, 1, 10–20

- Benkő G, Flamm C, Stadler P (2005) Explicit collision simulation of chemical reactions in a graph based artificial chemistry. *Advances in Artificial Life*:725–733
- Benner SA, Kim H-J, Carrigan MA (2012) Asphalt, water, and the prebiotic synthesis of ribose, Ribonucleosides, and RNA. *Acc Chem Res* 45:2025–2034
- Benner SA, Bains W, Seager S (2013) Models and standards of proof in crossdisciplinary science: the case of arsenic DNA. *Astrobiology* 13:510–513
- Bich L, Green S (2017) Is defining life pointless? Operational definitions at the frontiers of biology. *Synthese*:1–28
- Boltzmann, L. (1886/1974). The second law of thermodynamics. In *Theoretical Physics and Philosophical Problems*. Edited by McGuinness, B. F. (ed. Springer), p. 24
- Booker LB, Goldberg DE, Holland JH (1989) Classifier systems and genetic algorithms. *Artif Intell* 40:235–282
- Boutlerow A (1861) Formation synthétique d'une substance sucrée. *C R Acad Sci* 53:145–147
- Bowler PJ (1989) *Evolution: the history of an idea*. University of California Press, Berkeley
- Bowler PJ (1992) The eclipse of Darwinism: anti-Darwinian evolution theories in the decades around 1900. Johns Hopkins University Press, Baltimore
- Bowler PJ (2013) *Darwin deleted: imagining a world without Darwin*. University of Chicago Press, Chicago
- Breslow R (1959) On the mechanism of the formose reaction. *Tetrahedron Lett* 1(21):22–26
- Bunge M (2003) *Emergence and convergence: qualitative novelty and the unity of knowledge*. University of Toronto Press, Toronto
- Cafferty BJ, Hud NV (2015) Was a pyrimidine-pyrimidine base pair the ancestor of Watson-Crick base pairs? Insights from a systematic approach to the origin of RNA. *Isr J Chem* 55:891–905
- Cairns-Smith AG (1971) *The life puzzle: on crystals and organisms and on the possibility of a crystal as an ancestor*. University of Toronto Press
- Campaigne E (1955) Wohler and the overthrow of vitalism. *J Chem Educ* 32:403
- Campos LA (2015) *Radium and the secret of life*. University of Chicago Press, Chicago
- Canguilhem G (1966) Le concept et la vie. *Revue philosophique de Louvain* 64:193–223
- Caporael LR, Griesemer JR, Wimsatt WC (eds) (2013) *Developing scaffolds in evolution, culture, and cognition*. (Vienna series in theoretical biology). MIT Press, Cambridge
- Cárdenas ML, Benomar S, Cornish-Bowden A (2018) Rosennean complexity and its relevance to ecology. *Ecol Complex* 35:13–24
- Cech TR (1993) The efficiency and versatility of catalytic RNA: implications for an RNA world. *Gene* 135:33–36
- Chamberlin T, Chamberlin R (1908) Early terrestrial conditions that may have favored organic synthesis. *Science* 28:897–911
- Chandru K, Gilbert A, Butch C, Aono M, Cleaves HJ II (2016) The abiotic chemistry of thiolated acetate derivatives and the origin of life. *Sci Rep* 6:29883
- Chandru K, Guttenberg N, Giri C, Hongo Y, Butch C, Mamajanov I, Cleaves HJ (2018) Simple prebiotic synthesis of high diversity dynamic combinatorial polyester libraries. *Comm Chem* 1(1):30
- Chargaff E, Lipshitz R, Green C (1952) Composition of the desoxyribose nucleic acids of four genera of sea-urchin. *J Biol Chem* 195:155–160
- Cleaves HJ (2012) Prebiotic chemistry: what we know, what we don't. *Evol Edu Outreach* 5:342–360
- Cleaves HJ, Lazcano A, Mateos IL, Negrín-Mendoza A, Peretó J, Silva E (2014) Herrera's 'Plasmogenia' and other collected works: early writings on the experimental study of the origin of life. Springer, New York
- Cleaves HJ, Meringer M, Goodwin J (2015) 227 views of RNA: is RNA unique in its chemical isomer space? *Astrobiology* 15:538–558
- Cleland CE (2013) Conceptual challenges for contemporary theories of the origin of life. *Curr Org Chem* 17:1704–1709
- Cleland CE (2020) *The quest for a universal theory of life. Searching for life as we Don't know it*. Cambridge University Press
- Cleland CE, Chyba CF (2007) *Planets and life: the emerging science of astrobiology*. Cambridge University Press, Cambridge
- Cleland CE, Copley SD (2005) The possibility of alternative microbial life on earth. *Int J Astrobiol* 4:165–173
- Corliss J, Baross J, Hoffman S (1981) A hypothesis concerning the relationship between submarine hot springs and the origin of life on earth. *Oceanol Acta* 4:59–69
- Cornish-Bowden A (2015) Tibor Gánti and Robert Rosen: contrasting approaches to the same problem. *J Theor Biol* 381:6–10
- Cornish-Bowden A, Cárdenas ML (2007) Organizational invariance in (M,R) systems. *Chem Biodivers* 4:2396–2406
- Cornish-Bowden A, Cárdenas ML (2008) Self-organization at the origin of life. *J Theor Biol* 252:379–387
- Cornish-Bowden A, Cárdenas ML (2017) Life before LUCA. *J Theor Biol* 434:68–73

- Cornish-Bowden A, Cárdenas ML, Letelier JC, Soto-Andrade J (2007) Beyond reductionism: metabolic circularity as a guiding vision for a real biology of systems. *Proteomics* 7:839–845
- Cronin L, Krasnogor N, Davis BG, Alexander C, Robertson N, Steinke JH, Siepmann P (2006) The imitation game—a computational chemical approach to recognizing life. *Nat Biotechnol* 24:1203–1206
- Damer B, Deamer D (2015) Coupled phases and combinatorial selection in fluctuating hydrothermal pools: a scenario to guide experimental approaches to the origin of cellular life. *Life* 5:872–887
- Davies PC, Lineweaver CH (2005) Finding a second sample of life on earth. *Astrobiology* 5:154–163
- Dawkins R (1982) Universal Darwinism. In: Bendall DS (ed) *Evolution from molecules to men*. Cambridge University Press, Cambridge, UK, pp 403–425
- Dawkins R (1989) In: Langton CG (ed) *Artificial life: the proceedings of an interdisciplinary workshop on the synthesis and simulation of living systems*, vol 6. Addison–Wesley, Reading, pp 201–220
- De Duve C (1991) *Blueprint for a cell: the nature and origin of life*. North Patterson
- De la Escosura A, Briones C, Ruiz-Mirazo K (2015) The systems perspective at the crossroads between chemistry and biology. *J Theor Biol* 381:11–22
- Deacon TW (2011) *Incomplete nature: how mind emerged from matter*. W. W. Norton, New York
- Deacon T (2015) Steps to a science of biosemiotics. *Green Letts* 19:293–311
- Deacon, T., Srivastava, A. & Bacigalupi, J. (2014). The transition from constraint to regulation at the origin of life. *Frontiers in Bioscience* 19, 945–957
- Decker P, Schweer H, Pohlmann R (1982) Bioids: X. identification of formose sugars, presumable prebiotic metabolites, using capillary gas chromatography/gas chromatography—mass spectrometry of n-butoxime trifluoroacetates on OV-225. *J Chromatogr A* 244:281–291
- Deichmann U (2009a) Chemistry and the engineering of life around 1900: research and reflections by Jacques Loeb. *Biol Theory* 4:323–332
- Deichmann U (2009b) Molecular versus “colloidal”: controversies in biology and biochemistry, 1900–1940. *Bull Hist Chem* 32:105–118
- Deichmann U (2012) Crystals, colloids, or molecules?: early controversies about the origin of life and synthetic life. *Perspect Biol Med* 55:521–542
- Descartes R (1664/2010) *Treatise on Man*. In: *The Nature of Life: Classical and Contemporary Perspectives from Philosophy and Science*. Edited by M. A. Bedau & C.E. Cleland. New York, N.Y.: Cambridge University Press, p. 15–20. 9–14. (Original translation published in 1985 by J. Cottingham, R. Stoothoff, and D. Murdoch, Cambridge University Press. Original work published in 1664)
- Di Paolo EA (2005) Autopoiesis, adaptivity, teleology, agency. *Phenomenol Cogn Sci* 4(4):429–452
- Di Paolo EA (2009) Extended life. *Topoi* 28:9–21
- Di Paolo, E A., Noble, J. & Bullock, S. (2000). Simulation models as opaque thought experiments. In *Proceedings of artificial life VII: the seventh international conference on the simulation and synthesis of living systems*. (ed. MIT press). pp. 497–506. MIT, Cambridge, Mass
- Dick SJ, Strick JE (2005) *The living universe: NASA and the development of astrobiology*. Rutgers University Press, New Jersey
- Diéguez A (2013) Life as a homeostatic property cluster. *Biol Theory* 7(2):180–186 10/gd6gns
- Dittrich P, Di Fenizio PS (2007) Chemical organisation theory. *Bull Math Biol* 69(4):1199–1231
- Domingo E, Holland JJ (1997) RNA virus mutations and fitness for survival. *Annual Reviews in Microbiology* 51:151–178
- Domingo E, Martínez-Salas E, Sobrino F, de Torre JC, Portela A, Ortín J, VandePol S (1985) The quasispecies (extremely heterogeneous) nature of viral RNA genome populations: biological relevance—a review. *Gene* 40:1–8
- Douglas H (2016) Values in Science. In: *Oxford handbook of philosophy of science*. Oxford University Press, pp 609–630
- Dray W (1957) *Laws and Explanation in history*. Oxford University Press, Oxford, UK
- Dworkin JP, Lazcano A, Miller SL (2003) The roads to and from the RNA world. *J Theor Biol* 222:127–134
- Dyson F (1999) *Origins of life*. Cambridge Cambridge University Press
- Eakin RE (1963) An approach to the evolution of metabolism. *Proc Natl Acad Sci U S A* 49:360–366
- Egbert MD, Barandiaran X, Di Paolo EA (2012) Behavioral metabolism: the adaptive and evolutionary potential of metabolism-based chemotaxis. *Artif Life* 18:1–25
- Eigen M (1971) Selforganization of matter and the evolution of biological macromolecules. *Naturwissenschaften* 58:465–523
- Eigen M (1993) Viral quasispecies. *Sci Am* 269(1):42–49
- Eigen M, Schuster P (1978) The hypercycle. *Naturwissenschaften* 65:7–41
- Eigen M, Schuster P (1979) *The Hypercycle. A principle of natural self- organization*. Springer-Verlag, Berlin
- Eisenberg L, Pellmar TC (2000) *Bridging disciplines in the brain, behavioral, and clinical sciences*. National Academies Press, Washington D.C

- Eschenmoser A (2007) On a hypothetical generational relationship between HCN and constituents of the reductive citric acid cycle. *Chem Biodivers* 4:554–573
- Eschenmoser A, Kiskunreka MV (1996) Chemistry and the origin of life. *Helvetica Chimica Acta* 79:124
- Farley J (1977) The spontaneous generation controversy from Descartes to Oparin. The Johns Hopkins University Press, Baltimore
- Farley J, Geison GL (1974) Science, politics and spontaneous generation in nineteenth century France: the Pasteur-Pouchet debate. *Bull Hist Med* 48(2):161–198
- Feinberg G, Shapiro R (1980) Life beyond earth: the intelligent Earthling's guide to life in the universe. W. Morrow Quill Paperbacks, New York
- Ferreira Ruiz MJF, Umerez J (2018) Dealing with the changeable and blurry edges of living things: a modified version of property-cluster kinds. *Eur J Philos Sci* 8(3):493–518
- Ferris JP, Joshi PC, Edelson EH, Lawless JG (1978) HCN: a plausible source of purines, pyrimidines and amino acids on the primitive earth. *J Mol Evol* 11:293–311
- Fontana W, Buss LW (1994) What would be conserved if "the tape were played twice?". *Proc Natl Acad Sci* 91: 757–761
- Fox R (1967) Kinship and marriage: an anthropological perspective. Cambridge University Press, Cambridge
- Friston K (2013) Life as we know it. *J R Soc Interface* 10:20130475
- Froese T, Stewart J (2010) Life after Ashby: ultrastability and the autopoietic foundations of biological individuality. *Cybernetics & Human Knowing* 17:83–106
- Froese T, Ikegami T, Virgo N (2012) The behavior-based hypercycle: from parasitic reaction to symbiotic behavior. In C. Adami, D. M. Bryson, C. Ofria, & R. T. Pennock. In: *Artificial life 13: proceedings of the thirteenth international conference on the simulation and synthesis of living systems*. The MIT Press, Cambridge, pp 457–464
- Froese T, Virgo N, Ikegami T (2014) Motility at the origin of life: its characterization and a model. *Artif Life* 20: 55–76
- Fry I (1995) Are the different hypotheses on the emergence of life as different as they seem? *Biol Philos* 10:389–417
- Fry I (2000) Emergence of life on Earth: a historical and scientific overview. Rutgers University Press, New Jersey
- Fry I (2006) The origins of research into the origins of life. *Endeavour* 30:24–28
- Gánti T (2000) Levels of life and death. In (2003): *The Principles of Life*. Oxford University Press, Oxford, pp 1–10
- Gánti T (2003) *The Principles of Life*. Oxford University Press. In: Oxford and New York
- Garrison WM, Morrison D, Hamilton J, Benson A, Calvin M (1951) Reduction of carbon dioxide in aqueous solutions by ionizing radiation. *Science* 114:416–418
- Gilbert W (1986) Origin of life: the RNA world. *Nature* 319:6055
- Giovannelli D, Sievert SM, Hügl M, Markert S, Becher D, Schweder T, Vetriani C (2017) Insight into the evolution of microbial metabolism from the deepbranching bacterium, *Thermovibrio ammonificans*. *eLife* 6: e18990
- Gleiser M, Nelson B, Walker SI (2012) Chiral polymerization in open systems from chiral-selective reaction rates. *Orig Life Evol Biosph* 42:333–346
- Gogarten-Bockels M, Hilario E, Gogarten JP (1995) The effects of heavy meteorite bombardment on the early evolution—the emergence of the three domains of life. *Orig Life Evol Biosph* 25:251–264
- Goldbeter A (2017) Dissipative structures and biological rhythms. *Chaos: An Interdisciplinary Journal of Nonlinear Science*, 27:104612
- Goldenfeld N, Woese C (2007) Biology's next revolution. *Nature* 445:369–369
- Griesemer J (2008) Origins of life studies. *The Oxford Handbook for Philosophy of Biology*. (ed. Oxford University Press), 263–299. Oxford University, New York
- Guttenberg N, Virgo N, Chandru K, Scharf C, Mamajanov I (2017) Bulk measurements of messy chemistries are needed for a theory of the origins of life. *Philos Trans R Soc A Math Phys Eng Sci* 375(2109):20160347
- Haldane JBS (1929) The origin of life. *The Rationalist Annual* 148:3–10
- Hartman H (1975) Speculations on the origin and evolution of metabolism. *J Mol Evol* 4:359–370
- Henderson LJ (1913) *The fitness of the environment*. Macmillan, Basingstoke
- Hershey AD, Chase M (1952) Independent functions of viral protein and nucleic acid in growth of bacteriophage. *J Gen Physiol* 36:39–56
- Hilton ML, Cooke NJ (2015) Enhancing the effectiveness of team science. National Academies Press, Washington D.C
- Holland JJD, De La Torre JC, Steinhauer DA (1992) RNA virus populations as quasispecies. In: *Genetic diversity of RNA viruses*. Springer, Berlin Heidelberg, pp 1–20

- Holmes FL (2004) Investigative pathways: patterns and stages in the careers of experimental scientists. Yale University Press, New Haven
- Hug LA, Baker BJ, Anantharaman K, Brown CT, Probst AJ, Castelle CJ, Butterfield CN, Hemsdorf AW, Amano Y, Ise K, Suzuki Y (2016) A new view of the tree of life. *Nat Microbiol* 1:16048. <https://doi.org/10.1038/nmicrobiol.2016.48>
- Ilardo M, Meringer M, Freeland S, Rasulev B, Cleaves HJ (2015) Extraordinarily adaptive properties of the genetically encoded amino acids. *Sci Rep* 5:9414
- Jabr F (2013) Why life does not really exist. *Scientific American* <https://blogs.scientificamerican.com/brainwaves/why-life-does-not-really-exist/>. Accessed: May 29, 2014
- Joyce GF, Schwartz AW, Miller SL, Orgel LE (1987) The case for an ancestral genetic system involving simple analogues of the nucleotides. *Proc. Natl. Acad. Sci. U. S. A.* 84:4398–4402
- Joyce GF, Deamer DW, Fleischaker G (1994) Origins of life: the central concepts. Jones and Bartlett, Boston
- Judson HF (1979) The eighth day of creation: makers of the revolution in biology. Simon and Schuster, New York, New York
- Kampitz G, Fox SW (1969) The condensation of the adenylates of the amino acids common to protein. *Proc Natl Acad Sci U S A* 62:399–406
- Kauffman SA (1993) The origins of order: self-organization and selection in evolution. Oxford University Press, New York
- Kauffman SA (2000) Investigations. Oxford University Press, New York
- Kauffman SA (2004) Autonomous agents. In *Science and ultimate reality: Quantum theory, cosmology and complexity.* (ed. Cambridge University Press), pp. 654–666. Templeton Foundation, Philadelphia and London
- Kauffman SA, Clayton P (2009) On emergence, agency, and organization. *Biol Philos* 21:501–521
- Keller EF (2009) Making sense of life: explaining biological development with models, metaphors, and machines. Harvard University Press, Cambridge
- Kimura M (1983) The neutral theory of molecular evolution. Cambridge University Press, Cambridge
- King GAM (1980) Evolution of the coenzymes. *Biosystems* 13:23–45
- King GAM (1982) Recycling, reproduction, and life's origins. *BioSystems* 15:89–97
- Koonin EV (2016) Horizontal gene transfer: essentiality and evolvability in prokaryotes, and roles in evolutionary transitions. *F1000 Research* 5:F1000 Faculty Rev-1805
- Koonin EV, Makarova KS, Wolf YI (2017) Evolutionary genomics of defense Systems in Archaea and Bacteria. *Annu Rev Microbiol* 71:233–261
- Korzeniewski B (2001) Cybernetic formulation of the definition of life. *J Theor Biol* 209:275–286
- Kuhn TS (1962) The structure of scientific revolutions. University of Chicago Press, Chicago
- Lancet D, Zidovetzki R, Markovitch O (2018) Systems protobiology: origin of life in lipid catalytic networks. *J R Soc Interface* 15(144):20180159
- Langton CG (1984) Self-reproduction in cellular automata. *Physica D Nonlinear Phenom* 10(1–2):135–144
- Langton, C (1998) A new definition of artificial life. <http://www.chairemetal.com/cm03/intro.htm>
- Latour B (1987) Science in action. Harvard University Press, Cambridge
- Lauring AS, Andino R (2010) Quasispecies theory and the behavior of RNA viruses. *PLoS Pathog* 6:e1001005
- Lazcano A (2010) Historical development of origins research. *Cold Spring Harb. Perspect. Biol* 2:a002089
- Lazcano A, Miller SL (1996) The origin and early evolution of life: prebiotic chemistry, the pre-RNA world, and time. *Cell* 85:793–798
- Letelier J-C, Marín G, Mpodozis J (2003) Autopoietic and (M,R) systems. *J Theor Biol* 222:261–272
- Letelier J-C, Cárdenas ML, Cornish-Bowden A (2011) From L'Homme machine to metabolic closure: steps towards understanding life. *J Theor Biol* 286:100–113
- Lewontin R (1970) The Units of selection. *Annu. Rev. Ecol. Syst* 1:1–18
- Löb W (1913) Über das Verhalten des Formamids unter der Wirkung der stillen Entladung. Ein Beitrag zur Frage der Stickstoff-Assimilation. *Berichte der deutschen chemischen Gesellschaft* 46:684–697
- Lacey KJ, Lennon JT (2016) Scaling laws predict global microbial diversity. *Proc Natl Acad Sci* 113:5970–5975
- Lovejoy AO (1936) The great chain of being: A study of the history of an idea. Harvard University Press, Cambridge Mass
- Luisi PL (2006) The Emergence of Life: From Chemical Origins to Synthetic Biology. Cambridge University Press, Cambridge
- Machery E (2012) Why I stopped worrying about the definition of life... And why you should as well. *Synthese* 185:145–164
- Malaterre C (2015) Chemical evolution and life. *BIO Web of Conferences* 4:00002
- Mariscal C, Doolittle WF (2018) Life and life only: a radical alternative to life Definitionism. *Synthese*
- Martin WF, Weiss MC, Neukirchen S, Nelson-Sathi S, Sousa FL (2016) Physiology, phylogeny, and LUCA. *Microb Cell* 3:582–587

- Maruyama S, Ikoma M, Genda H, Hirose K, Yokoyama T, Santosh M (2013) The naked planet earth: Most essential pre-requisite for the origin and evolution of life. *Geosci Front* 4:141–165
- Maturana, H. (1970). *Biology of cognition Report 9 Biological Computing Laboratory*. University of Illinois, Urbana-Champaign
- Maturana HR, Varela FJ (1980) *Autopoiesis and cognition: the realisation of the living*. D. Reidel Pub. Co, London
- Maturana HR, Varela FJ (1992) *The tree of knowledge: the biological roots of human understanding*. Shambhala, Boston
- Maynard Smith J, Szathmáry E (1995) *The major transitions in evolution*. Oxford University Press, Oxford
- McKie D (1944) Wöhler's "synthetic" urea and the rejection of vitalism: a chemical legend. *Nature* 153:608–610
- McMenamin MAS, Margulis L, Vernadsky VI, Ceruti M, Golubic R, Guerrero R, Ikeda N, Ikesawa N, Krumbein WE, Lapo A, Lazcano A, Suzuki D, Tickell C, Walter M, Westbroek P (1998) *The biosphere*. Springer, New York
- McMullin B (2004) Thirty years of computational autopoiesis: a review. *ArtifLife* 10:277–295
- Meléndez-Hevia E, Montero-Gómez N, Montero F (2008) From prebiotic chemistry to cellular metabolism — the chemical evolution of metabolism before Darwinian natural selection. *J Theor Biol* 252:505–519
- Meringer M, Cleaves HJ, Freeland SJ (2013) Beyond terrestrial biology: charting the chemical universe of α -amino acid structures. *J Chem Inf Model* 53:2851–2862
- Mesler B, Cleaves HJ (2015) *A brief history of creation: science and the search for the origin of life*. W. W. Norton Incorporated, New York
- Miescher JF (1871) Ueber die chemische. Zusammensetzung der Eiterzellen *Medisch-chemische Untersuchungen* 4:441–460
- Miller SL (1953) A production of amino acids under possible primitive earth conditions. *Science* 117:528–529
- Mitchell P (1961) Coupling of phosphorylation to Electron and hydrogen transfer by a Chemi-osmotic type of mechanism. *Nature* 191:144–148
- Mora C, Tittensor DP, Adl S, Simpson AGB, Worm B (2011) How many species are there on earth and in the ocean? *PLoS Biol* 9:e1001127
- Morange M (2009) *Life explained*. Yale University Press, Connecticut
- Morange M (2013) *Histoire de la biologie moléculaire. La Découverte*, Paris
- Morange M (2016) *Une histoire de la biologie (inédit)*. Points, Paris
- Moreno A (2016) Some conceptual issues in the transition from chemistry to biology. *Hist Philos Life Sci* 38:1–16
- Moreno A, Mossio M (2015) *Introduction. Biological autonomy. A philosophical and theoretical enquiry*. Springer, Netherlands
- Moreno A, Ruiz-Mirazo K (2009) The problem of the emergence of functional diversity in prebiotic evolution. *Biol. Philos* 24:585–605
- Morowitz HJ (1968) *Energy flow in biology: biological organization as a problem in thermal physics*, 2nd edn. Academic Press, New York and London
- Morowitz HJ (1991) *The Thermodynamics of Pizza*. Rutgers University Press, Brownstown
- Muchowska KB, Varma SJ, Chevallot-Beroux E, Lethuillier-Karl L, Li G, Moran J (2017) Metals promote sequences of the reverse Krebs cycle. *Nat Ecol Evol* 1:1716–1721
- National Academy of Sciences, National Academy of Engineering, and Institute of Medicine (2005) *Facilitating Interdisciplinary Research*. Washington, DC: The National Academies Press. <https://doi.org/10.17226/11153>
- Nee S, Maynard Smith J (1990) The evolutionary biology of molecular parasites. *Parasitology* 100:S5–S18
- Nelson KE, Robertson PM, Levy M, Miller SL (2001) Concentration by evaporation and the prebiotic synthesis of cytosine. *Orig. Life Evol. Biosph.* 31:221–229
- Nicolis G, Prigogine I (1977) *Self-organization in nonequilibrium systems*. Wiley, New York
- Nilsson M, Snoad N (2000) Error thresholds for quasispecies on dynamic fitness landscapes. *Phys Rev Lett* 84: 191–194
- Nitschke JR (2009) Systems chemistry: molecular networks come of age. *Nature* 462:736–738
- Nowak M, Schuster P (1989) Error thresholds of replication in finite populations mutation frequencies and the onset of Muller's ratchet. *J Theor Biol* 137:375–395
- O'Malley M (2014) *Philosophy of microbiology*. Cambridge University Press, Cambridge
- Oparin AI (1924) *The origin of life*. Izd. Moskovshii Rabochil, Moscow
- Orgel LE (1998a) The origin of life - a review of facts and speculations. *Trends Biochem Sci* 23:491–495
- Orgel LE (1998b) The origin of life - how long did it take? *Orig Life Evol Biosph* 28:91–96
- Orgel LE (2008) The implausibility of metabolic cycles on the prebiotic earth. *PLoS Biol* 6:e18
- Pearson JE (1993) Complex patterns in a simple system. *Science* 261(5118):189–192
- Peretó J (2016) *Erasing Borders: a brief Chronicle of Early Synthetic Biology*. *J Mol Evol* 83:176–183
- Peretó J, Bada JL, Lazcano A (2009) Charles Darwin and the origin of life. *Orig. Life Evol. Biosph* 39:395–406

- Piedrafita G, Montero F, Morán F, Cárdenas ML, Cornish-Bowden A (2010) A simple self-maintaining metabolic system: robustness, autocatalysis, bistability. *PLoS Comput Biol* 6:e1000872
- Porter AL, Cohen AS, Roessner JD, Perreault M (2007) Measuring researcher interdisciplinarity. *Scientometrics* 72:117–147
- Powell R, Mariscal C (2015) Convergent evolution as natural experiment: the tape of life reconsidered. *Interface focus* 5:1–13
- Prigogine I (1969) Structure, dissipation and life. *Theoretical physics and biology*, 23–52
- Pross A (2012) What is life? How chemistry becomes biology. Oxford University Press, Oxford
- Rasmussen S (2009) Protocells: bridging nonliving and living matter. MIT Press, Cambridge
- Rasmussen S, Bedau MA, Chen L, Deamer D, Krakauer DC, Packard NH, Stadler PF (2008) Protocells: bridging nonliving and living matter. MIT Press, Cambridge
- Remak R (1852) Über extracellulare Entstehung thierischer Zellen und über Vermehrung derselben durch Theilung. *Arch Anat Physiol wiss Med* 19:47–57
- Rosen R (1991) Life itself. Columbia University Press, New York
- Ruiz-Mirazo K, Peretó J, Moreno A (2004) A universal definition of life: autonomy and open-ended evolution. *Orig. Life Evol. Biosph* 34:323–346
- Ruiz-Mirazo K, Umerez J, Moreno A (2008) Enabling conditions for ‘open-ended evolution. *Biol. Philos* 23:67–85
- Ruiz-Mirazo K, Briones C, de la Escosura A (2014) Prebiotic systems chemistry: new perspectives for the origins of life. *Chem Rev* 114:285–366
- Russell MJ, Hall AJ, Boyce AJ, Fallick AE (2005) 100th anniversary special paper: on hydrothermal convection systems and the emergence of life. *Econ Geol* 100:419–438
- Scharf C, Virgo N, Cleaves HJ, Aono M, Aubert-Kato N, Aydinoglu A, Barahona A, Barge LM, Benner SA, Biehl M, Brassler R, Butch CJ, Chandru K, Cronin L, Sebastian D, Jakob F, Hemlund J, Hut P, Ikegami T, Jun K, Kobayashi K, Mariscal C, McGlynn S, Menard B, Packard N, Pascal R, Pereto J, Rajamani S, Sinapayen L, Smith E, Switzer C, Takai K, Tian F, Ueno Y, Voytek M, Witkowski O, Hikaru Y (2015) A strategy for origins of life research. *Astrobiology* 15:1031–1042
- Schmitt-Kopplin P, Gabelica Z, Gougeon RD, Fekete A, Kanawati B, Harir M, Gebefuegi I, Eckel G, Hertkorn N (2010) High molecular diversity of extraterrestrial organic matter in Murchison meteorite revealed 40 years after its fall. *Proc Natl Acad Sci* 107:2763–2768
- Schrödinger E (1944) What is life? In: The physical aspect of the living cell. The University Press, Cambridge
- Schulze-Makuch D, Irwin LN (2006) The prospect of alien life in exotic forms on other worlds. *Naturwissenschaften* 93:155–172
- Schuster P (2000) Taming combinatorial explosion. *Proc Natl Acad Sci* 97:7678–7680
- Schwartz AW (2007) Intractable mixtures and the origin of life. *Chem Biodivers* 4:656–664
- Segrè D, Ben-Eli D, Lancet D (2000) Compositional genomes: prebiotic information transfer in mutually catalytic noncovalent assemblies. *Proc Natl Acad Sci* 97:4112–4117
- Shapiro R (2006) Small molecule interactions were central to the origin of life. *Q Rev Biol* 81:105–125
- Silverman, E. & Bullock, S. (2004). Empiricism in artificial life. In Proceedings of the ninth international conference on artificial life. (ed. MIT Press), pp. 534–539. MIT Cambridge, Mass
- Sims K (1994) Evolving 3D morphology and behavior by competition. *Artif life* 1:353–372
- Smith KC (2018) Life as adaptive capacity: bringing new life to an old debate. *Biol Theory*:1–17
- Smith E, Morowitz HJ (2016) The origin and nature of life on earth: the emergence of the fourth geosphere. Cambridge University Press, Cambridge
- Spiegelman S, Haruna I, Holland IB, Beaudreau G, Mills D (1965) The synthesis of a self-propagating and infectious nucleic acid with a purified enzyme. *Proc Natl Acad Sci U S A* 54(3):919–927
- Stokols, D., Fuqua, J., Gress, J., Harvey, R., Phillips, K., Baezconde-Garbanati, L., Unger, J., Palmer, P., Clark, M. A. & Colby, S. M. (2003). Evaluating transdisciplinary science. *Nicotine Tob Res* 5, S21-S39
- Stott R (2013) Darwin's Ghosts: In Search of the First Evolutionists, Bloomsbury, London. Strick, J. E. (2009). Sparks of life: Darwinism and the Victorian debates over spontaneous generation, Harvard University Press, Cambridge Mass. and London
- Strick JE (2009) Sparks of life: Darwinism and the Victorian debates over spontaneous generation. Harvard University Press.
- Szathmáry E (2013) On the propagation of a conceptual error concerning hypercycles and cooperation. *J Syst Chem* 4:1–4
- Szostak JW (2012) Attempts to define life do not help to understand the origin of life. *J Biomol Struct Dyn* 29: 599–600
- Takeuchi N, Hogeweg P (2007) Error-threshold exists in fitness landscapes with lethal mutants. *BMC Evol Biol* 7:15

- Taskin Z, Aydinoglu AU (2015) Collaborative multidisciplinary astrobiology research: a bibliometric study of the NASA astrobiology institute. *Scientometrics* 103:1003–1022. <https://doi.org/10.1007/s11192-015-1576-8>
- Taylor T, Bedau M, Channon A, Ackley D, Banzhaf W, Beslon G, Dolson E, Froese T, Hickinbotham S, Ikegami T, McMullin B, Packard N, Rasmussen S, Virgo N, Agmon E, Clark E, McGregor S, Ofria C, Ropella G, Spector L, Stanley KO, Stanton A, Timperley C, Vostinar A, Wiser M (2016) Open-ended evolution: perspectives from the OEE workshop in York. *Artif Life* 22:408–423
- Tuller T, Birin H, Gophna U, Kupiec M, Ruppin E (2010) Reconstructing ancestral gene content by coevolution. *Genome Res* 20:122–132
- Turing AM (1990) The chemical basis of morphogenesis. *Bull Math Biol* 52:153–197
- Vetsigian K, Woese C, Goldenfeld N (2006) Collective evolution and the genetic code. *Proc Natl Acad Sci* 103:10696–10701
- Virchow R (1859) *Die Cellular Pathologie*. August Hirschwald, Berlin
- Virgo, N., Egbert, M. D. & Froese, T. (2011). The role of the spatial boundary in autopoiesis. In *Advances in Artificial Life: Darwin Meets von Neumann*. 10th European Conference, ECAL 2009. (ed. Springer), pp. 234–241. Berlin
- Virgo, Ikegami McGregor (2016) Complex autocatalysis in simple chemistries. *Artificial life*. *J Sys Chem* 22:138–152
- von Kiedrowski G, Otto S, Herdewijn P (2010) Welcome home. *Systems Chemists! J Sys Chem* 1:1
- von Linné (Linnaeus) C (1735/1964) *Systema Naturae*, Facsimile of the First edition, Edited by Engel-Ledeboer, M. S. J. & Engel, H. Nieuwkoop, B. de Graaf
- Von Neumann J, Burks AW (1966) Theory of self-reproducing automata. *IEEE Trans Neural Netw* 5:3–14
- Wächtershäuser G (1988) Before enzymes and templates: theory of surface metabolism. *Microbiol Rev* 52:452–484
- Wagner GP, Altenberg L (1996) Perspective: complex adaptations and the evolution of evolvability. *Evolution* 50:967–976
- Wagner CS, Roessner JD, Bobb K, Klein JT, Boyack KW, Keyton J, Rafols I, Börner K (2011) Approaches to understanding and measuring interdisciplinary scientific research (IDR): a review of the literature. *J Infometr* 5:14–26
- Watson JD, Crick FHC (1953) Molecular structure of nucleic acids: a structure for deoxyribose nucleic acid. *Nature* 171:737–738
- Watson RA, Mills R, Buckley CL, Kouvaris K, Jackson A, Powers ST et al (2016) Evolutionary connectionism: algorithmic principles underlying the evolution of biological organisation in evo-devo, evo-eco and evolutionary transitions. *Evol Biol* 43(4):553–581
- Weiss MC, Sousa FL, Mrnjavac N, Neukirchen S, Roettger M, Nelson-Sathi S, Martin WF (2016) The physiology and habitat of the last universal common ancestor. *Nat Microbiol* 1:1–8
- Wetter GA (1958) *Der dialektische Materialismus und das Problem der Entstehung des Lebens: zur Theorie von AI Oparin*. Pustet
- Williams TA, Szöllösi GJ, Spang A, Foster PG, Heaps SE, Boussau B, Ettema TJG, Embley TM (2017) Integrative modeling of gene and genome evolution roots the archaeal tree of life. *Proc Natl Acad Sci* 114:E4602–E4611
- Wolfe-Simon F, Blum JS, Kulp TR, Gordon GW, Hoelt SE, Pett-Ridge J, Stolz JF, Webb SM, Weber PK, Davies PC (2011) A bacterium that can grow by using arsenic instead of phosphorus. *Science* 332:1163–1166
- Wolfram S (2002) *A new kind of science*. Wolfram Media, Champaign
- Zubarev DY, Rappoport D, Aspuru-Guzik A (2015) Uncertainty of prebiotic scenarios: the case of the non-enzymatic reverse tricarboxylic acid cycle. *Sci Rep* 5:1–7

Publisher's Note Springer Nature remains neutral with regard to jurisdictional claims in published maps and institutional affiliations.

Affiliations

Carlos Mariscal¹ · Ana Barahona² · Nathanael Aubert-Kato^{3,4} · Arsev Umur Aydinoglu^{5,6} · Stuart Bartlett^{3,7} · María Luz Cárdenas⁸ · Kuhan Chandru^{3,9,10} · Carol Cleland¹¹ · Benjamin T. Cocanougher^{12,13} · Nathaniel Comfort¹⁴ · Athel Cornish-Bowden⁸ · Terrence Deacon¹⁵ · Tom Froese^{16,17} · Donato Giovannelli^{3,18,19,20,21} · John Hernalund³ · Piet Hut^{3,18} · Jun Kimura²² · Marie-Christine

Maurel²³ · Nancy Merino^{3,24} · Alvaro Moreno²⁵ · Mayuko Nakagawa³ · Juli Peretó²⁶ · Nathaniel Virgo^{3,27,28} · Olaf Witkowski^{3,18} · H. James Cleaves II^{3,5,18,28,29}

✉ H. James Cleaves, II
hcleaves@elsi.jp

Carlos Mariscal
carlos@philbio.org

Ana Barahona
ana.barahona@ciencias.unam.mx

Nathanael Aubert-Kato
naubertkato@is.ocha.ac.jp

María Luz Cárdenas
cardenas@imm.cnrs.fr

Kuhan Chandru
kuhan@ukm.edu.my

Carol Cleland
Cleland@colorado.edu

Benjamin T. Cocanougher
btc23@cam.ac.uk

Nathaniel Comfort
nccomfort@gmail.com

Athel Cornish-Bowden
acornish@imm.cnrs.fr

Terrence Deacon
deacon@berkeley.edu

Tom Froese
t.froese@gmail.com

Donato Giovannelli
donato.giovannelli@unina.it

Jun Kimura
junkim@ess.sci.osaka-u.ac.jp

Marie-Christine Maurel
mariechristine.maurel@upmc.fr

Nancy Merino
nancymer@usc.edu

Alvaro Moreno
alvaro.moreno@ehu.es

Juli Peretó
pereto@uv.es

¹ Department of Philosophy, Ecology, Evolution, and Conservation Biology (EECB) Program, and Integrative Neuroscience Program, University of Nevada, Reno (UNR), Reno, Nevada, USA

² Department of Evolutionary Biology, School of Sciences, UNAM, 04510 CDMX, Coyoacán, Mexico

- ³ Earth-Life Science Institute, Tokyo Institute of Technology, Tokyo 152-8551, Japan
- ⁴ Department of Information Sciences, Ochanomizu University, Bunkyo-ku, Otsuka, 2-1-1, Tokyo 112-0012, Japan
- ⁵ Blue Marble Space Institute of Science, Washington, DC 20011, USA
- ⁶ Science and Technology Policies Department, Middle East Technical University (METU), 06800 Ankara, Turkey
- ⁷ Division of Geological and Planetary Sciences, California Institute of Technology, 1200 E California Blvd, Pasadena, CA 91125, USA
- ⁸ CNRS, BIP, IMM, Aix Marseille University, Marseille, France
- ⁹ Space Science Centre (ANGKASA), Institute of Climate Change, Level 3, Research Complex, National University of Malaysia, 43600 UKM Bangi, Selangor, Malaysia
- ¹⁰ Department of Physical Chemistry, University of Chemistry and Technology, Prague, Technická 5, 16628 Prague, 6, Dejvice, Czech Republic
- ¹¹ Department of Philosophy, University of Colorado, Boulder, Colorado, USA
- ¹² Howard Hughes Medical Institute Janelia Research Campus, Ashburn, VA 20147, USA
- ¹³ Department of Zoology, University of Cambridge, Cambridge CB2 3EJ, UK
- ¹⁴ Department of the History of Medicine, Johns Hopkins University, Baltimore, MD, USA
- ¹⁵ Department of Anthropology & Helen Wills Neuroscience Institute, University of California, Berkeley, CA, USA
- ¹⁶ Institute for Applied Mathematics and Systems Research (IIMAS), National Autonomous University of Mexico (UNAM), 04510 Mexico City, Mexico
- ¹⁷ Centre for the Sciences of Complexity (C3), National Autonomous University of Mexico (UNAM), 04510 Mexico City, Mexico
- ¹⁸ Institute for Advanced Study, Princeton, NJ 08540, USA
- ¹⁹ Department of Marine and Coastal Science, Rutgers University, 71 Dudley Rd, New Brunswick, NJ 08901, USA
- ²⁰ YHouse, Inc., NY 10159 New York, USA
- ²¹ Department of Biology, University of Naples “Federico II”, Via Cinthia, 80156 Naples, Italy
- ²² Department of Earth and Space Science, Osaka University, Machikaneyama-Chou 1-1, Toyonaka City, Osaka 560-0043, Japan
- ²³ UMR 7205-ISYEB, CNRS-MNHN-UPMC, 75005 Paris, France
- ²⁴ Department of Earth Sciences, University of Southern California, California, Los Angeles 90089, USA
- ²⁵ Department of Logic and Philosophy of Science, IAS-Research Centre for Life, Mind and Society, University of the Basque Country, Avenida de Tolosa 70, 20018 Donostia-San Sebastian, Spain
- ²⁶ Department of Biochemistry and Molecular Biology, University of València and Institute for Integrative Systems Biology I2SysBio (University of València-CSIC), València, Spain
- ²⁷ Max Planck Institute for Mathematics in the Sciences, Leipzig, Germany
- ²⁸ European Centre for Living Technology, Venice, Italy
- ²⁹ Center for Chemical Evolution, Georgia Institute of Technology, Atlanta, GA 30332, USA