

The dynamics of stock exchange based on the formalism of weak continuous quantum measurement

This article has been downloaded from IOPscience. Please scroll down to see the full text article.

2010 J. Phys.: Conf. Ser. 238 012035

(<http://iopscience.iop.org/1742-6596/238/1/012035>)

View [the table of contents for this issue](#), or go to the [journal homepage](#) for more

Download details:

IP Address: 178.150.150.162

The article was downloaded on 31/12/2011 at 07:22

Please note that [terms and conditions apply](#).

The dynamics of stock exchange based on the formalism of weak continuous quantum measurement

S Melnyk¹ and I Tuluzov²

¹ Yankel Kharkov National University of Radio Electronics, Lenin Ave.14, 61166, Kharkov Ukraine

² Kharkiv Regional Centre for Investment, of.405, vul. Tobolska 12, Kharkiv, 61072, Ukraine

E-mail: smelnyk@yandex.ru

Abstract. The problem of measurement in economic models and the possibility of their quantum-mechanical description are considered. It is revealed that the apparent paradox of such a description is associated with a priori requirement of conformity of the model to all the alternatives of free choice of the observer. The measurement of the state of a trader on a stock exchange is formally defined as his responses to the proposals of sale at a fixed price. It is shown that an analogue of Bell's inequalities for this measurement model is violated at the most general assumptions related to the strategy of the trader and requires a quantum-mechanical description of the dynamics of his condition. In the framework of the theory of weak continuous quantum measurements, the equation of stock price dynamics and the quantum-mechanical generalization of the F. Black and M. Scholes model for pricing options are obtained. The fundamental distinctions between the obtained model and the classical one are discussed.

1. Introduction

The presence of a subjective component makes the fundamental difference between the models of economic and social systems and the systems considered in physics. In the physical models, the measurement problem resides in the fact that the quantum-mechanical description of the dynamics of interaction between the object and measuring instrument cannot explain the mechanism of the collapse of the wave function. For the description of the measurements it is required to have an additional projective postulate and a classical description of the sensor. However, in this case the possibility of choosing the measured value by the observer (which determines the further evolution of the system) is not included in the formalism of the description. When describing the quantum system, one is to consider the choice of a way of monitoring to be predetermined a priori. Thereby, the logical problems appear when an active participant (a person) is involved in the monitoring mechanism. The referring issue of "Schrodinger's cat" is still a subject of debate. In this paper, we will consider an idealized model of a stock exchange, in which subjectivity and possibility of choice for players are included as basic elements of their description. It turns out that an attempt to describe such a system in the context of classical dynamics without taking into account the subjective behavior of players leads to inconsistencies [1]. However, the quantum-mechanical formalism allows remaining within the framework of objectivism. Until now, the most studies dealing with the quantum-mechanical generalizations of economic models introduced their properties on a phenomenological basis. In this paper, we will consider in detail the formation mechanism of quantum-mechanical properties of the

system regarded as a set of traders. Then we will examine the dynamics of stock price on a stock exchange, taking into account the impact of the results of its measurements on the psychology of traders. Such a model can be described by the formalism of weak continuous quantum measurements (WCQM). Thereby, an analog of the quantum mechanical uncertainty principle arises naturally in the description of the stock exchange dynamics. We arrive at a quantum-mechanical generalization of the F. Black and M. Scholes formula to calculate the "fair" price of options and parameters of optimum portfolio.

2. The psychological component of the "hidden variables" in quantum and classical models

Various versions of models based on the introduction of "hidden variables" have been an alternative for the quantum-mechanical description. The essence of these attempts of introducing the "hidden parameters" was an assumption that there were classical parameters which could not be measured in principle but which may explain the results of the quantum-mechanical experiments. In Bell's works, the possibility of experimental verification of this assumption was shown.

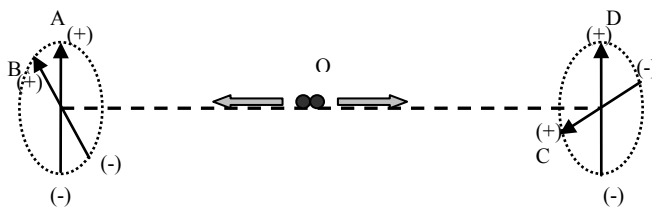

Figure 1. Scheme of the "spin" version of the EPR experiment, proposed by D. Bohm.

Table 1. The experimental data are pairs of results

	1	2	3	4	5	...
A	+	-	?	?	+	...
B	?	?	+	+	?	...
C	+	?	+	-	?	...
D	?	+	?	?	-	...
AC		AD	BC	BC	AD	...

Using the simplest "spin" version of the EPR experiment proposed by D. Bohm as an example, let us illustrate the essence of Bell's inequality and its fulfillment given the availability of the freedom of choice of an observer. It is assumed that two particles with the total spin 0 fly from point "O" in the opposite directions far apart (Figure 1). For each, one can measure the projection of the spin on one of two directions A or B for the first particle, and C or D for the second (lines A and D may coincide in the particular case). Thus, the experimental data are pairs of results that can be presented in tabular form. The cells corresponding to possible measurements, though not implemented for each pair of particles, are marked with "?". In this context, the results of not implemented (but possible) measurements play a role of the hidden variables. The results of the realized measurements allow us to calculate the statistical properties of the system. Both in quantum and classical systems, an assumption of the presence of the hidden variables is derived from an implicit assumption of the possibility of any other set of measurements. This assumption is an equivalent of the freedom of choice of an observer and independence of the properties of the monitoring system. In the experiment under consideration the possibility of such a description is reduced to the existence of the distribution $\rho_{ABCD}(\text{****})$ calculated from the observed correlations $\rho_{AC}(++)$; $\rho_{AC}(+-)$; $\rho_{AC}(+-)$ Otherwise, there is **no way to fill in the empty cells of the table** (the values of the hidden variables) so that for each pair of lines the observed correlating relations are realized. Hence, the result of observation of the properties of the first particle in one of two directions, for example A, should depend not only on the results of observations in the directions C or D, but also on which measurement of these possible measurements is made by the second observer.

In physical models, there is no clear mechanism of transferring information about the selection of the measurement with a superluminal velocity. Such states are called the entangled states of particles. Until recently, it was thought that the phenomenon of "entanglement" is pure quantum. However, in classical models such a mechanism is not only possible but inevitable under certain conditions. In this regard, it becomes possible to describe it in the same manner as in physics, using the methodology of

entangled states and quantum-mechanical rules of calculation of probabilities. A classical analogue of the EPR experiment described above is suggested in [2]. In this paper, a mechanism of replacement of the states of the system (a change of colors of some balls in the boxes) of one observer depending on the result of observation of the other is suggested (figure 2).

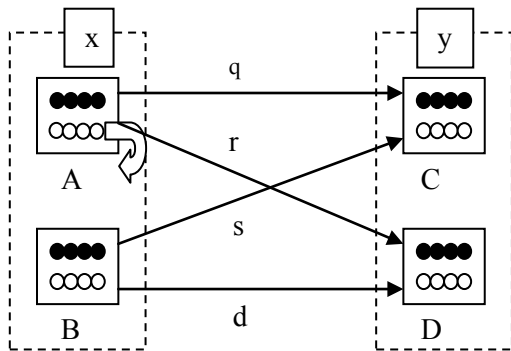

Figure 2 Scheme of a classical experiment with the possibility of changing the player's state after a question was asked, which reproduces the results of the EPR experiment.

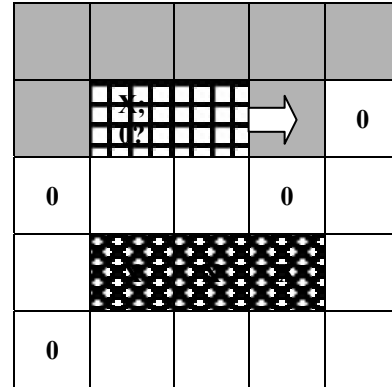

Figure 3. Field of the modified “sea battle” game. The overshadowed part corresponds to the superposition of possibilities.

This provides the total similarity to quantum probabilities of a physical model of the experiment. The authors of other works devoted to justification of the feasibility of quantum-mechanical description of macroscopic systems draw similar conclusions. For example, in [3] the macroscopic quantum games are considered in which one player (Alice) asks a question, after which the state of the second player (Bob) can change. Because of the symmetry of the matrix of payments in such a game it becomes possible to describe the state of Bob, as independent on Alice's questions. The simplification of the game description (and optimal strategies) occurs at the cost of the abandonment of the phase of state modification. However, this new description may involve the distribution law violation, which entails introducing the quantum rules of probability calculation.

To illustrate the described properties, let us also consider a modified game “The sea battle”. In this game each player has an additional opportunity to correct the initial disposition of ships on the game-playing field after a question is asked, but before an answer to it is given. Figure 3 shows a part of the game-playing field. The successful shots of a player are marked with “X”, while slip-ups are marked with “0”. The overshadowed squares show a possible location of the two-squared “ship”. According to the game rules, it should not touch the three-squared “ship” which has been already put out of action. If the next “shot” of the rival hits one of the squares of the ship, the player can move the ship to the neighboring squares and give an “honest” answer that the enemy has missed. This situation fully coincides with those described in the macroscopic games [3]. However, in contrast to them a player of the modified “sea battle” game begins to quickly realize that in this case **one might not draw the two-squared ship at all** and move it each time the preliminary hitting of the mark occurs. Instead, he describes a location of the two-squared ship by means of a range within which the latter can be still placed and narrow it, as needed, after each “shot” of the enemy. Actually, this simulates completely the property of the quantum-and-mechanic state, which is described by the superposition of alternatives as long as a selection of one of them takes place following the experiment.

The patterns of economic systems also come across the situations when a subject may choose a strategy without being guided by one or another of the supposed value of the price or by some assumed probable distribution of price but takes into account as a whole all the possible alternatives. However, here it may become possible to introduce a certain distribution of the “hidden parameters” to describe the experimental results. To ensure that no alternative pattern of the description on the basis of the “hidden parameters» exist, the Bell inequalities or their analogues should be satisfied.

3. Violation of Bell inequalities in the model of stock exchange

Almost any event in the economy can be viewed as a game situation, in which each of the subjects of the market has a lot of choices, and each of the combinations of a choice determines the payment of players. When selling any product or share one of the players offers his price while another player either agrees, or refuses. Thereby, the initial intention of the second player may change after receiving the proposal of the first one. In the process of such trade, an offer to buy a share at a price S_A can be regarded as a measure of the trader's state "in the direction of A". A consent or refuse (respectively, "+" and "-") can be considered as a result of the measurement of his state. Let us draw the analogy to the above EPR-experiment.

As above, we believe the measurement of A and D to be identical. A pair of measurements of the states for the particles moving away from each other corresponds to two mutually related purchase and sale transactions. If, for example, a trader agrees to buy a share at the price of S_A (the measurement result A is marked with "+"), then he will refuse to sell it at the same price until his state changes. This connection between his two answers is analogue to the measurements in one direction A of spins of the particles moving away from each other. The results of such measurements are always opposite. However, if one proposes the trader to sell the share at the greater price he may agree (the result of the measurement C is marked "-") or refuse (the result of the measurement C is marked "+"). Note, that, as well as in the EPR experiment, only two measurements can be carried out with each share (a pair of particles), following which the trader's state is changed. Thus, statistical regularities can be considered only for a set of "similarly prepared" traders. For the economic pattern this should mean that all traders possess similar information and apply one and the same mathematical methods and strategies. Otherwise, we will deal with a mixed state of the system, in which the traders are present who are "prepared" in the different manner. In the quantum-and-mechanical formalism such mixed states are described by the density matrix. In the classical model each trader is characterized by some value of the share price which he considers to be "fair".

The distance on a logarithmic scale of price is described by S_A/S_C . Suppose that the function describing a change of the subjective state of a trader after getting an offer is smooth. Then for each distances between the measurements the probability of receiving consent to buy (refusal to sell) a share at price S_C after buying at price S_A appears equal to the given number $\beta(S_A/S_C) \in (0;1)$. This parameter is characteristic of a subjunctive property of traders, i.e. a degree of trust to the result of the measurement, which, by convention, can be called a "measure of risks". The transaction is symmetrical with reference to sale; the logarithmic scale of prices is uniform. This allows us also to determine the probabilities of other paired tests. Here, the principle distinction of the economic model from that of the EPR experiment is another type of symmetry. In view of the evident failure of a pair of measurements (buying - selling) with a negative income, non-zero are only four of eight possible implementations of answering three questions. Namely, $\{\rho_{BAC}^{+++}, \rho_{BAC}^{+--}, \rho_{BAC}^{-+-}, \rho_{BAC}^{---}\}$. For these values, in particular, the relation: $(\rho_{BAC}^{+++} + \rho_{BAC}^{+--})/\rho_{BAC}^{+--} = \beta/(1-\beta)$; $\rho_{BAC}^{---}/\rho_{BAC}^{-+-} = \beta/(1-\beta)$ should be true. This implies that $\rho_{BAC}^{+++} + \rho_{BAC}^{-+-} = \rho_{BAC}^{+--}$. In view of symmetry, by the replacement of purchase by sale, we obtain a similar claim: $\rho_{BAC}^{---} + \rho_{BAC}^{-+-} = \rho_{BAC}^{+++}$. These equations are equivalent to the Bell inequalities in the EPR experiment. They can be fulfilled only if $\rho_{BAC}^{+--} + \rho_{BAC}^{-+-} = 0$. Since the probabilities of realization of the classical model cannot be negative, it is not feasible. Thus, in contrast to the EPR experiment, due to stronger restrictions on the possible implementation, we have the equality in place of the Bell inequalities. They are not true for any value $\beta \neq 0$.

Note that in the pattern under consideration the probability of a positive answer to the proposition to sell a share at some price is determined only by the last of trader's answers and the "distance" to the price of a new proposition. This corresponds to the quantum-and-mechanical collapse in the case of the precise measurement of some variable. The quantum system in this case totally "forgets" its pre-history. In a real economic situation this is not the case. Each of the transactions can change, to a

greater or lesser extent, the trader's view about the price of a share. If the measurements of the price occur quite frequently, each of them changes the state of the trader just slightly (in comparison with the whole set of measurements). The quantity of information obtained from each of such fuzzy measurements is determined by both their frequency, and properties (a degree of trust) of the trader. Therefore, in a real economic pattern, apart from the parameter $\beta(S_A/S_C) \in (0;1)$ for idealized measurements, one should consider the fuzziness parameter α of the share price measurement.

3. The dynamics of market shares as a weak continuous measurement

As one of the axioms adopted in the F. Black and M. Scholes model, the assumption that the dynamics of stock price $S(t)$ is described by the equation $dS/S = \mu \cdot dt + \sigma \cdot dW(t)$ is made, where μ and σ are the constants, $W(t)$ is the standard Wiener process. Here, an idealized model of a continuous market in which the stock price is objective and does not depend on the method and accuracy of the measurement. The above analysis has shown that this is not valid. In particular, the state of traders depends on the results of these measurements, whatever they may be. It cannot be described by the classical distribution $\rho(S)$ of the expected price in the general case. The results are, in their turn, determined by the state of traders. Thus, the random process $W(t)$, apart from the obvious external factors, includes a fatal random component associated with the measurement procedure and its influence on the state of traders. Similar processes are described by the formalism of the WCQM theory [4]. We used an information-based approach to the quantum Bayes theorem. It is based on the assumption that the observed change in the state of the quantum system under consideration is uniquely determined by the information received (including the vague information) [5]. In case of transition to the continuous description of dynamics of the observed quantum-and mechanical system, the fuzziness parameter α is actually determined by the final velocity of getting information about it. We consider a pattern of dynamics of a stock market and options assuming that this parameter is one and the same for the participants of tenders. In future it may be generalized to the arbitrary distribution of this parameter on a set of traders. In the case of modeling WCQM, the successive increments of the coordinates are no longer independent, unlike in the classical model. This is due to the fact that each of them changes the state of the system in line with the result, and the probability of the next increment depends on this state. They also do not represent the simple Markov chain as in the pattern of idealized measurements treated above.

The objective properties of continuous monitoring should not depend on the parameters of its description. In particular, the independence of the velocity of obtaining information on the choice of δt ensured the ratio $\langle |\delta S(\delta t)| \rangle \approx \alpha \sqrt{\delta t}$. Here, α is the constant process (imprecision of the measurement). Let us consider the module of the average random increments associated with the weak continuous measurement as uncertainty of "coordinates" obtained in the measurement of prices for time δt . Then, uncertainty of the "velocity" measured over the same period can be estimated as $\langle |\delta(dS/dt)| \rangle \approx \sqrt{2} \langle |\delta S(\delta t)| \rangle / \delta t \approx \sqrt{2} \alpha / \sqrt{\delta t}$. The product of uncertainties of "coordinates" and "velocity" is equal to $\sqrt{2} \alpha^2$ and is independent on the interval δt . It can be viewed as an analogue of the uncertainty principle in quantum mechanics. Parameter $\sqrt{2} \alpha^2$, in its turn, is related to the "measure of risk" β introduced earlier, and plays the role of the inverse masses (here, an analogue of Planck's constant is a dimensionless unit). As it increases, the amplitudes of quantum fluctuations in share price decrease and inertia of the state increase. Thus, in the model proposed, the dynamics of prices depend on the subjective factor along with external factors. In [6], in the framework of the WCQM, we obtained a quantum generalization of the F. Black and M. Scholes model for pricing options. We will further describe briefly the results obtained in this paper and discuss the possibilities of their practical application.

4. Modification of Classical Derivation of the Black-Scholes Formula

Let us comment the main assumptions used in classical derivation and their quantum interpretation. A priori set law of share price evolution $dS/dt = \mu S + \sigma S \cdot R(t)$, where $R(t)$ is the uncorrelated Gauss stochastic noise with zero main value transforms into a stochastic differential equation of market state dynamics at weak continuous measurement of “optimum” portfolio price.

$$\frac{d|\psi\rangle}{dt} = \left[-\frac{i}{\hbar} \hat{H} - k(\hat{A} - c)^2 \right] |\psi\rangle + \sqrt{2k}(\hat{A} - c) |\psi\rangle \frac{dw}{dt}, \quad (1)$$

where \hat{A} is the operator of the measured variable, $c = \langle \psi | \hat{A} | \psi \rangle$ is its mathematical expectation, \hat{H} is the Hamilton operator, the function of which we will discuss later, k is the parameter of fuzziness of measurement. In order to retain vector norm $|\psi\rangle$, $(\langle \psi | + \langle d\psi |) \cdot (|\psi\rangle + |d\psi\rangle) = \langle \psi | \psi \rangle$ it is sufficient to take $dw^2 = dt$ [4]. Let us note that we are considering an idealized model, in which the stochastic nature of price dynamics is caused by its constant fuzzy measurement, unlike the classical model, in which it is set a priori. Classical external influences, also causing price fluctuations, are not considered here, though formally they can be accounted as a random component of the Hamilton operator. The result of price measurement is considered its declaration at the current moment of trades. On the one hand, it contains information about the market status, as it is calculated in accordance with certain rules on the basis of submitted bids. On the other hand, it influences the market state, because on the basis of obtain information the traders submit their bids. As the velocity of obtaining the information is limited, in the model of continuous market, at decrease of the time step of discretization, the degree of uncertainty of the obtained results correspondingly increases. It is the main source of stochasticity in the model of continuous fuzzy measurement.

Absence of riskless arbitrating capabilities in the classical model of optimum portfolio price is set as $dV/V = rdt$. In the quantum model, the same condition must be satisfied for the mathematical price expectation of measured variable A . Otherwise, it will be possible to obtain a riskless gain (generally) by exchanging the corresponding securities for bonds. If the portfolio price is “measured”, the operator $\hat{A} \equiv \hat{V}$ corresponds to this procedure, influencing the state of the traders in accordance with their strategies and rules of price determination. Then we obtain the condition

$$\frac{d(\ln\langle V \rangle)}{dt} = \frac{1}{\langle V \rangle} \cdot \frac{d\langle V \rangle}{dt} = r, \text{ where } \langle \psi | \hat{V} | \psi \rangle = \langle V \rangle \quad (2)$$

Nevertheless, at the same time, it is possible to measure directly the speed of changing of the logarithmic price of the optimum portfolio (in practice in means conclusion of contracts with more complex structure, in which the payment is agreed depending on this parameter). In this case we obtain the ratio

$$\left\langle \frac{d \ln V}{dt} \right\rangle = r, \text{ and } \hat{A} \equiv \left(\frac{d \ln \hat{V}}{dt} \right) \quad (3)$$

Let us note that in the classical limit both these variants correspond to the same formula. However, the influence of the measurement on market state in the quantum model makes them different. In the present paper we limit ourselves to the consideration of the first variant.

In the classical model, the condition of optimality of portfolio means that its structure $V_{opt} = -f + (\partial f / \partial S)S$ ensures riskless condition at any related share and financial derivative price variations. With such a structure the risk turns into 0. However, in the quantum mechanical model the function $f(S, t)$ exists only for mathematical expectations of corresponding prices, which are calculated as average quantum mechanical values of results of fuzzy measurements. In this connection the risk value remains non-zero, and the portfolio structure is to minimize it.

As a measure of risk as one of the possibilities we use the value of dispersion of optimum portfolio price distribution (in the classical model it turns into 0). Then

$$\sigma_V = \langle V^2 \rangle - \langle V \rangle^2 = \langle (-f + kS)^2 \rangle - \langle (-f + kS) \rangle^2 \rightarrow \min \quad (4)$$

Assuming that it is the continuous function of parameter k , determining the portfolio structure, we can write down the optimality condition in the following form $\partial\sigma_V / \partial k = 0$. We can obtain from it:

$$k_{opt} = \frac{\langle f \cdot S \rangle - \langle f \rangle \cdot \langle S \rangle}{\sigma_S} \quad (5)$$

The same as in the classical model, the parameter k can depend on time. In the quantum mechanical model the ratio, determining the optimum portfolio structure, connects the corresponding operators, rather than the measured values of the variables. Due to incommutability of operators \hat{S} and \hat{f} :

$$\langle f \cdot S \rangle = [\langle \psi | \hat{f} \hat{S} | \psi \rangle + \langle \psi | \hat{S} \hat{f} | \psi \rangle] / 2 \quad (6)$$

5. The Black-Scholes Quantum Formula for a Specific Financial Derivative

For dynamics of average values of quantum variables with account of (1-5) we obtain:

$$\begin{cases} \frac{d\langle S \rangle}{dt} = \langle \psi | \hat{S} \hat{B} + \hat{B} \hat{S} | \psi \rangle + \langle \psi | \hat{S} \hat{C} + \hat{C} \hat{S} | \psi \rangle R(t) \\ \frac{d\langle f \rangle}{dt} = \langle \psi | \hat{f} \hat{B} + \hat{B} \hat{f} | \psi \rangle + \langle \psi | \hat{f} \hat{C} + \hat{C} \hat{f} | \psi \rangle R(t) + \left\langle \frac{\partial f}{\partial t} \right\rangle \end{cases}; \hat{B} = \left[-\frac{i}{\hbar} \hat{H} - k(V - c)^2 \right]; \hat{C} = \sqrt{2k}(V - c) \quad (7)$$

Excluding from them the random factor $R(t)$, we obtain a quantum analogy of the classical formula:

$$\frac{d\langle f \rangle}{dt} - \left\langle \frac{\partial f}{\partial t} \right\rangle - \langle \hat{f} \hat{B} + \hat{B} \hat{f} \rangle = \frac{\langle \hat{f} \hat{C} + \hat{C} \hat{f} \rangle}{\langle \hat{S} \hat{C} + \hat{C} \hat{S} \rangle} \cdot \left[\frac{d\langle S \rangle}{dt} - \langle \hat{S} \hat{B} + \hat{B} \hat{S} \rangle \right] \quad (8)$$

For further use it is necessary to substitute the expressions for operators \hat{B} and \hat{C} in the decisive form. At the next stage of the classical derivation, the condition of no-arbitrage is used, from which an additional connection of variables S and f is obtained. In the quantum case from (6) we obtain

$$\frac{d\langle f \rangle}{dt} - r\langle f \rangle = -k_{opt} \left(\frac{d\langle S \rangle}{dt} - r\langle S \rangle \right) \quad (9)$$

Despite the ‘‘similarity’’ of both formulas, unlike the classical analogue they include different proportionality coefficients between $d\langle f \rangle/dt$ and $d\langle S \rangle/dt$. They become identical and equal either in the classical limit $\partial f / \partial S$, or at a certain value $c = \langle \psi | \hat{A} | \psi \rangle$. In this case, the same as in the classical case, we can exclude the total time derivatives and obtain the following system:

$$\begin{cases} \frac{\langle \hat{f} \hat{C} + \hat{C} \hat{f} \rangle}{\langle \hat{S} \hat{C} + \hat{C} \hat{S} \rangle} = k_{opt} \\ \frac{r\langle f \rangle - \left\langle \frac{\partial f}{\partial t} \right\rangle - \langle \hat{f} \hat{B} \rangle}{\langle \hat{f} \hat{C} \rangle} = \frac{r\langle S \rangle - \langle \hat{S} \hat{B} \rangle}{\langle \hat{S} \hat{C} \rangle} \end{cases} \Rightarrow \begin{cases} \frac{\langle \hat{f} \hat{C} \rangle}{\langle \hat{f} \hat{S} \rangle - \langle \hat{f} \rangle \langle \hat{S} \rangle} = \frac{\langle \hat{S} \hat{C} \rangle}{\langle \hat{S}^2 \rangle - \langle \hat{S} \rangle^2} \\ \left\langle \frac{\partial f}{\partial t} \right\rangle + r\langle S \rangle \frac{\langle \hat{f} \hat{C} \rangle}{\langle \hat{S} \hat{C} \rangle} + \frac{\langle \hat{f} \hat{B} \rangle \langle \hat{S} \hat{C} \rangle - \langle \hat{S} \hat{B} \rangle \langle \hat{f} \hat{C} \rangle}{\langle \hat{S} \hat{C} \rangle} = r\langle f \rangle \end{cases} \quad (10)$$

This system is in fact a quantum analogue of the classical formula

$$\frac{\partial f}{\partial t} + \frac{1}{2} \sigma_s^2 S^2 \frac{\partial^2 f}{\partial S^2} + rS \frac{\partial f}{\partial S} = rf \quad (11)$$

The additional equation appears due to the fact that in our case the dynamics of price average value is not set a priori; it is the result of the procedure of its continuous measurement and influence of Hamiltonian. However, if we assume that not the price of optimum portfolio in one of the variants (2, 3), but the price of the share is measured, then, by substituting \hat{S} instead of \hat{V} in (7), we obtain an identity from the first condition, and from the second condition we obtain

$$\left\langle \frac{\partial f}{\partial t} \right\rangle + r \langle S \rangle \frac{\langle \hat{f} \hat{S} \rangle - \langle \hat{f} \rangle \langle \hat{S} \rangle}{\langle \hat{S}^2 \rangle - \langle \hat{S} \rangle^2} + \frac{\langle f \hat{B} \rangle \langle \hat{S} \hat{C} \rangle - \langle \hat{S} \hat{B} \rangle \langle f \hat{C} \rangle}{\langle \hat{S} \hat{C} \rangle} = r \langle f \rangle \quad (12)$$

7. Conclusions

The main reason for manifestation of quantum properties in macroscopic systems is a possibility to change the classical strategy after one or other question has been asked. This behavior is generalized to the state (strategy) of a player, which does not correspond to the classical state and is characterized by the whole set of alternatives. Here, the probability of realization of each of them is determined by the practicability of the answer and the questions asked, rather than by a mixed strategy, as with classical games. We have shown that in the simplest economic stock exchange patterns these properties manifest themselves inevitably. They result in violation of the analogues of the Bell inequalities. The extension of the idealized tender pattern to the pattern of continuous fuzzy quantum measurements has been made. It is shown that in so doing an analogue of the ambiguity principle is fulfilled for the trajectory of the share price. Within this pattern, the generalized formula of F. Black and M. Scholes model for pricing options is derived. The result of the solution of the obtained system with account of the boundary conditions connecting the share prices and financial derivative at the moment of closing the contract will be a functional dependency of operator \hat{f} on the operator \hat{S} and time t . However, for this purpose it is necessary to explicitly draw out the expression for the Hamiltonian. In physics, the form of Hamiltonian is determined by the general requirements connected with homogeneity and isotropy of space and the principle of relativity. We assume that in the same manner, in the economic models the form of Hamiltonian should also be determined by the type of symmetries set by the formal rules of trading. Our further research will be dedicated to the analysis of these properties and derivation of formulas for the Hamiltonian in various economic systems. In contrast to the classical analogue, the relation between the average stock price and option price depends on the rules of their measurement and is described by a system of two operator equations. Another key difference of the proposed model of the classical analogue is the emergence of a "memory effect" which is exponentially decaying with time. The characteristic decay time is similar to the decoherence time of the quantum state of the system observed and is determined by the measure of weakness of quantum continuous measurements. In turn, this parameter is related to the velocity of vague information on the price of shares and an economic parameter of the process, as volatility.

References

- [1] Melnyk S I, Tuluzov I G and Omelyanchouk A N 2006 Quantum Economics – Mysticism or Reality *Physics of Mind and Life, Cosmology and Astrophysics* **6**, 2 48-57.
- [2] Beltrametti L Bell Inequalities in Economics? *Quad. Dip. Econ. Pol.*, Univ. Siena (1994)
- [3] Grib A A and Parfionov G N 2005 Can a game be quantum? *Journ. of Mathematical Sciences* **125**, 2 173-184
- [4] Mensky MB 1993 *Continuous quantum measurement and path integrals* (Bristol and Philadelphia: IOP Publishing)
- [5] Neri F 2005 Quantum Bayesian methods and subsequent measurements *Phys. Rev. A* **72** 062306
- [6] Melnyk S I, and Tuluzov I G 2008 *EJTP* **5**, 18 95–104