

Halting problem undecidability and infinitely nested simulation

The x86utm operating system was created so that the halting problem could be examined concretely in the high level language of C. H is a function written in C that analyzes the x86 machine language execution trace of other functions written in C. H recognizes simple cases of infinite recursion and infinite loops. The conventional halting problem proof counter-example template is shown to simply be an input that does not halt.

H simulates its input with an x86 emulator until it determines that its input would never halt. As soon as H recognizes that its input would never halt it stops simulating this input and returns 0. For inputs that do halt H acts exactly as if it was an x86 emulator and simply runs its input to completion and then returns 1.

Halting computation: is any computation that eventually reaches its own final state.

Pathological Input to a halt decider is stipulated to mean any input that was defined to do the opposite of whatever its corresponding halt decider decides as Sipser describes:

Now we construct a new Turing machine D with H as a subroutine.
This new TM calls H to determine what M does when the input to M is its own description $\langle M \rangle$. Once D has determined this information, it does the opposite. (Sipser:1997:165)

Does D halts on its own machine description $\langle D \rangle$?

This question can only be correctly answered after the pathology has been removed. When a halt decider only acts as a pure simulator of its input until after its halt status decision is made there is no feedback loop of back channel communication between the halt decider and its input that can prevent a correct halt status decision. In this case the halt decider is only examining the behavior of the input. It ignores its own behavior.

The standard pseudo-code halting problem template "proved" that the halting problem could never be solved on the basis that neither value of true (halting) nor false (not halting) could be correctly returned from the halt decider to the confounding input.

```
procedure compute_g(i): // (wikipedia:Halting Problem)
  if f(i, i) == 0 then // adapted from (Strachey, C 1965)
    return 0 // originally written in CPL
  else // ancestor of the BCPL, B and C
    loop forever // programming languages
```

This problem is overcome on the basis that a simulating halt decider would abort the simulation of its input before ever returning any value to this input. It aborts the simulation of its input on the basis that its input specifies what is essentially infinite recursion (infinitely nested simulation) to any simulating halt decider.

Every input to a simulating halt decider that only stops running when its simulation is aborted unequivocally specifies a computation that never halts. When input to a simulating halt decider cannot possibly reach its final state while the simulating halt decider remains in pure simulation mode then this input never halts. **Based on this: $UTM(P,I) \equiv P(I)$**

Simulating partial halt decider H correctly decides that P(P) never halts (V1)

H analyzes the (currently updated) stored execution trace of its x86 emulation of P(P) after it simulates each instruction of input (P, P). As soon as a non-halting behavior pattern is matched H aborts the simulation of its input and decides that its input never reaches its final state.

The verifiably correct x86 execution trace of the simulation of the input to H(P,P) proves that this input cannot possibly reach its final state while H acts as a pure x86 emulator of this input. This unequivocally proves that H does correctly decide that its input never halts.

```
// Simplified Linz H (Linz:1990:319)
// Strachey(1965) CPL translated to C
```

```
void P(u32 x)
{
    if (H(x, x))
        HERE: goto HERE;
}

int main()
{
    output("Input_Halts = ", H((u32)P, (u32)P));
}
```

```
_P()
[0000c36] (01) 55          push ebp
[0000c37] (02) 8bec        mov ebp,esp
[0000c39] (03) 8b4508     mov eax,[ebp+08] // 2nd Param
[0000c3c] (01) 50          push eax
[0000c3d] (03) 8b4d08     mov ecx,[ebp+08] // 1st Param
[0000c40] (01) 51          push ecx
[0000c41] (05) e820fdffff call 00000966 // call H(P,P)
[0000c46] (03) 83c408     add esp,+08
[0000c49] (02) 85c0       test eax,eax
[0000c4b] (02) 7402       jz 0000c4f
[0000c4d] (02) ebfe       jmp 0000c4d
[0000c4f] (01) 5d         pop ebp
[0000c50] (01) c3         ret
Size in bytes:(0027) [0000c50]
```

```
_main()
[0000c56] (01) 55          push ebp
[0000c57] (02) 8bec        mov ebp,esp
[0000c59] (05) 68360c0000 push 0000c36 // push P
[0000c5e] (05) 68360c0000 push 0000c36 // push P
[0000c63] (05) e8fefcffff call 00000966 // call H(P,P)
[0000c68] (03) 83c408     add esp,+08
[0000c6b] (01) 50          push eax
[0000c6c] (05) 6857030000 push 0000c357
[0000c71] (05) e810f7ffff call 00000386
[0000c76] (03) 83c408     add esp,+08
[0000c79] (02) 33c0       xor eax,eax
[0000c7b] (01) 5d         pop ebp
[0000c7c] (01) c3         ret
Size in bytes:(0039) [0000c7c]
```

| machine address | stack address | stack data | machine code | assembly language |
|-----------------|---------------|------------|--------------|------------------------------|
| [0000c56] | [0010172a] | [00000000] | 55 | push ebp |
| [0000c57] | [0010172a] | [00000000] | 8bec | mov ebp,esp |
| [0000c59] | [00101726] | [0000c36] | 68360c000 | push 0000c36 // push P |
| [0000c5e] | [00101722] | [0000c36] | 68360c000 | push 0000c36 // push P |
| [0000c63] | [0010171e] | [0000c68] | e8fefcffff | call 00000966 // call H(P,P) |

Begin Local Halt Decider Simulation at Machine Address:c36

| | | | | |
|-----------|------------|------------|------------|------------------------------|
| [0000c36] | [002117ca] | [002117ce] | 55 | push ebp |
| [0000c37] | [002117ca] | [002117ce] | 8bec | mov ebp,esp |
| [0000c39] | [002117ca] | [002117ce] | 8b4508 | mov eax,[ebp+08] |
| [0000c3c] | [002117c6] | [0000c36] | 50 | push eax // push P |
| [0000c3d] | [002117c6] | [0000c36] | 8b4d08 | mov ecx,[ebp+08] |
| [0000c40] | [002117c2] | [0000c36] | 51 | push ecx // push P |
| [0000c41] | [002117be] | [0000c46] | e820fdffff | call 00000966 // call H(P,P) |

| | | | | |
|-----------|------------|------------|------------|------------------------------|
| [0000c36] | [0025c1f2] | [0025c1f6] | 55 | push ebp |
| [0000c37] | [0025c1f2] | [0025c1f6] | 8bec | mov ebp,esp |
| [0000c39] | [0025c1f2] | [0025c1f6] | 8b4508 | mov eax,[ebp+08] |
| [0000c3c] | [0025c1ee] | [0000c36] | 50 | push eax // push P |
| [0000c3d] | [0025c1ee] | [0000c36] | 8b4d08 | mov ecx,[ebp+08] |
| [0000c40] | [0025c1ea] | [0000c36] | 51 | push ecx // push P |
| [0000c41] | [0025c1e6] | [0000c46] | e820fdffff | call 00000966 // call H(P,P) |

Local Halt Decider: Infinite Recursion Detected Simulation Stopped

In the above 14 instructions of the simulation of P(P) we can see that the first 7 instructions of P are repeated. The end of this sequence of 7 instructions P calls H with its own machine address as the parameters to H(P,P). Because H only examines the behavior of its inputs and ignores its own behavior when H(P,P) is called we only see the first instruction of P being simulated.

Anyone knowing the x86 language well enough can see that none of these 7 simulated instructions of P have any escape from their infinitely repeating behavior pattern. When H recognizes this infinitely repeating pattern it aborts its simulation of P(P) and reports that its input: (P,P) never reaches its final state of 0xc50.

| | | | | |
|-----------|------------|------------|------------|---------------|
| [0000c68] | [0010172a] | [00000000] | 83c408 | add esp,+08 |
| [0000c6b] | [00101726] | [00000000] | 50 | push eax |
| [0000c6c] | [00101722] | [00000357] | 685703000 | push 00000357 |
| [0000c71] | [00101722] | [00000357] | e810f7ffff | call 00000386 |

Input_Halts = 0

| | | | | |
|-----------|------------|------------|--------|-------------|
| [0000c76] | [0010172a] | [00000000] | 83c408 | add esp,+08 |
| [0000c79] | [0010172a] | [00000000] | 33c0 | xor eax,eax |
| [0000c7b] | [0010172e] | [00100000] | 5d | pop ebp |
| [0000c7c] | [00101732] | [00000068] | c3 | ret |

Number_of_User_Instructions(27)

Number of Instructions Executed(23721)

Simulating partial halt decider H correctly decides that P(P) never halts (V2)

```
// Simplified Linz A (Linz:1990:319)
// Strachey(1965) CPL translated to C
```

```
void P(u32 x)
{
    if (H(x, x))
        HERE: goto HERE;
}
```

```
int main()
{
    P((u32)P);
}
```

```
_P()
[0000c25] (01) 55          push ebp
[0000c26] (02) 8bec         mov ebp,esp
[0000c28] (03) 8b4508      mov eax,[ebp+08]
[0000c2b] (01) 50          push eax // 2nd Param
[0000c2c] (03) 8b4d08      mov ecx,[ebp+08]
[0000c2f] (01) 51          push ecx // 1st Param
[0000c30] (05) e820fdffff call 00000955 // call H
[0000c35] (03) 83c408      add esp,+08
[0000c38] (02) 85c0         test eax,eax
[0000c3a] (02) 7402         jz 0000c3e
[0000c3c] (02) ebfe         jmp 0000c3c
[0000c3e] (01) 5d          pop ebp
[0000c3f] (01) c3          ret
Size in bytes:(0027) [0000c3f]
```

```
_main()
[0000c45] (01) 55          push ebp
[0000c46] (02) 8bec         mov ebp,esp
[0000c48] (05) 68250c0000 push 0000c25 // push P
[0000c4d] (05) e8d3ffff call 0000c25 // call P(P)
[0000c52] (03) 83c404      add esp,+04
[0000c55] (02) 33c0         xor eax,eax
[0000c57] (01) 5d          pop ebp
[0000c58] (01) c3          ret
Size in bytes:(0020) [0000c58]
```

| machine address | stack address | stack data | machine code | assembly language |
|-----------------|---------------|------------|--------------|--|
| [0000c45] | [001016d6] | [00000000] | 55 | push ebp |
| [0000c46] | [001016d6] | [00000000] | 8bec | mov ebp,esp |
| [0000c48] | [001016d2] | [0000c25] | 68250c0000 | push 0000c25 // push P |
| [0000c4d] | [001016ce] | [0000c52] | e8d3ffff | call 0000c25 // call P ₀ (P) |
| [0000c25] | [001016ca] | [001016d6] | 55 | push ebp // P ₀ begins |
| [0000c26] | [001016ca] | [001016d6] | 8bec | mov ebp,esp |
| [0000c28] | [001016ca] | [001016d6] | 8b4508 | mov eax,[ebp+08] |
| [0000c2b] | [001016c6] | [0000c25] | 50 | push eax // push P |
| [0000c2c] | [001016c6] | [0000c25] | 8b4d08 | mov ecx,[ebp+08] |
| [0000c2f] | [001016c2] | [0000c25] | 51 | push ecx // push P |
| [0000c30] | [001016be] | [0000c35] | e820fdffff | call 00000955 // call H ₀ (P ₁ ,P ₁) |

```

Begin Local Halt Decider Simulation at Machine Address:c25
[0000c25][00211776][0021177a] 55      push ebp      // P1 begins
[0000c26][00211776][0021177a] 8bec      mov ebp,esp
[0000c28][00211776][0021177a] 8b4508    mov eax,[ebp+08]
[0000c2b][00211772][0000c25] 50      push eax      // push P
[0000c2c][00211772][0000c25] 8b4d08    mov ecx,[ebp+08]
[0000c2f][0021176e][0000c25] 51      push ecx      // push P
[0000c30][0021176a][0000c35] e820fdffff call 00000955 // call H1(P2,P2)

[0000c25][0025c19e][0025c1a2] 55      push ebp      // P2 begins
[0000c26][0025c19e][0025c1a2] 8bec      mov ebp,esp
[0000c28][0025c19e][0025c1a2] 8b4508    mov eax,[ebp+08]
[0000c2b][0025c19a][0000c25] 50      push eax      // push P
[0000c2c][0025c19a][0000c25] 8b4d08    mov ecx,[ebp+08]
[0000c2f][0025c196][0000c25] 51      push ecx      // push P
[0000c30][0025c192][0000c35] e820fdffff call 00000955 // call H2(P3,P3)
Local Halt Decider: Infinite Recursion Detected Simulation Stopped

```

In the above computation (zero based addressing) H_0 aborts P_1
No $P(P)$ ever stops running unless H_0 aborts its simulation of P_1

The subscripts indicate that a new process context has been created to simulate the virtual machine. It has its own RAM, stack and registers.

```

[0000c35][001016ca][001016d6] 83c408    add esp,+08
[0000c38][001016ca][001016d6] 85c0      test eax,eax
[0000c3a][001016ca][001016d6] 7402      jz 0000c3e
[0000c3e][001016ce][0000c52] 5d      pop ebp
[0000c3f][001016d2][0000c25] c3      ret
[0000c52][001016d6][00000000] 83c404    add esp,+04
[0000c55][001016d6][00000000] 33c0      xor eax,eax
[0000c57][001016da][00100000] 5d      pop ebp
[0000c58][001016de][00000084] c3      ret
Number_of_User_Instructions(34)
Number of Instructions Executed(23729)

```

- (1) H does perform a pure simulation of its input until after it makes its halt status decision.
- (2) It can be verified that this is a pure simulation on the basis that the execution trace does what the x86 source-code of P specifies.
- (3) Because there are no control flow instructions in the execution trace that can possibly escape the infinite recursion the execution trace proves that a pure simulation of the above input cannot possibly ever reach its final state.
- (4) Therefore H was correct when it decided that its input never halts.

Pathological self-reference(Olcott 2004) decider [Defeating Rice's Theorem]

Rice's theorem: In computability theory, Rice's theorem states that all non-trivial, semantic properties of programs are undecidable. (Wikipedia)

```
int Simulate(u32 P, u32 I)
{
  ((int(*) (int))P)(I);
  return 1;
}

// H and H2 are partial halt deciders
u32 PSR_Decider(u32 P, u32 I)
{
  u32 Input_Halts1 = H((u32)P, (u32)I);
  u32 Input_Halts2 = H2((u32)Simulate, (u32)P, (u32)I);
  Output("Input_Halts1 = ", Input_Halts1);
  Output("Input_Halts2 = ", Input_Halts2);
  if (Input_Halts1 != Input_Halts2)
    return 1;
  return 0;
}

void P(u32 x)
{
  if (H(x, x))
    HERE: goto HERE;
}

int main()
{
  Output("PSR_Decider = ", PSR_Decider((u32)P, (u32)P));
}
```

```
_Simulate()
[0000c22] (01) 55          push ebp
[0000c23] (02) 8bec        mov ebp,esp
[0000c25] (03) 8b450c     mov eax,[ebp+0c]
[0000c28] (01) 50          push eax
[0000c29] (03) ff5508     call dword [ebp+08]
[0000c2c] (03) 83c404     add esp,+04
[0000c2f] (05) b801000000 mov eax,00000001
[0000c34] (01) 5d          pop ebp
[0000c35] (01) c3          ret
Size in bytes:(0020) [0000c35]
```

```
_PSR_Decider()
[0000c42] (01) 55          push ebp
[0000c43] (02) 8bec        mov ebp,esp
[0000c45] (03) 83ec08     sub esp,+08
[0000c48] (03) 8b450c     mov eax,[ebp+0c]
[0000c4b] (01) 50          push eax
[0000c4c] (03) 8b4d08     mov ecx,[ebp+08]
[0000c4f] (01) 51          push ecx
[0000c50] (05) e86dfeffff call 0000ac2 // call H
[0000c55] (03) 83c408     add esp,+08
[0000c58] (03) 8945fc     mov [ebp-04],eax
[0000c5b] (03) 8b550c     mov edx,[ebp+0c]
[0000c5e] (01) 52          push edx
[0000c5f] (03) 8b4508     mov eax,[ebp+08]
[0000c62] (01) 50          push eax
[0000c63] (05) 68220c0000 push 0000c22
[0000c68] (05) e875fdffff call 000009e2 // call H2
[0000c6d] (03) 83c40c     add esp,+0c
[0000c70] (03) 8945f8     mov [ebp-08],eax
```

```

[0000c73] (03) 8b4dfc    mov ecx,[ebp-04]
[0000c76] (01) 51        push ecx
[0000c77] (05) 6823030000 push 00000323
[0000c7c] (05) e8f1f6ffff call 00000372
[0000c81] (03) 83c408    add esp,+08
[0000c84] (03) 8b55f8    mov edx,[ebp-08]
[0000c87] (01) 52        push edx
[0000c88] (05) 6833030000 push 00000333
[0000c8d] (05) e8e0f6ffff call 00000372
[0000c92] (03) 83c408    add esp,+08
[0000c95] (03) 8b45fc    mov eax,[ebp-04]
[0000c98] (03) 3b45f8    cmp eax,[ebp-08]
[0000c9b] (02) 7407     jz 0000ca4
[0000c9d] (05) b801000000 mov eax,00000001
[0000ca2] (02) eb02     jmp 0000ca6
[0000ca4] (02) 33c0     xor eax,eax
[0000ca6] (02) 8be5     mov esp,ebp
[0000ca8] (01) 5d        pop ebp
[0000ca9] (01) c3        ret
Size in bytes:(0104) [0000ca9]

```

```

_P()
[0000cb2] (01) 55        push ebp
[0000cb3] (02) 8bec     mov ebp,esp
[0000cb5] (03) 8b4508    mov eax,[ebp+08]
[0000cb8] (01) 50        push eax
[0000cb9] (03) 8b4d08    mov ecx,[ebp+08]
[0000cbc] (01) 51        push ecx
[0000cbd] (05) e800feffff call 0000ac2 // call H
[0000cc2] (03) 83c408    add esp,+08
[0000cc5] (02) 85c0     test eax,eax
[0000cc7] (02) 7402     jz 0000ccb
[0000cc9] (02) ebfe     jmp 0000cc9
[0000ccb] (01) 5d        pop ebp
[0000ccc] (01) c3        ret
Size in bytes:(0027) [0000ccc]

```

```

_main()
[0000cd2] (01) 55        push ebp
[0000cd3] (02) 8bec     mov ebp,esp
[0000cd5] (05) 68b20c0000 push 0000cb2 // push P
[0000cda] (05) 68b20c0000 push 0000cb2 // push P
[0000cdf] (05) e85effffff call 0000c42 // PSR_Decider(P,P)
[0000ce4] (03) 83c408    add esp,+08
[0000ce7] (01) 50        push eax
[0000ce8] (05) 6843030000 push 0000343
[0000ced] (05) e880f6ffff call 0000372 // call output()
[0000cf2] (03) 83c408    add esp,+08
[0000cf5] (02) 33c0     xor eax,eax
[0000cf7] (01) 5d        pop ebp
[0000cf8] (01) c3        ret
Size in bytes:(0039) [0000cf8]

```

| machine address | stack address | stack data | machine code | assembly language |
|-----------------|---------------|------------|--------------|----------------------------------|
| [0000cd2] | [001017ed] | [00000000] | 55 | push ebp |
| [0000cd3] | [001017ed] | [00000000] | 8bec | mov ebp,esp |
| [0000cd5] | [001017e9] | [0000cb2] | 68b20c0000 | push 0000cb2 // push P |
| [0000cda] | [001017e5] | [0000cb2] | 68b20c0000 | push 0000cb2 // push P |
| [0000cdf] | [001017e1] | [0000ce4] | e85effffff | call 0000c42 // PSR_Decider(P,P) |
| [0000c42] | [001017dd] | [001017ed] | 55 | push ebp |
| [0000c43] | [001017dd] | [001017ed] | 8bec | mov ebp,esp |
| [0000c45] | [001017d5] | [90909090] | 83ec08 | sub esp,+08 |
| [0000c48] | [001017d5] | [90909090] | 8b450c | mov eax,[ebp+0c] |

```

[0000c4b][001017d1][0000cb2] 50      push eax      // push P
[0000c4c][001017d1][0000cb2] 8b4d08     mov ecx,[ebp+08]
[0000c4f][001017cd][0000cb2] 51      push ecx      // push P
[0000c50][001017c9][0000c55] e86dfeffff  call 0000ac2 // H(P,P)

```

Begin Local Halt Decider Simulation at Machine Address:cb2

```

[0000cb2][0021188d][00211891] 55      push ebp
[0000cb3][0021188d][00211891] 8bec     mov ebp,esp
[0000cb5][0021188d][00211891] 8b4508     mov eax,[ebp+08]
[0000cb8][00211889][0000cb2] 50      push eax      // push P
[0000cb9][00211889][0000cb2] 8b4d08     mov ecx,[ebp+08]
[0000cbc][00211885][0000cb2] 51      push ecx      // push P
[0000cbd][00211881][0000cc2] e800feffff  call 0000ac2 // H(P,P)
[0000cb2][0025c2b5][0025c2b9] 55      push ebp
[0000cb3][0025c2b5][0025c2b9] 8bec     mov ebp,esp
[0000cb5][0025c2b5][0025c2b9] 8b4508     mov eax,[ebp+08]
[0000cb8][0025c2b1][0000cb2] 50      push eax      // push P
[0000cb9][0025c2b1][0000cb2] 8b4d08     mov ecx,[ebp+08]
[0000cbc][0025c2ad][0000cb2] 51      push ecx      // push P
[0000cbd][0025c2a9][0000cc2] e800feffff  call 0000ac2 // H(P,P)

```

Local Halt Decider: Infinite Recursion Detected Simulation Stopped

```

[0000c55][001017d5][90909090] 83c408     add esp,+08
[0000c58][001017d5][90909090] 8945fc     mov [ebp-04],eax
[0000c5b][001017d5][90909090] 8b550c     mov edx,[ebp+0c]
[0000c5e][001017d1][0000cb2] 52      push edx
[0000c5f][001017d1][0000cb2] 8b4508     mov eax,[ebp+08]
[0000c62][001017cd][0000cb2] 50      push eax
[0000c63][001017c9][0000c22] 68220c0000  push 0000c22
[0000c68][001017c5][0000c6d] e875fdffff  call 000009e2

```

Begin Local Halt Decider Simulation at Machine Address:c22

```

[0000c22][0026c351][0026c355] 55      push ebp
[0000c23][0026c351][0026c355] 8bec     mov ebp,esp
[0000c25][0026c351][0026c355] 8b450c     mov eax,[ebp+0c]
[0000c28][0026c34d][0000cb2] 50      push eax

```

Calling:_P()

Decode_Control_Flow_Instruction([00000008][0026c351][0000cb2])

```

[0000c29][0026c349][0000c2c] ff5508     call dword [ebp+08]
[0000cb2][0026c345][0026c351] 55      push ebp
[0000cb3][0026c345][0026c351] 8bec     mov ebp,esp
[0000cb5][0026c345][0026c351] 8b4508     mov eax,[ebp+08]
[0000cb8][0026c341][0000cb2] 50      push eax      // push P
[0000cb9][0026c341][0000cb2] 8b4d08     mov ecx,[ebp+08]
[0000cbc][0026c33d][0000cb2] 51      push ecx      // push P
[0000cbd][0026c339][0000cc2] e800feffff  call 0000ac2 // H(P,P)

```

Begin Local Halt Decider Simulation at Machine Address:cb2

```

[0000cb2][002b6d7d][002b6d81] 55      push ebp
[0000cb3][002b6d7d][002b6d81] 8bec     mov ebp,esp
[0000cb5][002b6d7d][002b6d81] 8b4508     mov eax,[ebp+08]
[0000cb8][002b6d79][0000cb2] 50      push eax      // push P
[0000cb9][002b6d79][0000cb2] 8b4d08     mov ecx,[ebp+08]
[0000cbc][002b6d75][0000cb2] 51      push ecx      // push P
[0000cbd][002b6d71][0000cc2] e800feffff  call 0000ac2 // H(P,P)
[0000cb2][003017a5][003017a9] 55      push ebp
[0000cb3][003017a5][003017a9] 8bec     mov ebp,esp
[0000cb5][003017a5][003017a9] 8b4508     mov eax,[ebp+08]
[0000cb8][003017a1][0000cb2] 50      push eax      // push P
[0000cb9][003017a1][0000cb2] 8b4d08     mov ecx,[ebp+08]
[0000cbc][0030179d][0000cb2] 51      push ecx      // push P
[0000cbd][00301799][0000cc2] e800feffff  call 0000ac2 // H(P,P)

```

Local Halt Decider: Infinite Recursion Detected Simulation Stopped

```

[0000cc2][0026c345][0026c351] 83c408    add esp,+08
[0000cc5][0026c345][0026c351] 85c0     test eax,eax
[0000cc7][0026c345][0026c351] 7402     jz 0000ccb
[0000ccb][0026c349][0000c2c] 5d       pop ebp
[0000ccc][0026c34d][0000cb2] c3       ret
[0000c2c][0026c351][0026c355] 83c404   add esp,+04
[0000c2f][0026c351][0026c355] b801000000 mov eax,00000001
[0000c34][0026c355][0000aa3] 5d       pop ebp
[0000c35][0026c359][0000cb2] c3       ret
[0000c6d][001017d5][90909090] 83c40c   add esp,+0c
[0000c70][001017d5][00000001] 8945f8   mov [ebp-08],eax
[0000c73][001017d5][00000001] 8b4dfc   mov ecx,[ebp-04]
[0000c76][001017d1][00000000] 51       push ecx
[0000c77][001017cd][00000323] 6823030000 push 00000323
[0000c7c][001017cd][00000323] e8f1f6ffff call 00000372 // call output()
Input_Halts1 = 0
[0000c81][001017d5][00000001] 83c408   add esp,+08
[0000c84][001017d5][00000001] 8b55f8   mov edx,[ebp-08]
[0000c87][001017d1][00000001] 52       push edx
[0000c88][001017cd][00000333] 6833030000 push 00000333
[0000c8d][001017cd][00000333] e8e0f6ffff call 00000372 // call output()
Input_Halts2 = 1
[0000c92][001017d5][00000001] 83c408   add esp,+08
[0000c95][001017d5][00000001] 8b45fc   mov eax,[ebp-04]
[0000c98][001017d5][00000001] 3b45f8   cmp eax,[ebp-08]
[0000c9b][001017d5][00000001] 7407     jz 0000ca4
[0000c9d][001017d5][00000001] b801000000 mov eax,00000001
[0000ca2][001017d5][00000001] eb02     jmp 0000ca6
[0000ca6][001017dd][001017ed] 8be5     mov esp,ebp
[0000ca8][001017e1][0000ce4] 5d       pop ebp
[0000ca9][001017e5][0000cb2] c3       ret
[0000ce4][001017ed][00000000] 83c408   add esp,+08
[0000ce7][001017e9][00000001] 50       push eax
[0000ce8][001017e5][00000343] 6843030000 push 00000343
[0000ced][001017e5][00000343] e880f6ffff call 00000372 // call output()
PSR_Decider = 1
[0000cf2][001017ed][00000000] 83c408   add esp,+08
[0000cf5][001017ed][00000000] 33c0     xor eax,eax
[0000cf7][001017f1][00100000] 5d       pop ebp
[0000cf8][001017f5][00000184] c3       ret
Number_of_User_Instructions(98)
Number of Instructions Executed(652216)

```

When a self-contradictory input to a simulating partial halt decider derives what appears to be a contradictory output u_{32} $PSR_Decider(u_{32} P, u_{32} I)$ has the intelligence divide all inputs that are in the domain of this simulating partial halt decider into those having the pathological self-reference(Olcott 2004) error and those that do not.

The only inputs that are outside of the domain of the simulating partial halt decider are inputs that have more complex non-halting behavior than it has been defined to recognize.

Simulating partial halt decider H correctly decides that Infinite_Loop() never halts

```

void Infinite_Loop()
{
    HERE: goto HERE;
}

int main()
{
    u32 Input_would_Halt2 = H((u32)Infinite_Loop, (u32)Infinite_Loop);
    Output("Input_would_Halt2 = ", Input_would_Halt2);
}

```

```

_Infinite_Loop()
[0000ab0] (01) 55          push ebp
[0000ab1] (02) 8bec        mov ebp,esp
[0000ab3] (02) ebfe        jmp 0000ab3
[0000ab5] (01) 5d          pop ebp
[0000ab6] (01) c3          ret
Size in bytes:(0007) [0000ab6]

```

```

_main()
[0000c00] (01) 55          push ebp
[0000c01] (02) 8bec        mov ebp,esp
[0000c03] (01) 51          push ecx
[0000c04] (05) 68b00a0000  push 0000ab0
[0000c09] (05) 68b00a0000  push 0000ab0
[0000c0e] (05) e84dfdffff  call 0000960
[0000c13] (03) 83c408      add esp,+08
[0000c16] (03) 8945fc      mov [ebp-04],eax
[0000c19] (03) 8b45fc      mov eax,[ebp-04]
[0000c1c] (01) 50          push eax
[0000c1d] (05) 684b030000  push 000034b
[0000c22] (05) e859f7ffff  call 0000380
[0000c27] (03) 83c408      add esp,+08
[0000c2a] (02) 33c0        xor eax,eax
[0000c2c] (02) 8be5        mov esp,ebp
[0000c2e] (01) 5d          pop ebp
[0000c2f] (01) c3          ret
Size in bytes:(0048) [0000c2f]

```

Execution Trace of H(Infinite_Loop, Infinite_Loop)

| machine address | stack address | stack data | machine code | assembly language |
|-----------------|---------------|------------|--------------|-------------------|
| [0000c00] | [00101693] | [00000000] | 55 | push ebp |
| [0000c01] | [00101693] | [00000000] | 8bec | mov ebp,esp |
| [0000c03] | [0010168f] | [00000000] | 51 | push ecx |
| [0000c04] | [0010168b] | [00000ab0] | 68b00a0000 | push 0000ab0 |
| [0000c09] | [00101687] | [00000ab0] | 68b00a0000 | push 0000ab0 |
| [0000c0e] | [00101683] | [00000c13] | e84dfdffff | call 0000960 |

Begin Local Halt Decider Simulation at Machine Address:ab0

| | | | | |
|-----------|------------|------------|------|-------------|
| [0000ab0] | [00211733] | [00211737] | 55 | push ebp |
| [0000ab1] | [00211733] | [00211737] | 8bec | mov ebp,esp |
| [0000ab3] | [00211733] | [00211737] | ebfe | jmp 0000ab3 |
| [0000ab3] | [00211733] | [00211737] | ebfe | jmp 0000ab3 |

Local Halt Decider: Infinite Loop Detected Simulation Stopped

```

[0000c13][0010168f][00000000] 83c408    add esp,+08
[0000c16][0010168f][00000000] 8945fc    mov [ebp-04],eax
[0000c19][0010168f][00000000] 8b45fc    mov eax,[ebp-04]
[0000c1c][0010168b][00000000] 50        push eax
[0000c1d][00101687][0000034b] 684b030000 push 0000034b
[0000c22][00101687][0000034b] e859f7ffff call 00000380
Input_Would_Halt2 = 0
[0000c27][0010168f][00000000] 83c408    add esp,+08
[0000c2a][0010168f][00000000] 33c0      xor eax,eax
[0000c2c][00101693][00000000] 8be5      mov esp,ebp
[0000c2e][00101697][00100000] 5d        pop ebp
[0000c2f][0010169b][00000050] c3        ret
Number_of_User_Instructions(21)
Number of Instructions Executed(640)

```

Simulating partial halt decider H decides that Infinite_Recursion() never halts

```

void Infinite_Recursion(u32 N)
{
    Infinite_Recursion(N);
}

int main()
{
    u32 Input_Halts = H((u32)Infinite_Recursion, 3);
    Output("Input_Halts = ", Input_Halts);
}

```

```

_Infinite_Recursion()
[0000ac6] (01) 55          push ebp
[0000ac7] (02) 8bec         mov ebp,esp
[0000ac9] (03) 8b4508      mov eax,[ebp+08]
[0000acc] (01) 50          push eax
[0000acd] (05) e8f4ffffff  call 0000ac6
[0000ad2] (03) 83c404      add esp,+04
[0000ad5] (01) 5d          pop ebp
[0000ad6] (01) c3          ret
Size in bytes:(0017) [0000ad6]

```

```

_main()
[0000c46] (01) 55          push ebp
[0000c47] (02) 8bec         mov ebp,esp
[0000c49] (01) 51          push ecx
[0000c4a] (02) 6a03         push +03
[0000c4c] (05) 68c60a0000  push 0000ac6
[0000c51] (05) e810fdffff  call 0000966
[0000c56] (03) 83c408      add esp,+08
[0000c59] (03) 8945fc      mov [ebp-04],eax
[0000c5c] (03) 8b45fc      mov eax,[ebp-04]
[0000c5f] (01) 50          push eax
[0000c60] (05) 6857030000  push 0000357
[0000c65] (05) e81cf7ffff  call 0000386
[0000c6a] (03) 83c408      add esp,+08
[0000c6d] (02) 33c0         xor eax,eax
[0000c6f] (02) 8be5         mov esp,ebp
[0000c71] (01) 5d          pop ebp
[0000c72] (01) c3          ret
Size in bytes:(0045) [0000c72]

```

Execution Trace of H(Infinite_Recursion, 3)

| machine address | stack address | stack data | machine code | assembly language |
|-----------------|---------------|------------|--------------|-------------------|
| [0000c46] | [001016fa] | [00000000] | 55 | push ebp |
| [0000c47] | [001016fa] | [00000000] | 8bec | mov ebp,esp |
| [0000c49] | [001016f6] | [00000000] | 51 | push ecx |
| [0000c4a] | [001016f2] | [00000003] | 6a03 | push +03 |
| [0000c4c] | [001016ee] | [00000ac6] | 68c60a0000 | push 0000ac6 |
| [0000c51] | [001016ea] | [00000c56] | e810fdffff | call 0000966 |

```

Begin Local Halt Decider Simulation at Machine Address:ac6
[0000ac6][0021179a][0021179e] 55      push ebp
[0000ac7][0021179a][0021179e] 8bec   mov ebp,esp
[0000ac9][0021179a][0021179e] 8b4508 mov eax,[ebp+08]
[0000acc][00211796][00000003] 50     push eax
[0000acd][00211792][00000ad2] e8f4ffff call 0000ac6
[0000ac6][0021179a][0021179a] 55     push ebp
[0000ac7][0021178e][0021179a] 8bec   mov ebp,esp
[0000ac9][0021178e][0021179a] 8b4508 mov eax,[ebp+08]
[0000acc][0021178a][00000003] 50     push eax
[0000acd][00211786][00000ad2] e8f4ffff call 0000ac6
Local Halt Decider: Infinite Recursion Detected Simulation Stopped

```

_Infinite_Recursion() calls itself recursively with the same input. It has no escape from this infinite recursion. H recognizes this infinite behavior pattern, aborts its simulation of _Infinite_Recursion() and reports that this input never halts.

```

[0000c56][001016f6][00000000] 83c408 add esp,+08
[0000c59][001016f6][00000000] 8945fc mov [ebp-04],eax
[0000c5c][001016f6][00000000] 8b45fc mov eax,[ebp-04]
[0000c5f][001016f2][00000000] 50     push eax
[0000c60][001016ee][00000357] 6857030000 push 00000357
[0000c65][001016ee][00000357] e81cf7ffff call 00000386
Input_Halts = 0
[0000c6a][001016f6][00000000] 83c408 add esp,+08
[0000c6d][001016f6][00000000] 33c0   xor eax,eax
[0000c6f][001016fa][00000000] 8be5   mov esp,ebp
[0000c71][001016fe][00100000] 5d     pop ebp
[0000c72][00101702][00000068] c3     ret
Number_of_User_Instructions(27)
Number of Instructions Executed(1240)

```

Infinite recursion detection criteria:

If the execution trace of function X() called by function Y() shows:

- (1) Function X() is called twice in sequence from the same machine address of Y().
- (2) With the same parameters to X().
- (3) With no conditional branch or indexed jump instructions in Y().
- (4) With no function call returns from X().

then the function call from Y() to X() is infinitely recursive unless X() stops it.

Strachey's Impossible Program

To the Editor,
The Computer Journal.

An impossible program

Sir,

A well-known piece of folk-lore among programmers holds that it is impossible to write a program which can examine any other program and tell, in every case, if it will terminate or get into a closed loop when it is run. I have never actually seen a proof of this in print, and though Alan Turing once gave me a verbal proof (in a railway carriage on the way to a Conference at the NPL in 1953), I unfortunately and promptly forgot the details. This left me with an uneasy feeling that the proof must be long or complicated, but in fact it is so short and simple that it may be of interest to casual readers. The version below uses CPL, but not in any essential way.

Suppose $T[R]$ is a Boolean function taking a routine (or program) R with no formal or free variables as its argument and that for all R , $T[R]$ — True if R terminates if run and that $T[R] = \text{False}$ if R does not terminate. Consider the routine P defined as follows

```
rec routine P
  §L:if T[P] go to L
  Return §
```

If $T[P] = \text{True}$ the routine P will loop, and it will only terminate if $T[P] = \text{False}$. In each case $T[P]$ has exactly the wrong value, and this contradiction shows that the function T cannot exist.

Yours faithfully,
C. STRACHEY.

Churchill College,
Cambridge.

Strachey, C 1965. An impossible program The Computer Journal, Volume 7, Issue 4, January 1965, Page 313, <https://doi.org/10.1093/comjnl/7.4.313>

Peter Linz \hat{H} applied to the Turing machine description of itself: $\langle \hat{H} \rangle$

The following simplifies the syntax for the definition of the Linz Turing machine \hat{H} , it is now a single machine with a single start state. The halt decider is embedded at state $\hat{H}.qx$.

$\hat{H}.q_0 wM \vdash^* \hat{H}.qx wM wM \vdash^* \hat{H}.qy \infty$
if M applied to wM halts, and

$\hat{H}.q_0 wM \vdash^* \hat{H}.qx wM wM \vdash^* \hat{H}.qn$
if M applied to wM does not halt

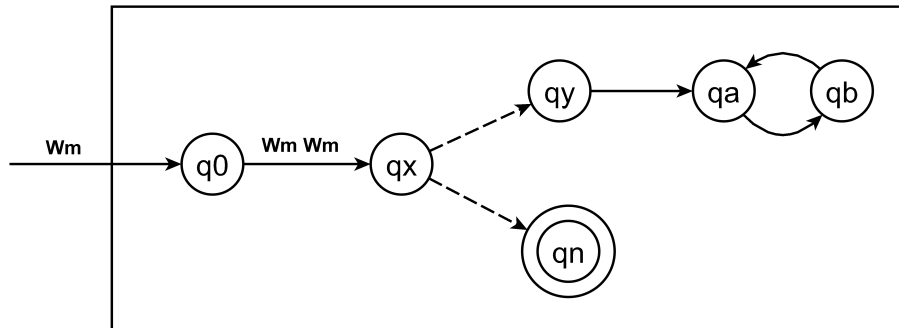

Figure 12.3 Turing Machine \hat{H}

To provide a sketch of the idea of how a simulating halt decider would analyze the Peter Linz \hat{H} applied to its own Turing machine description we start by examining the behavior of an ordinary UTM.

When we hypothesize that the halt decider embedded in \hat{H} is simply a UTM then it seems that when the Peter Linz \hat{H} is applied to its own Turing machine description $\langle \hat{H} \rangle$ this specifies a computation that never halts.

$\hat{H}_0.q_0$ copies its input $\langle \hat{H}_1 \rangle$ to $\langle \hat{H}_2 \rangle$ then $\hat{H}_0.qx$ simulates \hat{H}_1 with the $\langle \hat{H}_2 \rangle$ copy then $\hat{H}_1.q_0$ copies its input $\langle \hat{H}_2 \rangle$ to $\langle \hat{H}_3 \rangle$ then $\hat{H}_1.qx$ simulates \hat{H}_2 with the $\langle \hat{H}_3 \rangle$ copy then $\hat{H}_2.q_0$ copies its input $\langle \hat{H}_3 \rangle$ to $\langle \hat{H}_4 \rangle$ then $\hat{H}_2.qx$ simulates \hat{H}_3 with the $\langle \hat{H}_4 \rangle$ copy then ...

This is expressed in figure 12.4 as a cycle from qx to q_0 to qx .

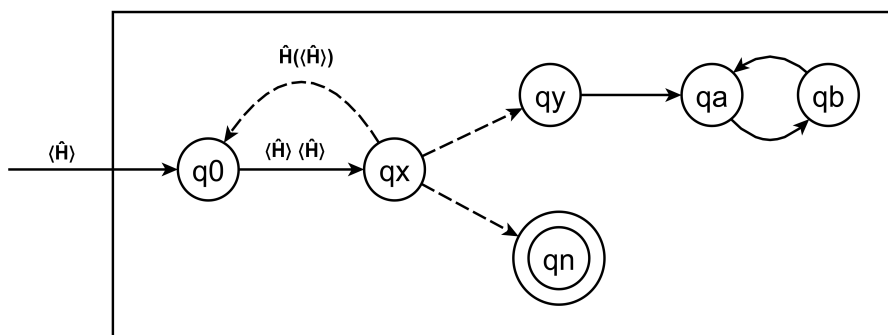

Figure 12.4 Turing Machine \hat{H} applied to $\langle \hat{H} \rangle$ input

Next we examine the behavior of \hat{H} applied to its own Turing machine description: $\langle \hat{H} \rangle$ when the halt decider at $\hat{H}.qx$ bases its halt status decision on simulating its input.

$\hat{H}(\langle \hat{H} \rangle)$ specifies an infinite cycle from $\hat{H}.qx$ to $\hat{H}.q0$ all the time that $\hat{H}.qx$ remains a pure simulator of its input. Every simulation that would never stop unless its simulating halt decider stops it at some point specifies infinite execution.

$\hat{H}(\langle \hat{H} \rangle)$ only stops because its simulating halt decider stops it at some point.

Within the hypothesis that the internal halt decider embedded within \hat{H} simulates its input \hat{H} applied to its own Turing machine description $\langle \hat{H} \rangle$ derives infinitely nested simulation, unless this simulation is aborted.

Self-Evident-Truth (premise[1])

When the pure simulation of a machine on its input never halts we know that the execution of this machine on its input never halts. **Derived from $UTM(P,I) \equiv P(I)$.**

Self-Evident-Truth (premise[2])

The $\langle \hat{H} \rangle$ $\langle \hat{H} \rangle$ input to the embedded simulating halt decider at $\hat{H}.qx$ cannot possibly reach its final state and halt whether or not the simulation is ever aborted.

∴ Sound Deductive Conclusion

The embedded simulating halt decider at $\hat{H}.qx$ correctly decides its input: $\langle \hat{H} \rangle$ $\langle \hat{H} \rangle$ is a computation that never halts.

$\hat{H}.q0$ $\langle \hat{H} \rangle$ specifies an infinite chain of invocations that is terminated at its third invocation. The first invocation of $\hat{H}.qx$ $\langle \hat{H} \rangle$, $\langle \hat{H} \rangle$ is the first element of an infinite chain of invocations.

It is common knowledge that when any invocation of an infinite chain of invocations is terminated that the whole chain terminates. That the first element of this infinite chain terminates after its third element has been terminated does not entail that this first element is an actual terminating computation.

For the first element to be an actual terminating computation it must terminate without any of the elements of the infinite chain of invocations being terminated.

Copyright 2016-2021 PL Olcott

Strachey, C 1965. An impossible program The Computer Journal, Volume 7, Issue 4, January 1965, Page 313, <https://doi.org/10.1093/comjnl/7.4.313>

Linz, Peter 1990. An Introduction to Formal Languages and Automata. Lexington/Toronto: D. C. Heath and Company. (318-320)

Sipser, Michael 1997. Introduction to the Theory of Computation. Boston: PWS Publishing Company (165-167)

Theorem 12.1

There does not exist any Turing machine H that behaves as required by Definition 12.1. The halting problem is therefore undecidable.

Proof: We assume the contrary, namely that there exists an algorithm, and consequently some Turing machine H , that solves the halting problem. The input to H will be the description (encoded in some form) of M , say w_M , as well as the input w . The requirement is then that, given any (w_M, w) , the Turing machine H will halt with either a yes or no answer. We achieve this by asking that H halt in one of two corresponding final states, say, q_y or q_n . The situation can be visualized by a block diagram like Figure 12.1. The intent of this diagram is to indicate that, if M is started in state q_0 with input (w_M, w) , it will eventually halt in state q_y or q_n . As required by Definition 12.1, we want H to operate according to the following rules:

$$q_0 w_M w \vdash^* H x_1 q_y x_2,$$

if M applied to w halts, and

$$q_0 w_M w \vdash^* H y_1 q_n y_2,$$

if M applied to w does not halt.

Figure 12.1

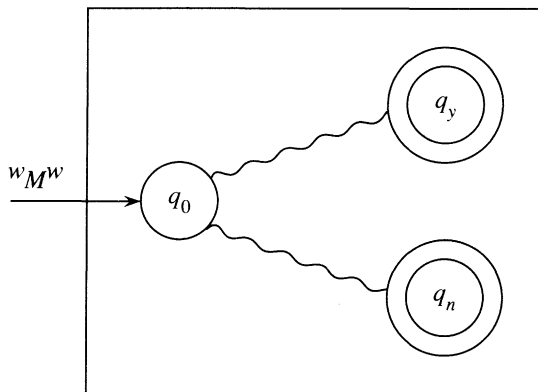
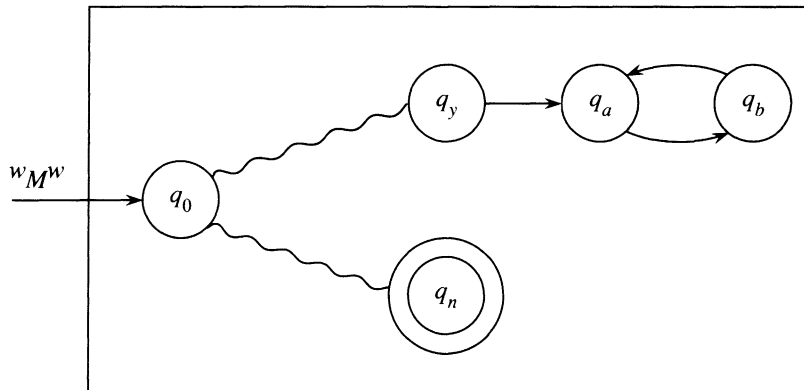

Figure 12.2



Next, we modify H to produce a Turing machine H' with the structure shown in Figure 12.2. With the added states in Figure 12.2 we want to convey that the transitions between state q_y and the new states q_a and q_b are to be made, regardless of the tape symbol, in such a way that the tape remains unchanged. The way this is done is straightforward. Comparing H and H' we see that, in situations where H reaches q_y and halts, the modified machine H' will enter an infinite loop. Formally, the action of H' is described by

$$q_0 w_M w \vdash_{H'}^* \infty,$$

if M applied to w halts, and

$$q_0 w_M w \vdash_{H'}^* y_1 q_n y_2,$$

if M applied to w does not halt.

From H' we construct another Turing machine \hat{H} . This new machine takes as input w_M , copies it, and then behaves exactly like H' . Then the action of \hat{H} is such that

$$q_0 w_M \vdash_{\hat{H}}^* q_0 w_M w_M \vdash_{\hat{H}}^* \infty,$$

if M applied to w_M halts, and

$$q_0 w_M \vdash_{\hat{H}}^* q_0 w_M w_M \vdash_{\hat{H}}^* y_1 q_n y_2,$$

if M applied to w_M does not halt.

Now \hat{H} is a Turing machine, so that it will have some description in Σ^* , say \hat{w} . This string, in addition to being the description of \hat{H} can also be used as input string. We can therefore legitimately ask what would happen if \hat{H} is applied to \hat{w} . From the above, identifying M with \hat{H} , we get

$$q_0\hat{w} \vdash^* \hat{H}\infty,$$

if \hat{H} applied to \hat{w} halts, and

$$q_0\hat{w} \vdash^* \hat{H}y_1q_ny_2,$$

if \hat{H} applied to \hat{w} does not halt. This is clearly nonsense. The contradiction tells us that our assumption of the existence of H , and hence the assumption of the decidability of the halting problem, must be false. ■