

## Halting problem undecidability and infinitely nested simulation

The pathological self-reference of the conventional halting problem proof counter-examples is overcome. The halt status of these examples is correctly determined. A simulating halt decider remains in pure simulation mode until after it determines that its input will never stop running unless its simulation is aborted. This eliminates the conventional feedback loop where the behavior of the halt decider effects the behavior of its input.

The x86utm operating system was created so that the halting problem could be examined concretely in the high level language of C. H is a function written in C that analyzes the x86 machine language execution trace of other functions written in C. H recognizes simple cases of infinite recursion and infinite loops. The conventional halting problem proof counter-example template is shown to simply be an input that does not halt.

H simulates its input with an x86 emulator until it determines that its input would never halt. As soon as H recognizes that its input would never halt it stops simulating this input and returns 0. For inputs that do halt H acts exactly as if it was an x86 emulator and simply runs its input to completion and then returns 1.

In theoretical computer science the random-access stored-program (RASP) machine model is an abstract machine used for the purposes of algorithm development and algorithm complexity theory. ...The RASP is closest of all the abstract models to the common notion of computer.

[https://en.wikipedia.org/wiki/Random-access\\_stored-program\\_machine](https://en.wikipedia.org/wiki/Random-access_stored-program_machine)

The C/x86 model of computation is known to be Turing equivalent on the basis that it maps to the RASP model for all computations having all of the memory that they need. As long as an C/x86 function is a pure function of its inputs the C/x86 model of computation can be relied upon as a much higher level of abstraction of the behavior of actual Turing machines.

### **Simulating Halt Decider Theorem (Olcott 2020):**

A simulating halt decider correctly decides that any input that never halts unless the simulating halt decider aborts its simulation of this input is an input that never halts. The above is verified as completely true entirely on the basis of the meaning of its words.

the Turing machine halting problem. Simply stated, the problem is: given the description of a Turing machine M and an input w, does M, when started in the initial configuration  $q_0w$ , perform a computation that eventually halts? (Linz:1990:317).

In computability theory, the halting problem is the problem of determining, from a description of an arbitrary computer program and an input, whether the program will finish running, or continue to run forever.

[https://en.wikipedia.org/wiki/Halting\\_problem](https://en.wikipedia.org/wiki/Halting_problem)

In order to show that the above two definitions have been satisfied we only have to show that (an at least partial) halt decider H does correctly decide whether or not its input description of a Turing machine or computer program would halt on its input.

Because H only acts as a pure simulator of its input until after its halt status decision has been made it has no behavior that can possibly effect the behavior of its input. Because of this H screens out its own address range in every execution trace that it examines. This is why we never see any instructions of H in any execution trace after an input calls H.

**Pathological Input** to a halt decider is stipulated to mean any input that was defined to do the opposite of whatever its corresponding halt decider decides as Sipser describes:

Now we construct a new Turing machine D with H as a subroutine. This new TM calls H to determine what M does when the input to M is its own description  $\langle M \rangle$ . Once D has determined this information, it does the opposite. (Sipser:1997:165)

When D is invoked with input  $\langle D \rangle$  we have pathological self-reference when D calls H with  $\langle D \rangle$  and does the opposite of whatever H returns.

### Does D halt on its own machine description $\langle D \rangle$ ?

This question can only be correctly answered after the pathology has been removed. When a halt decider only acts as a pure simulator of its input until after its halt status decision is made there is no feedback loop of back channel communication between the halt decider and its input that can prevent a correct halt status decision. In this case the halt decider is only examining the behavior of the input. It ignores its own behavior.

The standard pseudo-code halting problem template "proved" that the halting problem could never be solved on the basis that neither value of true (halting) nor false (not halting) could be correctly returned from the halt decider to the confounding input.

```
procedure compute_g(i): // (wikipedia:Halting Problem)
  if f(i, i) == 0 then // adapted from (Strachey, C 1965)
    return 0 // originally written in CPL
  else // ancestor of the BCPL, B and C
    loop forever // programming languages
```

This problem is overcome on the basis that a simulating halt decider would abort the simulation of its input before ever returning any value to this input. It aborts the simulation of its input on the basis that its input specifies what is essentially infinite recursion (infinitely nested simulation) to any simulating halt decider.

Every input to a simulating halt decider that only stops running when its simulation is aborted unequivocally specifies a computation that never halts. When input to a simulating halt decider cannot possibly reach its final state then we know that this input never halts.

### A simulating halt decider H divides all of its input into:

- (1) Those inputs that never halt while H remains a pure simulator (never halting).  
H aborts its simulation of these inputs and returns 0 for never halting.
- (2) Those inputs that halt while H remains a pure simulator (halting).  
H waits for its simulation of this input to complete and then returns 1 halting.

## Simulating partial halt decider H correctly decides that P(P) never halts (V1)

H analyzes the (currently updated) stored execution trace of its x86 emulation of P(P) after it simulates each instruction of input (P, P). As soon as a non-halting behavior pattern is matched H aborts the simulation of its input and decides that its input never halts.

The execution trace of the x86 emulation of P(P) by simulating halt decider H conclusively proves that P never halts unless H aborts its simulation of P. This provides complete proof that that the input to H never halts thus  $H(P,P)=0$  is correct.

```
// Simplified Linz A (Linz:1990:319)
// Strachey(1965) CPL translated to C
```

```
void P(u32 x)
{
    if (H(x, x))
        HERE: goto HERE;
}

int main()
{
    output("Input_Halts = ", H((u32)P, (u32)P));
}
```

```
_P()
[0000c36] (01) 55          push ebp
[0000c37] (02) 8bec        mov ebp,esp
[0000c39] (03) 8b4508     mov eax,[ebp+08] // 2nd Param
[0000c3c] (01) 50          push eax
[0000c3d] (03) 8b4d08     mov ecx,[ebp+08] // 1st Param
[0000c40] (01) 51          push ecx
[0000c41] (05) e820fdffff call 00000966 // call H
[0000c46] (03) 83c408     add esp,+08
[0000c49] (02) 85c0       test eax,eax
[0000c4b] (02) 7402       jz 0000c4f
[0000c4d] (02) ebfe       jmp 0000c4d
[0000c4f] (01) 5d          pop ebp
[0000c50] (01) c3          ret
Size in bytes:(0027) [0000c50]
```

```
_main()
[0000c56] (01) 55          push ebp
[0000c57] (02) 8bec        mov ebp,esp
[0000c59] (05) 68360c0000 push 0000c36 // push P
[0000c5e] (05) 68360c0000 push 0000c36 // push P
[0000c63] (05) e8fefcffff call 00000966 // call H(P,P)
[0000c68] (03) 83c408     add esp,+08
[0000c6b] (01) 50          push eax
[0000c6c] (05) 6857030000 push 00000357
[0000c71] (05) e810f7ffff call 00000386
[0000c76] (03) 83c408     add esp,+08
[0000c79] (02) 33c0       xor eax,eax
[0000c7b] (01) 5d          pop ebp
[0000c7c] (01) c3          ret
Size in bytes:(0039) [0000c7c]
```

machine address	stack address	stack data	machine code	assembly language
[00000c56]	[0010172a]	[00000000]	55	push ebp
[00000c57]	[0010172a]	[00000000]	8bec	mov ebp,esp
[00000c59]	[00101726]	[00000c36]	68360c0000	push 00000c36 // push P
[00000c5e]	[00101722]	[00000c36]	68360c0000	push 00000c36 // push P
[00000c63]	[0010171e]	[00000c68]	e8fefcffff	call 00000966 // call H(P,P)

Begin Local Halt Decider Simulation at Machine Address:c36

[00000c36]	[002117ca]	[002117ce]	55	push ebp
[00000c37]	[002117ca]	[002117ce]	8bec	mov ebp,esp
[00000c39]	[002117ca]	[002117ce]	8b4508	mov eax,[ebp+08]
[00000c3c]	[002117c6]	[00000c36]	50	push eax // push P
[00000c3d]	[002117c6]	[00000c36]	8b4d08	mov ecx,[ebp+08]
[00000c40]	[002117c2]	[00000c36]	51	push ecx // push P
[00000c41]	[002117be]	[00000c46]	e820fdffff	call 00000966 // call H(P,P)

[00000c36]	[0025c1f2]	[0025c1f6]	55	push ebp
[00000c37]	[0025c1f2]	[0025c1f6]	8bec	mov ebp,esp
[00000c39]	[0025c1f2]	[0025c1f6]	8b4508	mov eax,[ebp+08]
[00000c3c]	[0025c1ee]	[00000c36]	50	push eax // push P
[00000c3d]	[0025c1ee]	[00000c36]	8b4d08	mov ecx,[ebp+08]
[00000c40]	[0025c1ea]	[00000c36]	51	push ecx // push P
[00000c41]	[0025c1e6]	[00000c46]	e820fdffff	call 00000966 // call H(P,P)

Local Halt Decider: Infinite Recursion Detected Simulation Stopped

We do not see any of the x86 instructions of H in the above execution trace because we know that H is only acting as a pure simulator of its inputs until after it has made its halt status decision. This means that H cannot possibly have any effect on the behavior of its input during the above (execution trace / halt status analysis), thus H can safely ignore its own instructions in this halt status analysis.

**The infinite recursion detection criteria are met by the above execution trace:**

- P calls H twice in sequence from the same machine address.
- With the same parameters: (P,P) to H.
- With no conditional branch or indexed jump instructions in the execution trace of P.
- We know that there are no return instructions in H because we know that H is in pure simulation mode.

This conclusively proves that P never halts unless H aborts its simulation of P which proves that the behavior of the simulation of P on input P by H meets the following criteria:

**Simulating Halt Decider Theorem (Olcott 2020):**

A simulating halt decider correctly decides that any input that never halts unless the simulating halt decider aborts its simulation of this input is an input that never halts.

[00000c68]	[0010172a]	[00000000]	83c408	add esp,+08
[00000c6b]	[00101726]	[00000000]	50	push eax
[00000c6c]	[00101722]	[00000357]	6857030000	push 00000357
[00000c71]	[00101722]	[00000357]	e810f7ffff	call 00000386
Input_Halts = 0				
[00000c76]	[0010172a]	[00000000]	83c408	add esp,+08
[00000c79]	[0010172a]	[00000000]	33c0	xor eax,eax
[00000c7b]	[0010172e]	[00100000]	5d	pop ebp
[00000c7c]	[00101732]	[00000068]	c3	ret
Number_of_User_Instructions(27)				
Number of Instructions Executed(23721)				

## Simulating partial halt decider H1 correctly decides that P(P) halts (V2)

When we create an exact copy H1 of H and invoke H1(P,P) in main() it can see that H aborts its simulation of its input thus H1 returns 1 indicating that its input halts.

When H is the only halt decider it correctly reports that its input never halts unless it aborts its simulation of this input. When H1 is not the same halt decider as the one that P calls then H1 correctly reports that P halts because it can see that H aborts its simulation of P. In both cases H is correct.

```
void P(u32 x)
{
    if (H(x, x))
        HERE: goto HERE;
}

int main()
{
    output("Input_Halts = ", H1((u32)P, (u32)P));
}
```

x86 assembly language source-code for the above C functions.

```
_P()
[00000e52] (01) 55          push ebp
[00000e53] (02) 8bec        mov ebp,esp
[00000e55] (03) 8b4508     mov eax,[ebp+08]
[00000e58] (01) 50          push eax
[00000e59] (03) 8b4d08     mov ecx,[ebp+08]
[00000e5c] (01) 51          push ecx
[00000e5d] (05) e870feffff call 0000cd2 // call H
[00000e62] (03) 83c408     add esp,+08
[00000e65] (02) 85c0       test eax,eax
[00000e67] (02) 7402       jz 0000e6b // jmp if eax == 0
[00000e69] (02) ebfe       jmp 0000e69 // eax != 0
[00000e6b] (01) 5d          pop ebp
[00000e6c] (01) c3          ret
Size in bytes:(0027) [00000e6c]
```

```
_main()
[00000e72] (01) 55          push ebp
[00000e73] (02) 8bec        mov ebp,esp
[00000e75] (05) 68520e0000 push 00000e52 // push P
[00000e7a] (05) 68520e0000 push 00000e52 // push P
[00000e7f] (05) e88efcffff call 0000b12 // call H1
[00000e84] (03) 83c408     add esp,+08
[00000e87] (01) 50          push eax
[00000e88] (05) 6823030000 push 00000323
[00000e8d] (05) e8c0f4ffff call 0000352 // call output
[00000e92] (03) 83c408     add esp,+08
[00000e95] (02) 33c0       xor eax,eax
[00000e97] (01) 5d          pop ebp
[00000e98] (01) c3          ret // exit main()
Size in bytes:(0039) [00000e98]
```

## x86 Assembly Language Execution Trace of the above functions.

Because H and H1 only act as pure simulators of their input until after their halt status decision has been made they have no behavior that can possibly effect the behavior of their input. Because of this H and H1 screen out their own address range in every execution trace that they examine. This is why we never see any instructions of H or H1 in this execution trace.

Also the x86utm operating system only shows the execution user-code. It does not show the execution of any operating system code. This is controlled by a compile time switch.

	machine address	stack address	stack data	machine code	assembly language	
01.	[0000e72]	[00101a94]	[00000000]	55	push ebp	
02.	[0000e73]	[00101a94]	[00000000]	8bec	mov ebp,esp	
03.	[0000e75]	[00101a90]	[0000e52]	68520e0000	push 0000e52	// push P
04.	[0000e7a]	[00101a8c]	[0000e52]	68520e0000	push 0000e52	// push P
05.	[0000e7f]	[00101a88]	[0000e84]	e88efcffff	call 0000b12	// call H1
Begin Local Halt Decider Simulation at Machine Address:e52						
06.	[0000e52]	[00211b34]	[00211b38]	55	push ebp	
07.	[0000e53]	[00211b34]	[00211b38]	8bec	mov ebp,esp	
08.	[0000e55]	[00211b34]	[00211b38]	8b4508	mov eax,[ebp+08]	
09.	[0000e58]	[00211b30]	[0000e52]	50	push eax	// push P
10.	[0000e59]	[00211b30]	[0000e52]	8b4d08	mov ecx,[ebp+08]	
11.	[0000e5c]	[00211b2c]	[0000e52]	51	push ecx	// push P
12.	[0000e5d]	[00211b28]	[0000e62]	e870feffff	call 0000cd2	// call H
Begin Local Halt Decider Simulation at Machine Address:e52						
13.	[0000e52]	[0025c55c]	[0025c560]	55	push ebp	
14.	[0000e53]	[0025c55c]	[0025c560]	8bec	mov ebp,esp	
15.	[0000e55]	[0025c55c]	[0025c560]	8b4508	mov eax,[ebp+08]	
16.	[0000e58]	[0025c558]	[0000e52]	50	push eax	// push P
17.	[0000e59]	[0025c558]	[0000e52]	8b4d08	mov ecx,[ebp+08]	
18.	[0000e5c]	[0025c554]	[0000e52]	51	push ecx	// push P
19.	[0000e5d]	[0025c550]	[0000e62]	e870feffff	call 0000cd2	// call H
20.	[0000e52]	[002a6f84]	[002a6f88]	55	push ebp	
21.	[0000e53]	[002a6f84]	[002a6f88]	8bec	mov ebp,esp	
22.	[0000e55]	[002a6f84]	[002a6f88]	8b4508	mov eax,[ebp+08]	
23.	[0000e58]	[002a6f80]	[0000e52]	50	push eax	// push P
24.	[0000e59]	[002a6f80]	[0000e52]	8b4d08	mov ecx,[ebp+08]	
25.	[0000e5c]	[002a6f7c]	[0000e52]	51	push ecx	// push P
26.	[0000e5d]	[002a6f78]	[0000e62]	e870feffff	call 0000cd2	// call H
Local Halt Decider: Infinite Recursion Detected Simulation Stopped						
27.	[0000e62]	[00211b34]	[00211b38]	83c408	add esp,+08	
28.	[0000e65]	[00211b34]	[00211b38]	85c0	test eax,eax	
29.	[0000e67]	[00211b34]	[00211b38]	7402	jz 0000e6b	
30.	[0000e6b]	[00211b38]	[0000bcf]	5d	pop ebp	
31.	[0000e6c]	[00211b3c]	[0000e52]	c3	ret	// return from P
32.	[0000e84]	[00101a94]	[00000000]	83c408	add esp,+08	
33.	[0000e87]	[00101a90]	[00000001]	50	push eax	
34.	[0000e88]	[00101a8c]	[00000323]	6823030000	push 00000323	
35.	[0000e8d]	[00101a8c]	[00000323]	e8c0f4ffff	call 00000352	// call output
Input_Halts = 1						
36.	[0000e92]	[00101a94]	[00000000]	83c408	add esp,+08	
37.	[0000e95]	[00101a94]	[00000000]	33c0	xor eax,eax	
38.	[0000e97]	[00101a98]	[00100000]	5d	pop ebp	
39.	[0000e98]	[00101a9c]	[00000004]	c3	ret	// exit main()
Number_of_User_Instructions(39)						
Number of Instructions Executed(626930) would be 9,357 pages of output.						

Simulating halt deciders can only see the execution trace of instructions that they simulate. They cannot see the execution trace generated from another different simulating halt decider. H1 only has lines 06-12 and lines 27-31 in its stored execution trace it never sees lines 13-26 that belong to the stored execution trace of H. Because H1 has returned to main() it does not see any lines after line 31.

Simulating halt deciders always ignore the internal behavior of all operating system functions, the halt status of these functions is already known. Because simulating halt deciders are themselves operating system functions they always ignore their own behavior and the behavior of every other halt decider.

Because of the above reasons we can see that H does see that the infinite recursion criteria is met by its input and H1 never see that this criteria is met.

**Infinite recursion detection criteria:**

If the execution trace of function X() called by function Y() shows:

- (1) Function X() is called twice in sequence from the same machine address of Y().
- (2) With the same parameters to X().
- (3) With no conditional branch or indexed jump instructions in Y().
- (4) With no function call returns from X().

then the function call from Y() to X() is infinitely recursive.

Because H(P,P) and H1(P,P) are distinctly different computations they can have different behavior without contradiction.

The direct execution of P(P) shown in the next section is computationally equivalent to the pure simulation of P(P) invoked from main() by H1 shown above. Because P already has its own halt decider H1 never needs to abort its simulation of P(P) thus H1 stays in simulation mode.

When H is the only halt decider (as in the prior section) then it correctly determines that it must abort its simulation of P(P). H cannot simply wait for itself to abort its simulation of P(P) later on because it would never be aborted if H simply waited for itself to do this. This is computationally different than the direct invocation of P(P) in the next section.

H1(P,P) simulates P(P) as a slave process which executes H(P,P) as a part of this same slave process. H(P,P) simulates P(P) as its own slave process that H1 cannot see because each halt decider is a pure function of its own inputs. Because H1 and H are at different machine addresses they are not the same function executed with the same data.

The fact that H1 is called first causes H1 to monitor the results of the behavior of H(P,P). This creates a dependency of H1 on behavior of H(P,P). H(P,P) has no such dependency on another halt decider.

The fact that H and H1 are at different machine addresses and that H1 is called first makes two functions with identical machine code behave differently on the exact same input.

The fact that H and H1 are at different machine address derives a key difference in their execution trace that derives a key difference in their halt status decision.

The halt deciders look for the same function to be called with the same data twice in sequence. H1 is never called twice. H sees a function (itself) called twice in sequence with the same data.

Because H1 is called first and H1 is at a different machine address than H the abort simulation criteria is not met for H1. When the abort simulation criteria is met by H(P,P) then H1 sees that its input halts.

The fact that H and H1 are at different machines addresses and that H1 is called first makes two functions with identical machine code behave differently on the exact same input.



## The direct execution of P(P) halts (V3)

The execution trace of the x86 emulation of P(P) by simulating halt decider H conclusively proves that P cannot possibly ever reach its final state of 0xc3f. This provides complete proof that that the input to H never halts thus  $H(P,P)=0$  is correct.

```
// Simplified Linz H (Linz:1990:319)
// Strachey(1965) CPL translated to C
```

```
void P(u32 x)
{
    if (H(x, x))
        HERE: goto HERE;
}
```

```
int main()
{
    P((u32)P);
}
```

```
_P()
[0000c25] (01) 55          push ebp
[0000c26] (02) 8bec         mov ebp,esp
[0000c28] (03) 8b4508      mov eax,[ebp+08]
[0000c2b] (01) 50          push eax // 2nd Param
[0000c2c] (03) 8b4d08      mov ecx,[ebp+08]
[0000c2f] (01) 51          push ecx // 1st Param
[0000c30] (05) e820fdffff  call 00000955 // call H
[0000c35] (03) 83c408      add esp,+08
[0000c38] (02) 85c0         test eax,eax
[0000c3a] (02) 7402         jz 0000c3e
[0000c3c] (02) ebfe         jmp 0000c3c
[0000c3e] (01) 5d          pop ebp
[0000c3f] (01) c3          ret
Size in bytes:(0027) [0000c3f]
```

```
_main()
[0000c45] (01) 55          push ebp
[0000c46] (02) 8bec         mov ebp,esp
[0000c48] (05) 6825c000  push 0000c25 // push P
[0000c4d] (05) e8d3ffffff  call 0000c25 // call P(P)
[0000c52] (03) 83c404      add esp,+04
[0000c55] (02) 33c0         xor eax,eax
[0000c57] (01) 5d          pop ebp
[0000c58] (01) c3          ret
Size in bytes:(0020) [0000c58]
```

machine address	stack address	stack data	machine code	assembly language
[0000c45]	[001016d6]	[00000000]	55	push ebp
[0000c46]	[001016d6]	[00000000]	8bec	mov ebp,esp
[0000c48]	[001016d2]	[0000c25]	6825c000	push 0000c25 // push P
[0000c4d]	[001016ce]	[0000c52]	e8d3ffffff	call 0000c25 // call P <sub>0</sub> (P)
[0000c25]	[001016ca]	[001016d6]	55	push ebp // P <sub>0</sub> begins
[0000c26]	[001016ca]	[001016d6]	8bec	mov ebp,esp
[0000c28]	[001016ca]	[001016d6]	8b4508	mov eax,[ebp+08]
[0000c2b]	[001016c6]	[0000c25]	50	push eax // push P
[0000c2c]	[001016c6]	[0000c25]	8b4d08	mov ecx,[ebp+08]
[0000c2f]	[001016c2]	[0000c25]	51	push ecx // push P
[0000c30]	[001016be]	[0000c35]	e820fdffff	call 00000955 // call H <sub>0</sub> (P <sub>1</sub> ,P <sub>1</sub> )

```

Begin Local Halt Decider Simulation at Machine Address:c25
[0000c25][00211776][0021177a] 55      push ebp      // P1 begins
[0000c26][00211776][0021177a] 8bec      mov ebp,esp
[0000c28][00211776][0021177a] 8b4508    mov eax,[ebp+08]
[0000c2b][00211772][0000c25] 50      push eax      // push P
[0000c2c][00211772][0000c25] 8b4d08    mov ecx,[ebp+08]
[0000c2f][0021176e][0000c25] 51      push ecx      // push P
[0000c30][0021176a][0000c35] e820fdffff call 00000955 // call H1(P2,P2)

[0000c25][0025c19e][0025c1a2] 55      push ebp      // P2 begins
[0000c26][0025c19e][0025c1a2] 8bec      mov ebp,esp
[0000c28][0025c19e][0025c1a2] 8b4508    mov eax,[ebp+08]
[0000c2b][0025c19a][0000c25] 50      push eax      // push P
[0000c2c][0025c19a][0000c25] 8b4d08    mov ecx,[ebp+08]
[0000c2f][0025c196][0000c25] 51      push ecx      // push P
[0000c30][0025c192][0000c35] e820fdffff call 00000955 // call H2(P3,P3)
Local Halt Decider: Infinite Recursion Detected Simulation Stopped

```

**In the above computation (zero based addressing)  $H_0$  aborts the  $P_1$  invocation chain. No  $P(P)$  ever stops running unless  $H_0$  aborts its simulation of  $P_1$**

Subscripts indicate that a new process context (with its own RAM, stack and registers) has been created to simulate the virtual machine input to H. Every time H is called it creates a new process context to simulate its inputs.

$P_0$  and  $H_0$  are executed rather than simulated in a process context.  
 $P_1$  and  $H_1$  are simulated in the same process context and are slaves to  $H_0$   
 $P_2$  and  $H_2$  are simulated in the same process context and are slaves to  $H_1$

```

[0000c35][001016ca][001016d6] 83c408    add esp,+08
[0000c38][001016ca][001016d6] 85c0      test eax,eax
[0000c3a][001016ca][001016d6] 7402      jz 0000c3e
[0000c3e][001016ce][0000c52] 5d      pop ebp
[0000c3f][001016d2][0000c25] c3      ret
[0000c52][001016d6][00000000] 83c404    add esp,+04
[0000c55][001016d6][00000000] 33c0      xor eax,eax
[0000c57][001016da][00100000] 5d      pop ebp
[0000c58][001016de][00000084] c3      ret
Number_of_User_Instructions(34)
Number of Instructions Executed(23729)

```

- (1) H does perform a pure simulation of its input until after it makes its halt status decision.
- (2) It can be verified that this is a pure simulation on the basis that the execution trace does what the x86 source-code of P specifies.
- (3) Because there are no control flow instructions in the execution trace that can possibly escape the infinite recursion the execution trace proves that a pure simulation of the above input cannot possibly ever reach its final state.
- (4) Therefore H was correct when it decided that its input never halts.

**The direct execution of a machine is a distinctly different computation than the simulation of this same machine description by a simulating halt decider that can abort its simulation of this input. This allows the execution of  $P(P)$  to halt and the simulation of  $P(P)$  to be correctly decided as never halting without contradiction.**

## Simulating partial halt decider H correctly decides that Infinite\_Loop() never halts

```

void Infinite_Loop()
{
    HERE: goto HERE;
}

int main()
{
    u32 Input_would_Halt2 = H((u32)Infinite_Loop, (u32)Infinite_Loop);
    Output("Input_would_Halt2 = ", Input_would_Halt2);
}

```

```

_Infinite_Loop()
[00000ab0] (01) 55          push ebp
[00000ab1] (02) 8bec         mov ebp,esp
[00000ab3] (02) ebfe         jmp 00000ab3
[00000ab5] (01) 5d          pop ebp
[00000ab6] (01) c3          ret
Size in bytes:(0007) [00000ab6]

```

```

_main()
[00000c00] (01) 55          push ebp
[00000c01] (02) 8bec         mov ebp,esp
[00000c03] (01) 51          push ecx
[00000c04] (05) 68b00a0000  push 00000ab0
[00000c09] (05) 68b00a0000  push 00000ab0
[00000c0e] (05) e84dfdffff  call 00000960
[00000c13] (03) 83c408      add esp,+08
[00000c16] (03) 8945fc      mov [ebp-04],eax
[00000c19] (03) 8b45fc      mov eax,[ebp-04]
[00000c1c] (01) 50          push eax
[00000c1d] (05) 684b030000  push 0000034b
[00000c22] (05) e859f7ffff  call 00000380
[00000c27] (03) 83c408      add esp,+08
[00000c2a] (02) 33c0        xor eax,eax
[00000c2c] (02) 8be5        mov esp,ebp
[00000c2e] (01) 5d          pop ebp
[00000c2f] (01) c3          ret
Size in bytes:(0048) [00000c2f]

```

## Execution Trace of H(Infinite\_Loop, Infinite\_Loop)

machine address	stack address	stack data	machine code	assembly language
[00000c00]	[00101693]	[00000000]	55	push ebp
[00000c01]	[00101693]	[00000000]	8bec	mov ebp,esp
[00000c03]	[0010168f]	[00000000]	51	push ecx
[00000c04]	[0010168b]	[00000ab0]	68b00a0000	push 00000ab0
[00000c09]	[00101687]	[00000ab0]	68b00a0000	push 00000ab0
[00000c0e]	[00101683]	[00000c13]	e84dfdffff	call 00000960

Begin Local Halt Decider Simulation at Machine Address:ab0

[00000ab0]	[00211733]	[00211737]	55	push ebp
[00000ab1]	[00211733]	[00211737]	8bec	mov ebp,esp
[00000ab3]	[00211733]	[00211737]	ebfe	jmp 00000ab3
[00000ab3]	[00211733]	[00211737]	ebfe	jmp 00000ab3

Local Halt Decider: Infinite Loop Detected Simulation Stopped

```

[0000c13] [0010168f] [00000000] 83c408    add esp,+08
[0000c16] [0010168f] [00000000] 8945fc    mov [ebp-04],eax
[0000c19] [0010168f] [00000000] 8b45fc    mov eax,[ebp-04]
[0000c1c] [0010168b] [00000000] 50        push eax
[0000c1d] [00101687] [0000034b] 684b030000 push 0000034b
[0000c22] [00101687] [0000034b] e859f7ffff call 00000380
Input_would_Halt2 = 0
[0000c27] [0010168f] [00000000] 83c408    add esp,+08
[0000c2a] [0010168f] [00000000] 33c0      xor eax,eax
[0000c2c] [00101693] [00000000] 8be5      mov esp,ebp
[0000c2e] [00101697] [00100000] 5d        pop ebp
[0000c2f] [0010169b] [00000050] c3        ret
Number_of_User_Instructions(21)
Number_of_Instructions_Executed(640)

```

## Simulating partial halt decider H decides that Infinite\_Recursion() never halts

```

void Infinite_Recursion(u32 N)
{
    Infinite_Recursion(N);
}

int main()
{
    u32 Input_Halts = H((u32)Infinite_Recursion, 3);
    Output("Input_Halts = ", Input_Halts);
}

```

```

_Infinite_Recursion()
[00000ac6] (01) 55          push ebp
[00000ac7] (02) 8bec         mov ebp,esp
[00000ac9] (03) 8b4508      mov eax,[ebp+08]
[00000acc] (01) 50          push eax
[00000acd] (05) e8f4ffffff  call 00000ac6
[00000ad2] (03) 83c404      add esp,+04
[00000ad5] (01) 5d          pop ebp
[00000ad6] (01) c3          ret
Size in bytes:(0017) [00000ad6]

```

```

_main()
[00000c46] (01) 55          push ebp
[00000c47] (02) 8bec         mov ebp,esp
[00000c49] (01) 51          push ecx
[00000c4a] (02) 6a03         push +03
[00000c4c] (05) 68c60a0000  push 00000ac6
[00000c51] (05) e810fdffff  call 00000966
[00000c56] (03) 83c408      add esp,+08
[00000c59] (03) 8945fc      mov [ebp-04],eax
[00000c5c] (03) 8b45fc      mov eax,[ebp-04]
[00000c5f] (01) 50          push eax
[00000c60] (05) 6857030000  push 00000357
[00000c65] (05) e81cf7ffff  call 00000386
[00000c6a] (03) 83c408      add esp,+08
[00000c6d] (02) 33c0         xor eax,eax
[00000c6f] (02) 8be5         mov esp,ebp
[00000c71] (01) 5d          pop ebp
[00000c72] (01) c3          ret
Size in bytes:(0045) [00000c72]

```

## Execution Trace of H(Infinite\_Recursion, 3)

machine address	stack address	stack data	machine code	assembly language
[00000c46]	[001016fa]	[00000000]	55	push ebp
[00000c47]	[001016fa]	[00000000]	8bec	mov ebp,esp
[00000c49]	[001016f6]	[00000000]	51	push ecx
[00000c4a]	[001016f2]	[00000003]	6a03	push +03
[00000c4c]	[001016ee]	[00000ac6]	68c60a0000	push 00000ac6
[00000c51]	[001016ea]	[00000c56]	e810fdffff	call 00000966

```

Begin Local Halt Decider Simulation at Machine Address:ac6
[0000ac6][0021179a][0021179e] 55      push ebp
[0000ac7][0021179a][0021179e] 8bec   mov ebp,esp
[0000ac9][0021179a][0021179e] 8b4508 mov eax,[ebp+08]
[0000acc][00211796][00000003] 50     push eax
[0000acd][00211792][0000ad2] e8f4ffff call 0000ac6
[0000ac6][0021178e][0021179a] 55     push ebp
[0000ac7][0021178e][0021179a] 8bec   mov ebp,esp
[0000ac9][0021178e][0021179a] 8b4508 mov eax,[ebp+08]
[0000acc][0021178a][00000003] 50     push eax
[0000acd][00211786][0000ad2] e8f4ffff call 0000ac6
Local Halt Decider: Infinite Recursion Detected Simulation Stopped

```

\_Infinite\_Recursion() calls itself recursively with the same input. It has no escape from this infinite recursion. It recognizes this infinite behavior pattern, aborts its simulation of \_Infinite\_Recursion() and reports that this input never halts.

```

[0000c56][001016f6][00000000] 83c408 add esp,+08
[0000c59][001016f6][00000000] 8945fc mov [ebp-04],eax
[0000c5c][001016f6][00000000] 8b45fc mov eax,[ebp-04]
[0000c5f][001016f2][00000000] 50     push eax
[0000c60][001016ee][00000357] 6857030000 push 00000357
[0000c65][001016ee][00000357] e81cf7ffff call 00000386
Input_Halts = 0
[0000c6a][001016f6][00000000] 83c408 add esp,+08
[0000c6d][001016f6][00000000] 33c0   xor eax,eax
[0000c6f][001016fa][00000000] 8be5   mov esp,ebp
[0000c71][001016fe][00100000] 5d     pop ebp
[0000c72][00101702][00000068] c3     ret
Number_of_User_Instructions(27)
Number of Instructions Executed(1240)

```

#### Infinite recursion detection criteria:

If the execution trace of function X() called by function Y() shows:

- (1) Function X() is called twice in sequence from the same machine address of Y().
- (2) With the same parameters to X().
- (3) With no conditional branch or indexed jump instructions in Y().
- (4) With no function call returns from X().

then the function call from Y() to X() is infinitely recursive.

## Simulating partial halt decider H decides that Factorial(3) halts

```
int Factorial(int n)
{
    output("Factorial(n)",n);
    if (n > 1)
        return n * Factorial(n - 1);
    else
        return 1;
}

int main()
{
    output("Input_Halts = ", H(Factorial, 3));
}
```

```
_Factorial()
[0000de2] (01) 55          push ebp
[0000de3] (02) 8bec        mov ebp,esp
[0000de5] (03) 8b4508     mov eax,[ebp+08]
[0000de8] (01) 50          push eax
[0000de9] (05) 6813030000 push 00000313
[0000dee] (05) e85ff5ffff call 00000352
[0000df3] (03) 83c408     add esp,+08
[0000df6] (04) 837d0801   cmp dword [ebp+08],+01
[0000dfa] (02) 7e17       jng 0000e13
[0000dfc] (03) 8b4d08     mov ecx,[ebp+08]
[0000dff] (03) 83e901     sub ecx,+01
[0000e02] (01) 51          push ecx
[0000e03] (05) e8daffffff call 0000de2
[0000e08] (03) 83c404     add esp,+04
[0000e0b] (04) 0faf4508   imul eax,[ebp+08]
[0000e0f] (02) eb07       jmp 0000e18
[0000e11] (02) eb05       jmp 0000e18
[0000e13] (05) b801000000 mov eax,00000001
[0000e18] (01) 5d          pop ebp
[0000e19] (01) c3          ret
Size in bytes:(0056) [0000e19]
```

```
_main()
[0000ea2] (01) 55          push ebp
[0000ea3] (02) 8bec        mov ebp,esp
[0000ea5] (02) 6a03       push +03
[0000ea7] (05) 68e20d0000 push 0000de2
[0000eac] (05) e821feffff call 0000cd2
[0000eb1] (03) 83c408     add esp,+08
[0000eb4] (01) 50          push eax
[0000eb5] (05) 6823030000 push 00000323
[0000eba] (05) e893f4ffff call 00000352
[0000ebf] (03) 83c408     add esp,+08
[0000ec2] (02) 33c0       xor eax,eax
[0000ec4] (01) 5d          pop ebp
[0000ec5] (01) c3          ret
Size in bytes:(0036) [0000ec5]
```

	machine address	stack address	stack data	machine code	assembly language
...	[0000ea2]	[00101ae7]	[00000000]	55	push ebp
...	[0000ea3]	[00101ae7]	[00000000]	8bec	mov ebp,esp
...	[0000ea5]	[00101ae3]	[00000003]	6a03	push +03
...	[0000ea7]	[00101adf]	[00000de2]	68e20d0000	push 00000de2
...	[0000eac]	[00101adb]	[00000eb1]	e821feffff	call 00000cd2
Begin Local Halt Decider Simulation at Machine Address:de2					
...	[0000de2]	[00211b87]	[00211b8b]	55	push ebp
...	[0000de3]	[00211b87]	[00211b8b]	8bec	mov ebp,esp
...	[0000de5]	[00211b87]	[00211b8b]	8b4508	mov eax,[ebp+08]
...	[0000de8]	[00211b83]	[00000003]	50	push eax
...	[0000de9]	[00211b7f]	[00000313]	6813030000	push 00000313
---	[0000dee]	[00211b7f]	[00000313]	e85ff5ffff	call 00000352
Factorial(n)3					
...	[0000df3]	[00211b87]	[00211b8b]	83c408	add esp,+08
...	[0000df6]	[00211b87]	[00211b8b]	837d0801	cmp dword [ebp+08],+01
...	[0000dfa]	[00211b87]	[00211b8b]	7e17	jng 0000e13
...	[0000dfc]	[00211b87]	[00211b8b]	8b4d08	mov ecx,[ebp+08]
...	[0000dff]	[00211b87]	[00211b8b]	83e901	sub ecx,+01
...	[0000e02]	[00211b83]	[00000002]	51	push ecx
...	[0000e03]	[00211b7f]	[00000e08]	e8daffffff	call 00000de2
...	[0000de2]	[00211b7b]	[00211b87]	55	push ebp
...	[0000de3]	[00211b7b]	[00211b87]	8bec	mov ebp,esp
...	[0000de5]	[00211b7b]	[00211b87]	8b4508	mov eax,[ebp+08]
...	[0000de8]	[00211b77]	[00000002]	50	push eax
...	[0000de9]	[00211b73]	[00000313]	6813030000	push 00000313
---	[0000dee]	[00211b73]	[00000313]	e85ff5ffff	call 00000352
Factorial(n)2					
...	[0000df3]	[00211b7b]	[00211b87]	83c408	add esp,+08
...	[0000df6]	[00211b7b]	[00211b87]	837d0801	cmp dword [ebp+08],+01
...	[0000dfa]	[00211b7b]	[00211b87]	7e17	jng 0000e13
...	[0000dfc]	[00211b7b]	[00211b87]	8b4d08	mov ecx,[ebp+08]
...	[0000dff]	[00211b7b]	[00211b87]	83e901	sub ecx,+01
...	[0000e02]	[00211b77]	[00000001]	51	push ecx
...	[0000e03]	[00211b73]	[00000e08]	e8daffffff	call 00000de2
...	[0000de2]	[00211b6f]	[00211b7b]	55	push ebp
...	[0000de3]	[00211b6f]	[00211b7b]	8bec	mov ebp,esp
...	[0000de5]	[00211b6f]	[00211b7b]	8b4508	mov eax,[ebp+08]
...	[0000de8]	[00211b6b]	[00000001]	50	push eax
...	[0000de9]	[00211b67]	[00000313]	6813030000	push 00000313
---	[0000dee]	[00211b67]	[00000313]	e85ff5ffff	call 00000352
Factorial(n)1					
...	[0000df3]	[00211b6f]	[00211b7b]	83c408	add esp,+08
...	[0000df6]	[00211b6f]	[00211b7b]	837d0801	cmp dword [ebp+08],+01
...	[0000dfa]	[00211b6f]	[00211b7b]	7e17	jng 0000e13
...	[0000e13]	[00211b6f]	[00211b7b]	b801000000	mov eax,00000001
...	[0000e18]	[00211b73]	[00000e08]	5d	pop ebp
...	[0000e19]	[00211b77]	[00000001]	c3	ret
...	[0000eb1]	[00101ae7]	[00000000]	83c408	add esp,+08
...	[0000eb4]	[00101ae3]	[00000001]	50	push eax
...	[0000eb5]	[00101adf]	[00000323]	6823030000	push 00000323
---	[0000eba]	[00101adf]	[00000323]	e893f4ffff	call 00000352
Input_Halts = 1					
...	[0000ebf]	[00101ae7]	[00000000]	83c408	add esp,+08
...	[0000ec2]	[00101ae7]	[00000000]	33c0	xor eax,eax
...	[0000ec4]	[00101aeb]	[00100000]	5d	pop ebp
...	[0000ec5]	[00101aef]	[000000c8]	c3	ret
Number_of_User_Instructions(51)					
Number_of_Instructions_Executed(3714)					



# Strachey's Impossible Program

To the Editor,  
The Computer Journal.

## An impossible program

Sir,

A well-known piece of folk-lore among programmers holds that it is impossible to write a program which can examine any other program and tell, in every case, if it will terminate or get into a closed loop when it is run. I have never actually seen a proof of this in print, and though Alan Turing once gave me a verbal proof (in a railway carriage on the way to a Conference at the NPL in 1953), I unfortunately and promptly forgot the details. This left me with an uneasy feeling that the proof must be long or complicated, but in fact it is so short and simple that it may be of interest to casual readers. The version below uses CPL, but not in any essential way.

Suppose  $T[R]$  is a Boolean function taking a routine (or program)  $R$  with no formal or free variables as its argument and that for all  $R$ ,  $T[R]$  — True if  $R$  terminates if run and that  $T[R] = \text{False}$  if  $R$  does not terminate. Consider the routine  $P$  defined as follows

```
rec routine P
  §L:if T[P] go to L
  Return §
```

If  $T[P] = \text{True}$  the routine  $P$  will loop, and it will only terminate if  $T[P] = \text{False}$ . In each case  $T[P]$  has exactly the wrong value, and this contradiction shows that the function  $T$  cannot exist.

Yours faithfully,  
C. STRACHEY.

Churchill College,  
Cambridge.

**Strachey, C 1965.** An impossible program The Computer Journal, Volume 7, Issue 4, January 1965, Page 313, <https://doi.org/10.1093/comjnl/7.4.313>

## Peter Linz $\hat{H}$ applied to the Turing machine description of itself: $\langle \hat{H} \rangle$

The following simplifies the syntax for the definition of the Linz Turing machine  $\hat{H}$ , it is now a single machine with a single start state. A simulating halt decider is embedded at  $\hat{H}.qx$ .

$\hat{H}.q0 \langle \hat{H}_1 \rangle \vdash^* \hat{H}.qx \langle \hat{H}_1 \rangle \langle \hat{H}_2 \rangle \vdash^* \hat{H}.qy \infty$   
if the simulated  $\langle \hat{H}_1 \rangle$  applied to  $\langle \hat{H}_2 \rangle$  halts, and

$\hat{H}.q0 \langle \hat{H}_1 \rangle \vdash^* \hat{H}.qx \langle \hat{H}_1 \rangle \langle \hat{H}_2 \rangle \vdash^* \hat{H}.qn$   
if the simulated  $\langle \hat{H}_1 \rangle$  applied to  $\langle \hat{H}_2 \rangle$  does not halt

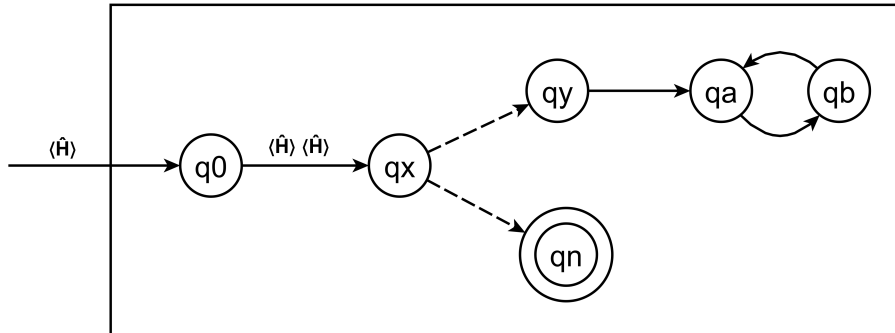

Figure 12.3 Turing Machine  $\hat{H}$  applied to  $\langle \hat{H} \rangle$

$\hat{H}$  applied to  $\langle \hat{H} \rangle$  is exactly analogous to `int main() { P((u32)P); }` (shown above).

$\hat{H}.qx$  applied to  $\langle \hat{H} \rangle \langle \hat{H} \rangle$  is exactly analogous to `H(P,P)` called from `main() { P((u32)P); }`

When  $\hat{H}$  or `P` are directly executed their behavior may not be the same as when they are simulated by a simulating halt decider that can abort their simulation. That a pair of computations are not equivalent allows them to have opposite behavior without contradiction.

When we define  $\hat{J}$  to be exactly like  $\hat{H}$  except that it has a UTM at  $\hat{J}.qx$  instead of a simulating halt decider then we can see that  $\hat{J}$  applied to  $\langle \hat{J} \rangle$  never halts.

$\hat{J}$  copies its input  $\langle \hat{J}_1 \rangle$  to  $\langle \hat{J}_2 \rangle$  then simulates this input  $\hat{J}_1$  with its input  $\langle \hat{J}_2 \rangle$   
which copies its input  $\langle \hat{J}_2 \rangle$  to  $\langle \hat{J}_3 \rangle$  then simulates this input  $\hat{J}_2$  with its input  $\langle \hat{J}_3 \rangle$   
which copies its input  $\langle \hat{J}_3 \rangle$  to  $\langle \hat{J}_4 \rangle$  then simulates this input  $\hat{J}_3$  with its input  $\langle \hat{J}_4 \rangle$  ...

Because it is obvious that  $\hat{J}$  on input  $\langle \hat{J} \rangle$  remains in infinitely nested simulation thus never halts it can be easily understood that  $\hat{H}$  on input  $\langle \hat{H} \rangle$  would have this same (never halting) behavior while the simulating halt decider at  $\hat{H}.qx$  continues to remain in pure simulation (UTM) mode.

The state transition following  $\hat{H}.qx$  to  $\hat{H}.q0$  is between different instances of  $\hat{H}$ .

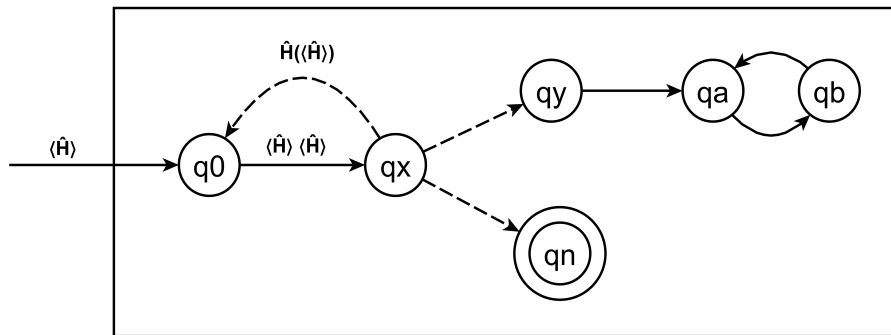

**Figure 12.4 Turing Machine  $\hat{H}$  applied to  $\langle \hat{H} \rangle$  input**

- (a) While the simulating halt decider at  $\hat{H}.qx$  remains in pure simulation (UTM) mode its input  $\langle \hat{H}_1 \rangle \langle \hat{H}_2 \rangle$  never halts.
- (b) Every computation that never halts while its simulating halt decider remains in pure simulation (UTM) mode is a computation that never halts.

**Simulating Halt Decider Theorem (Olcott 2020):**

A simulating halt decider correctly decides that any input that never halts unless the simulating halt decider aborts its simulation of this input is an input that never halts.

the Turing machine halting problem. Simply stated, the problem is: given the description of a Turing machine  $M$  and an input  $w$ , does  $M$ , when started in the initial configuration  $q_0w$ , perform a computation that eventually halts? (Linz:1990:317).

In order to show that the above definition has been satisfied we only have to show that halt decider  $\hat{H}.qx$  does correctly decide whether or not its input description  $\langle \hat{H}_1 \rangle$  of a Turing machine would halt on its input  $\langle \hat{H}_2 \rangle$ .

Just like the fact that `int main() { H(P,P); }` correctly decides that its input never halts even though `int main() { P(P); }` does halt the input to  $\hat{H}.qx$   $\langle \hat{H}_1 \rangle \langle \hat{H}_2 \rangle$  is correctly decided as never halting even though  $\hat{H}$  applied to  $\langle \hat{H}_1 \rangle$  halts.

The fact that  $\hat{H}$  applied to  $\langle \hat{H} \rangle$  transitions to its final state of  $\hat{H}.qn$  and halts does not nullify the fact that  $\hat{H}.qx$   $\langle \hat{H} \rangle \langle \hat{H} \rangle$  correctly decides that its input never halts. Distinctly different computations can have different behavior without contradiction.

The execution of  $\hat{H}.qx$  is the outer-most instance of what would otherwise be an infinite set of nested simulations. It is the only instance of  $\hat{H}.qx$  that is not under the dominion of another instance of  $\hat{H}.qx$ . This makes this outermost instance computationally distinct from the inner instances.

**Strachey, C 1965.** An impossible program The Computer Journal, Volume 7, Issue 4, January 1965, Page 313, <https://doi.org/10.1093/comjnl/7.4.313>

**Linz, Peter 1990.** An Introduction to Formal Languages and Automata. Lexington/Toronto: D. C. Heath and Company. (318-320)

**Sipser, Michael 1997.** Introduction to the Theory of Computation. Boston: PWS Publishing Company (165-167)

**Theorem 12.1**

There does not exist any Turing machine  $H$  that behaves as required by Definition 12.1. The halting problem is therefore undecidable.

**Proof:** We assume the contrary, namely that there exists an algorithm, and consequently some Turing machine  $H$ , that solves the halting problem. The input to  $H$  will be the description (encoded in some form) of  $M$ , say  $w_M$ , as well as the input  $w$ . The requirement is then that, given any  $(w_M, w)$ , the Turing machine  $H$  will halt with either a yes or no answer. We achieve this by asking that  $H$  halt in one of two corresponding final states, say,  $q_y$  or  $q_n$ . The situation can be visualized by a block diagram like Figure 12.1. The intent of this diagram is to indicate that, if  $M$  is started in state  $q_0$  with input  $(w_M, w)$ , it will eventually halt in state  $q_y$  or  $q_n$ . As required by Definition 12.1, we want  $H$  to operate according to the following rules:

$$q_0 w_M w \vdash^* H x_1 q_y x_2,$$

if  $M$  applied to  $w$  halts, and

$$q_0 w_M w \vdash^* H y_1 q_n y_2,$$

if  $M$  applied to  $w$  does not halt.

**Figure 12.1**

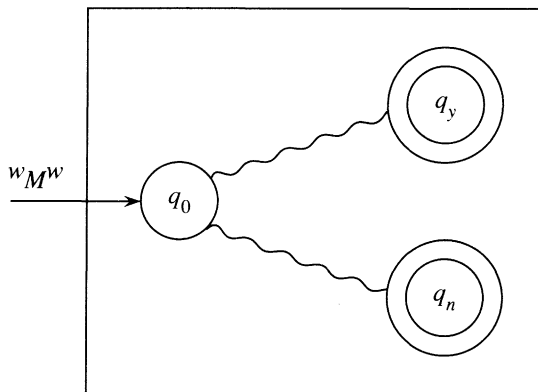
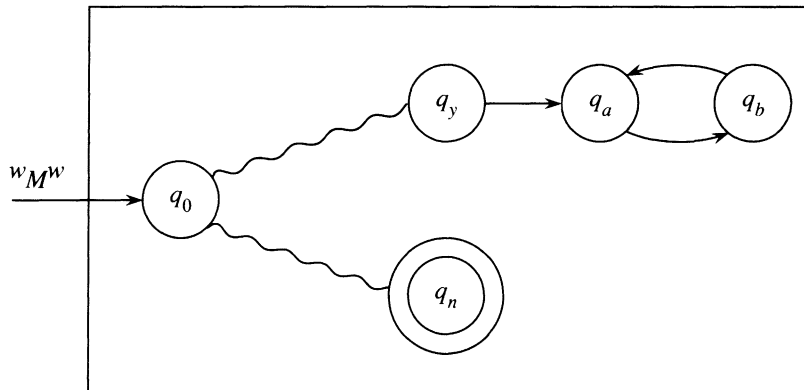

Figure 12.2



Next, we modify  $H$  to produce a Turing machine  $H'$  with the structure shown in Figure 12.2. With the added states in Figure 12.2 we want to convey that the transitions between state  $q_y$  and the new states  $q_a$  and  $q_b$  are to be made, regardless of the tape symbol, in such a way that the tape remains unchanged. The way this is done is straightforward. Comparing  $H$  and  $H'$  we see that, in situations where  $H$  reaches  $q_y$  and halts, the modified machine  $H'$  will enter an infinite loop. Formally, the action of  $H'$  is described by

$$q_0 w_M w \vdash_{H'}^* \infty,$$

if  $M$  applied to  $w$  halts, and

$$q_0 w_M w \vdash_{H'}^* y_1 q_n y_2,$$

if  $M$  applied to  $w$  does not halt.

From  $H'$  we construct another Turing machine  $\hat{H}$ . This new machine takes as input  $w_M$ , copies it, and then behaves exactly like  $H'$ . Then the action of  $\hat{H}$  is such that

$$q_0 w_M \vdash_{\hat{H}}^* q_0 w_M w_M \vdash_{\hat{H}}^* \infty,$$

if  $M$  applied to  $w_M$  halts, and

$$q_0 w_M \vdash_{\hat{H}}^* q_0 w_M w_M \vdash_{\hat{H}}^* y_1 q_n y_2,$$

if  $M$  applied to  $w_M$  does not halt.

Now  $\hat{H}$  is a Turing machine, so that it will have some description in  $\Sigma^*$ , say  $\hat{w}$ . This string, in addition to being the description of  $\hat{H}$  can also be used as input string. We can therefore legitimately ask what would happen if  $\hat{H}$  is applied to  $\hat{w}$ . From the above, identifying  $M$  with  $\hat{H}$ , we get

$$q_0\hat{w} \vdash^* \hat{H}\infty,$$

if  $\hat{H}$  applied to  $\hat{w}$  halts, and

$$q_0\hat{w} \vdash^* \hat{H}y_1q_ny_2,$$

if  $\hat{H}$  applied to  $\hat{w}$  does not halt. This is clearly nonsense. The contradiction tells us that our assumption of the existence of  $H$ , and hence the assumption of the decidability of the halting problem, must be false. ■