

## Peter Linz $\hat{H}$ applied to the Turing machine description of itself: $\hat{w}$

When we assume that the halt decider embedded in  $\hat{H}$  is simply a UTM does this define a computation that never halts when  $\hat{H}$  is applied to its own Turing machine description?

The following simplifies the syntax for the definition of the Linz Turing machine  $\hat{H}$ , it is now a single machine with a single start state. The halt decider is embedded at state  $\hat{H}.qx$ .

$\hat{H}.q_0 wM \vdash^* \hat{H}.qx wM wM \vdash^* \hat{H}.qy \infty$   
if  $M$  applied to  $wM$  halts, and

$\hat{H}.q_0 wM \vdash^* \hat{H}.qx wM wM \vdash^* \hat{H}.qn$   
if  $M$  applied to  $wM$  does not halt

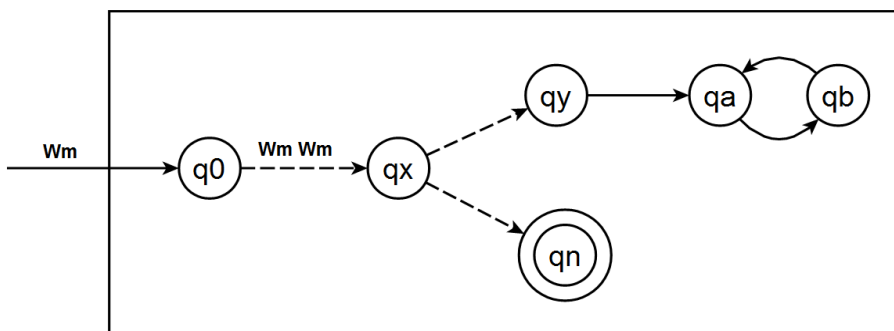

Figure 12.3 Turing Machine  $\hat{H}$

$\hat{H}.q_0$  copies its input then  $\hat{H}.qx$  simulates this input with the copy then  $\hat{H}.q_0$  copies its input then  $\hat{H}.qx$  simulates this input with the copy then  $\hat{H}.q_0$  copies its input then  $\hat{H}.qx$  simulates this input with the copy then...  
**This is expressed in figure 12.4 as a cycle from  $qx$  to  $q_0$  to  $qx$ .**

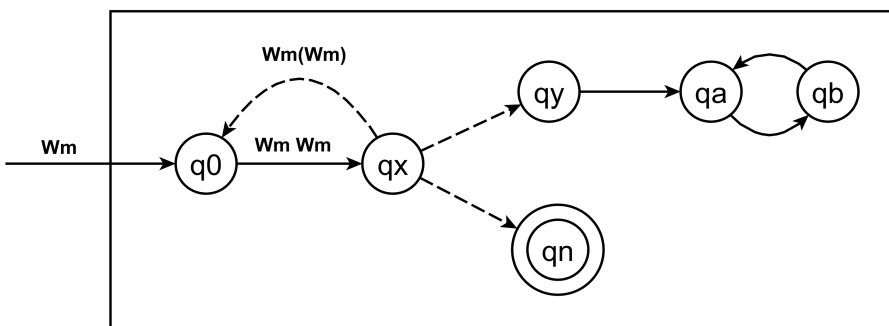

Figure 12.4 Turing Machine  $\hat{H}$

Within the hypothesis that the internal halt decider embedded within  $\hat{H}$  simulates its input  $\hat{H}$  applied to its own Turing machine description  $\hat{w}$  seems to derive infinitely nested simulation, unless this simulation is aborted.

**Linz, Peter 1990.** An Introduction to Formal Languages and Automata. Lexington/Toronto: D. C. Heath and Company. (318-320)

**Theorem 12.1**

There does not exist any Turing machine  $H$  that behaves as required by Definition 12.1. The halting problem is therefore undecidable.

**Proof:** We assume the contrary, namely that there exists an algorithm, and consequently some Turing machine  $H$ , that solves the halting problem. The input to  $H$  will be the description (encoded in some form) of  $M$ , say  $w_M$ , as well as the input  $w$ . The requirement is then that, given any  $(w_M, w)$ , the Turing machine  $H$  will halt with either a yes or no answer. We achieve this by asking that  $H$  halt in one of two corresponding final states, say,  $q_y$  or  $q_n$ . The situation can be visualized by a block diagram like Figure 12.1. The intent of this diagram is to indicate that, if  $M$  is started in state  $q_0$  with input  $(w_M, w)$ , it will eventually halt in state  $q_y$  or  $q_n$ . As required by Definition 12.1, we want  $H$  to operate according to the following rules:

$$q_0 w_M w \vdash^*_{H} x_1 q_y x_2,$$

if  $M$  applied to  $w$  halts, and

$$q_0 w_M w \vdash^*_{H} y_1 q_n y_2,$$

if  $M$  applied to  $w$  does not halt.

**Figure 12.1**

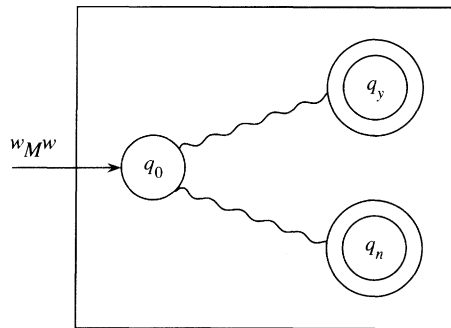
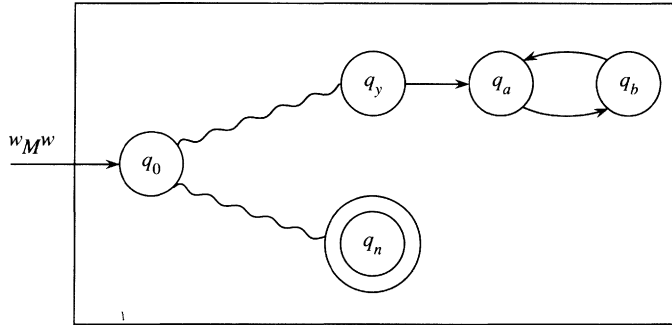

Figure 12.2



Next, we modify  $H$  to produce a Turing machine  $H'$  with the structure shown in Figure 12.2. With the added states in Figure 12.2 we want to convey that the transitions between state  $q_y$  and the new states  $q_a$  and  $q_b$  are to be made, regardless of the tape symbol, in such a way that the tape remains unchanged. The way this is done is straightforward. Comparing  $H$  and  $H'$  we see that, in situations where  $H$  reaches  $q_y$  and halts, the modified machine  $H'$  will enter an infinite loop. Formally, the action of  $H'$  is described by

$$q_0 w_M w \vdash_{H'}^* \infty,$$

if  $M$  applied to  $w$  halts, and

$$q_0 w_M w \vdash_{H'}^* y_1 q_n y_2,$$

if  $M$  applied to  $w$  does not halt.

From  $H'$  we construct another Turing machine  $\hat{H}$ . This new machine takes as input  $w_M$ , copies it, and then behaves exactly like  $H'$ . Then the action of  $\hat{H}$  is such that

$$q_0 w_M \vdash_{\hat{H}}^* q_0 w_M w_M \vdash_{\hat{H}}^* \infty,$$

if  $M$  applied to  $w_M$  halts, and

$$q_0 w_M \vdash_{\hat{H}}^* q_0 w_M w_M \vdash_{\hat{H}}^* y_1 q_n y_2,$$

if  $M$  applied to  $w_M$  does not halt.

Now  $\hat{H}$  is a Turing machine, so that it will have some description in  $\Sigma^*$ , say  $\hat{w}$ . This string, in addition to being the description of  $\hat{H}$  can also be used as input string. We can therefore legitimately ask what would happen if  $\hat{H}$  is applied to  $\hat{w}$ . From the above, identifying  $M$  with  $\hat{H}$ , we get

$$q_0\hat{w} \vdash^*_{\hat{H}} \infty,$$

if  $\hat{H}$  applied to  $\hat{w}$  halts, and

$$q_0\hat{w} \vdash^*_{\hat{H}} y_1q_ny_2,$$

if  $\hat{H}$  applied to  $\hat{w}$  does not halt. This is clearly nonsense. The contradiction tells us that our assumption of the existence of  $H$ , and hence the assumption of the decidability of the halting problem, must be false. ■

The standard pseudo-code halting problem template "proved" that the halting problem could never be solved on the basis that neither value of true (halting) nor false (not halting) could be correctly returned to the confounding input.

This problem is overcome on the basis that the halt decider aborts its simulation of this input before ever returning any value to this input. It aborts the simulation of its input on the basis that its input specifies what is essentially infinite recursion to any simulating halt decider.

```
procedure compute_g(i):
  if f(i, i) == 0 then
    return 0
  else
    loop forever // (Wikipedia:Halting Problem)
```

When halting is defined as any computation that halts without ever having its simulation aborted then it can be understood that partial halt decider  $H$  correctly decides that its input does not halt on the simplified version of the Linz  $\hat{H}$ .

The x86utm operating system was created so that the halting problem could be examined concretely in the high level language of C. UTM tape elements are 32-bit unsigned integers.  $H$  examines the behavior of the x86 emulation of its input. As soon as a non-halting behavior pattern is matched  $H$  aborts the simulation of its input and decides that its input does not halt.

A simulating halt decider  $H$  is a Universal Turing Machine (UTM) that has been adapted to decide whether or not its input halts.  $H$  simulates the execution of its inputs exactly as if it was simply a UTM. After  $H$  simulates each instruction of its input it examines the full execution trace of this input. When an execution trace matches an infinite execution behavior pattern  $H$  aborts the simulation of this input and reports that this input does not halt.

### **This halt deciding principle overcomes the conventional halting problem proofs:**

Every computation that never halts unless its simulation is aborted by its simulating halt decider is correctly decided as a computation that never halts.

```
// Simplified Linz  $\hat{H}$  (Linz:1990:319)
void H_Hat(u32 P)
{
  u32 Input_Halts = H(P, P);
  if (Input_Halts)
    HERE: goto HERE;
}

int main()
{
  H_Hat((u32)H_Hat, (u32)H_Hat);
}
```

```

_Hat()
[0000b10] (01) 55          push ebp
[0000b11] (02) 8bec         mov ebp,esp
[0000b13] (01) 51          push ecx
[0000b14] (03) 8b4508      mov eax,[ebp+08]
[0000b17] (01) 50          push eax
[0000b18] (03) 8b4d08      mov ecx,[ebp+08]
[0000b1b] (01) 51          push ecx
[0000b1c] (05) e81ffeffff  call 00000940
[0000b21] (03) 83c408      add esp,+08
[0000b24] (03) 8945fc      mov [ebp-04],eax
[0000b27] (04) 837dfc00   cmp dword [ebp-04],+00
[0000b2b] (02) 7402          jz 0000b2f
[0000b2d] (02) ebfe          jmp 0000b2d
[0000b2f] (02) 8be5          mov esp,ebp
[0000b31] (01) 5d          pop ebp
[0000b32] (01) c3          ret
Size in bytes:(0035) [0000b32]

```

```

_main()
[0000b40] (01) 55          push ebp
[0000b41] (02) 8bec         mov ebp,esp
[0000b43] (01) 51          push ecx
[0000b44] (05) 68100b0000  push 0000b10
[0000b49] (05) 68100b0000  push 0000b10
[0000b4e] (05) e8edfdffff  call 00000940
[0000b53] (03) 83c408      add esp,+08
[0000b56] (03) 8945fc      mov [ebp-04],eax
[0000b59] (03) 8b45fc      mov eax,[ebp-04]
[0000b5c] (01) 50          push eax
[0000b5d] (05) 682b030000  push 0000032b
[0000b62] (05) e8f9f7ffff  call 00000360
[0000b67] (03) 83c408      add esp,+08
[0000b6a] (02) 33c0          xor eax,eax
[0000b6c] (02) 8be5          mov esp,ebp
[0000b6e] (01) 5d          pop ebp
[0000b6f] (01) c3          ret
Size in bytes:(0048) [0000b6f]

```

### Columns

- (1) Machine address of instruction
- (2) Machine address of top of stack
- (3) Value of top of stack after instruction executed
- (4) Number of bytes of machine code
- (5) Machine language bytes
- (6) Assembly language text

```

=====
... [0000b40] [00101533] [00000000] (01) 55          push ebp
... [0000b41] [00101533] [00000000] (02) 8bec         mov ebp,esp
... [0000b43] [0010152f] [00000000] (01) 51          push ecx
... [0000b44] [0010152b] [0000b10] (05) 68100b0000  push 0000b10
... [0000b49] [00101527] [0000b10] (05) 68100b0000  push 0000b10
... [0000b4e] [00101523] [0000b53] (05) e8edfdffff  call 00000940
Begin Local Halt Decider Simulation at Machine Address:b10
... [0000b10] [002115d3] [002115d7] (01) 55          push ebp
... [0000b11] [002115d3] [002115d7] (02) 8bec         mov ebp,esp
... [0000b13] [002115cf] [002015a3] (01) 51          push ecx
... [0000b14] [002115cf] [002015a3] (03) 8b4508      mov eax,[ebp+08]
... [0000b17] [002115cb] [0000b10] (01) 50          push eax
... [0000b18] [002115cb] [0000b10] (03) 8b4d08      mov ecx,[ebp+08]
... [0000b1b] [002115c7] [0000b10] (01) 51          push ecx
... [0000b1c] [002115c3] [0000b21] (05) e81ffeffff  call 00000940
... [0000b10] [0025bffb] [0025bfff] (01) 55          push ebp
... [0000b11] [0025bffb] [0025bfff] (02) 8bec         mov ebp,esp
... [0000b13] [0025bfff] [0024bfc] (01) 51          push ecx

```

```

... [00000b14] [0025bff7] [0024bfc] (03) 8b4508 mov eax,[ebp+08]
... [00000b17] [0025bff3] [00000b10] (01) 50 push eax
... [00000b18] [0025bff3] [00000b10] (03) 8b4d08 mov ecx,[ebp+08]
... [00000b1b] [0025bfe] [00000b10] (01) 51 push ecx
... [00000b1c] [0025bfeb] [00000b21] (05) e81ffeffff call 00000940
Local Halt Decider: Infinite Recursion Detected Simulation Stopped
... [00000b53] [0010152f] [00000000] (03) 83c408 add esp,+08
... [00000b56] [0010152f] [00000000] (03) 8945fc mov [ebp-04],eax
... [00000b59] [0010152f] [00000000] (03) 8b45fc mov eax,[ebp-04]
... [00000b5c] [0010152b] [00000000] (01) 50 push eax
... [00000b5d] [00101527] [0000032b] (05) 682b030000 push 0000032b
--- [00000b62] [00101527] [0000032b] (05) e8f9f7ffff call 00000360
Input_would_Halt6 = 0
... [00000b67] [0010152f] [00000000] (03) 83c408 add esp,+08
... [00000b6a] [0010152f] [00000000] (02) 33c0 xor eax,eax
... [00000b6c] [00101533] [00000000] (02) 8be5 mov esp,ebp
... [00000b6e] [00101537] [00100000] (01) 5d pop ebp
... [00000b6f] [0010153b] [00000080] (01) c3 ret
Number_of_User_Instructions(33)
Number of Instructions Executed(26452)

```

When a chain of function calls specifies infinite recursion is broken by a simulating halt decider aborting the simulation of any one of these function calls, then the whole chain of function calls is correctly decided to specify a computation that does not halt.

This same reasoning applies to the computation:  $H_{\text{Hat}}((u32)H_{\text{Hat}})$ ; when  $H_{\text{Hat}}()$  invokes  $H()$  with its own machine address, this is the first invocation of an infinite chain of invocations. As the first element of an infinite chain of invocations where the third element of this chain is aborted the whole chain is understood to specify an infinite invocation sequence.

```

void H_Hat(u32 P)
{
    u32 Input_Halts = H(P, P);
    if (Input_Halts)
        HERE: goto HERE;
}

```

```

int main()
{
    H_Hat((u32)H_Hat);
}

```

```

_H_Hat()
[00000af8] (01) 55 push ebp
[00000af9] (02) 8bec mov ebp,esp
[00000afb] (01) 51 push ecx
[00000afc] (03) 8b4508 mov eax,[ebp+08]
[00000aff] (01) 50 push eax
[00000b00] (03) 8b4d08 mov ecx,[ebp+08]
[00000b03] (01) 51 push ecx
[00000b04] (05) e81ffeffff call 00000928
[00000b09] (03) 83c408 add esp,+08
[00000b0c] (03) 8945fc mov [ebp-04],eax
[00000b0f] (04) 837dfc00 cmp dword [ebp-04],+00
[00000b13] (02) 7402 jz 00000b17
[00000b15] (02) ebfe jmp 00000b15
[00000b17] (02) 8be5 mov esp,ebp
[00000b19] (01) 5d pop ebp
[00000b1a] (01) c3 ret
Size in bytes:(0035) [00000b1a]

```

```

main()
[0000b28] (01) 55          push ebp
[0000b29] (02) 8bec         mov ebp,esp
[0000b2b] (05) 68f80a0000 push 0000af8
[0000b30] (05) e8c3ffffff  call 0000af8
[0000b35] (03) 83c404     add esp,+04
[0000b38] (02) 33c0      xor eax,eax
[0000b3a] (01) 5d         pop ebp
[0000b3b] (01) c3         ret
Size in bytes:(0020) [0000b3b]

```

### Columns

- (1) Machine address of instruction
- (2) Machine address of top of stack
- (3) Value of top of stack after instruction executed
- (4) Number of bytes of machine code
- (5) Machine language bytes
- (6) Assembly language text

```

=====
... [0000b28] [001014cf] [00000000] (01) 55          push ebp
... [0000b29] [001014cf] [00000000] (02) 8bec         mov ebp,esp
... [0000b2b] [001014cb] [00000af8] (05) 68f80a0000 push 0000af8
... [0000b30] [001014c7] [00000b35] (05) e8c3ffffff  call 0000af8
... [0000af8] [001014c3] [001014cf] (01) 55          push ebp
... [0000af9] [001014c3] [001014cf] (02) 8bec         mov ebp,esp
... [0000afb] [001014bf] [00000000] (01) 51          push ecx
... [0000afc] [001014bf] [00000000] (03) 8b4508     mov eax,[ebp+08]
... [0000aff] [001014bb] [00000af8] (01) 50          push eax
... [0000b00] [001014bb] [00000af8] (03) 8b4d08     mov ecx,[ebp+08]
... [0000b03] [001014b7] [00000af8] (01) 51          push ecx
... [0000b04] [001014b3] [00000b09] (05) e81ffeffff  call 0000928
Begin Local Halt Decider Simulation at Machine Address:af8
... [0000af8] [0021156f] [00211573] (01) 55          push ebp
... [0000af9] [0021156f] [00211573] (02) 8bec         mov ebp,esp
... [0000afb] [0021156b] [0020153f] (01) 51          push ecx
... [0000afc] [0021156b] [0020153f] (03) 8b4508     mov eax,[ebp+08]
... [0000aff] [00211567] [00000af8] (01) 50          push eax
... [0000b00] [00211567] [00000af8] (03) 8b4d08     mov ecx,[ebp+08]
... [0000b03] [00211563] [00000af8] (01) 51          push ecx
... [0000b04] [0021155f] [00000b09] (05) e81ffeffff  call 0000928
... [0000af8] [0025bf97] [0025bf9b] (01) 55          push ebp
... [0000af9] [0025bf97] [0025bf9b] (02) 8bec         mov ebp,esp
... [0000afb] [0025bf93] [0024bf67] (01) 51          push ecx
... [0000afc] [0025bf93] [0024bf67] (03) 8b4508     mov eax,[ebp+08]
... [0000aff] [0025bf8f] [00000af8] (01) 50          push eax
... [0000b00] [0025bf8f] [00000af8] (03) 8b4d08     mov ecx,[ebp+08]
... [0000b03] [0025bf8b] [00000af8] (01) 51          push ecx
... [0000b04] [0025bf87] [00000b09] (05) e81ffeffff  call 0000928
Local Halt Decider: Infinite Recursion Detected Simulation Stopped
... [0000b09] [001014bf] [00000000] (03) 83c408     add esp,+08
... [0000b0c] [001014bf] [00000000] (03) 8945fc     mov [ebp-04],eax
... [0000b0f] [001014bf] [00000000] (04) 837dfc00  cmp dword [ebp-04],+00
... [0000b13] [001014bf] [00000000] (02) 7402      jz 0000b17
... [0000b17] [001014c3] [001014cf] (02) 8be5      mov esp,ebp
... [0000b19] [001014c7] [00000b35] (01) 5d         pop ebp
... [0000b1a] [001014cb] [00000af8] (01) c3         ret
... [0000b35] [001014cf] [00000000] (03) 83c404     add esp,+04
... [0000b38] [001014cf] [00000000] (02) 33c0      xor eax,eax
... [0000b3a] [001014d3] [00100000] (01) 5d         pop ebp
... [0000b3b] [001014d7] [00000098] (01) c3         ret
Number_of_User_Instructions(39)
Number of Instructions Executed(26459)

```